

A comparison of control concepts for wind turbines in terms of energy capture

(Vergleich von Regelungskonzepten für Windturbinen
auf der Grundlage ihres Energieertrages)

Vom Fachbereich 18
– Elektrotechnik und Informationstechnik –
der Technischen Universität Darmstadt
zur Erlangung der Würde eines Doktor-Ingenieurs
(Dr.-Ing.)

genehmigte
Dissertation

vorgelegt von
Dipl.-Ing. Rolf Hoffmann
geboren am 31. Juli 1970 in Darmstadt

Referent: Prof. Dr.-Ing. P. Mutschler
Korreferent: Prof. Dr.-Ing. T. Hartkopf

Tag der Einreichung: 8. Februar 2001
Tag der mündlichen Prüfung: 14. Januar 2002

D 17
Darmstädter Dissertation

Darmstadt 2002

Preface

This thesis was created during my work at the Institute for Power Electronics and Control of Drives of Darmstadt University of Technology. For all those who do not only want to know what I did, but also why I did it, I will in short tell the story why I wrote my thesis about this subject.

When I started my work here it was planned that I would work on power converter concepts for variable speed wind turbines and their control strategies. As a comparison between several power converter concepts for stall controlled variable speed machines was one of the topics, I started by creating a simulation model of a wind turbine and developed the wind speed observer, which is mentioned later in the text. When this work was done, the project was canceled.

Roughly at the same time I was asked to make a presentation regarding the control of wind turbines. But before the date of this presentation arrived, I went to the Risø National Laboratory in Denmark for two and a half months, as I had got a scholarship from the “Energietechnische Gesellschaft im VDE”. In Denmark I participated in the evaluation of data from a comparison between two-speed and variable speed operation of a wind turbine. To my surprise, the power curve for variable speed operation lay below the one for constant speed operation. This turned my attention towards energy capture.

When I had returned, I tried to incorporate the differences in terms of energy capture in the presentation, but when trying to find figures in the literature I stumbled over the big differences mentioned in the introduction. Therefore, I started to make my own thoughts about the subject and began with my first crude simulations, as my program was easily adaptable to this subject. At this time I recognized the strong influence of some parameters and became more and more curious. However, I didn't have the necessary time as the presentation had to be held soon.

Afterwards, I began to look at the subject more systematically. As I realized that a large number of simulations would be necessary, I automated a lot of the mechanical simulation work and started with the studies which are described in this thesis.

This story is the reason why I left my initial subject and did this rather basic study (which has an only loose connection with power electronics) at this institute.

Acknowledgements

Even if it should be unusual, I do not want to mention single persons as well as groups of people here and say what they specifically contributed to this work. The reason is that the people who helped me know best what they did for me, while on the other hand readers who do not know them cannot really appreciate the importance of all the support which made it possible for me to carry on with this project.

Instead, I simply say thank you to all of you who made this thesis possible and encouraged me to continue until everything is finished. Also thank you to all those people whose thoughts, ideas and opposition made me the person which I am now. Without all of you, I wouldn't have arrived here!

You can be sure that I will not forget your contributions and support, be it material or non-material, be it time, patience or just an open ear and be it before or during this work. And I will not stop by saying thank you; rather I hope that I will be able to support you when you might need it.

Contents

1	Introduction	1
1.1	History	1
1.2	Delimitation of scope	2
1.3	State of the art	2
1.4	Approach	4
2	Description of the wind turbine concepts	6
2.1	The stall controlled single speed concept	9
2.2	The stall controlled two speed concept	11
2.3	The active stall controlled single speed concept	12
2.4	The active stall controlled two speed concept	13
2.5	The pitch controlled single speed concept	13
2.6	The pitch controlled two speed concept	14
2.7	The stall controlled variable speed concept	15
2.8	The pitch controlled variable speed concept	16
3	Control concepts	18
3.1	Control for constant speed concepts	19
3.1.1	The stall controlled concepts	21
3.1.2	The active stall controlled concepts	21
3.1.3	The pitch controlled concepts	25
3.2	Control for variable speed concepts	26
3.2.1	The stall controlled concept	27
3.2.2	The pitch controlled concept	31
4	Modeling the wind turbine	37
4.1	Wind flow	38
4.2	Wind turbine rotor	46
4.3	Gearbox	53
4.4	Generator	53
4.5	Power converter	53
4.6	Transformer	54
4.7	Controller	54
4.8	Losses	54
4.9	Calibration	56
4.10	Calculation of the annual energy capture	57
5	Simulation results in the time domain	61
5.1	Operation at partial load	61
5.2	Operation near rated wind speed	66
5.3	Operation in power limiting	74

6	Simulation results in terms of energy capture	79
6.1	Power curves	79
6.2	Influence of the annual mean wind speed	85
6.3	Influence of the annual wind speed distribution	88
6.4	Influence of the turbulence	96
6.5	Influence of the design tip speed ratio	100
6.6	Influence of the aerodynamic rotor profile	104
7	Conclusion	110
8	Outlook	111
9	Appendix	112
9.1	Derivation of the polynomial coefficients of table 8	112
9.2	Parameters of the wind turbine model	115
9.3	Block diagrams of simulated systems	116
10	References	130

Table of symbols

Important notice: All quantities are measured in SI units if not mentioned otherwise!

Main symbols

A	Area
C	Constant (general purpose, explained where used)
D	Aerodynamic drag
E	Annual energy capture of the wind turbine
F	Transfer function
Fl	Flag
I	Current
K	Gain factor of controller
L	Aerodynamic lift
P	Power
R	Random number (from random number generator)
T	Torque
WPG	Wind power gradient
a	Weibull distribution scale parameter
c	Coefficient
f	Factor (general purpose, explained where used)
h	Frequency density
i	Integer counter variable
j	Integer counter variable
k	Weibull distribution shape parameter
n	Rotational speed in rpm
m	Integer number
p	Probability
r	Radius
s	Laplace operator
t	Time
v	Speed (linear)
Θ	Inertia
Ω	Rotational speed
α	Pitch angle of the rotor blades
β	Angle of attack
λ	Tip speed ratio, $\lambda = \frac{v_T}{v_w}$
γ	Angle (general purpose)
ρ	Air density

Indices

C	Controller
D	Design value
G	Generator

L	Loss
O	Open loop
P	Power
$Rayl$	Rayleigh
R	Rotor
T	Tip, measured at the tips
$Turb$	Turbulence
W	Closed loop
$Weib$	Weibull
WPG	Wind power gradient
a	Annual
d	Drag
g	Grid
i	Integral (part of controller)
j	Counting index
l	Lift
n	Numbered interval
obs	Observed
opt	Optimum
p	Proportional (part of controller)
r	Rated
$switch$	limit value for switching actions
v	Speed
w	Wind
$year$	Related to one year
Ω	Rotational speed

Superscripts

*	Reference value
-	Mean value
'	Transformed (it does <i>not</i> mean derivative!)

Prefixes

Δ	Difference
----------	------------

Quantities

A_R	Rotor area (area swept by the blades), $A_R = \pi r_R^2$
$C_{n,2}$	Polynomial coefficient for wind speed calculation in time interval n
$C_{n,3}$	Polynomial coefficient for wind speed calculation in time interval n
E_v	Energy captured in one wind speed interval
F_C	Transfer function of the controller

F_O	Open loop transfer function of the control loop
F_W	Closed loop transfer function of the control loop
K_{iP}	Integral gain factor of the power controller
K_{pP}	Proportional gain factor of the power controller
$K_{p\Omega}$	Proportional gain factor of the speed controller
P_G	Input (mechanical) power of the generator
P_g	Instantaneous power fed to the grid
\overline{P}_g	Average power fed to the grid
P_G^*	Reference input (mechanical) power of the generator
P_{Gr}	Rated input (mechanical) power of the generator
P_L	Power loss
P_R	Rotor power
$P_{R,obs}$	Observed rotor power
P_r	Rated power
P_w	Power inherent in the wind
$R_{v,n}$	Random number for wind speed generation in the n -th time interval
$R_{WPG,n}$	Random number for wind power gradient generation in the n -th time interval
T_G	Generator torque
T_G^*	Reference torque of the generator
T_R	Rotor torque
$T_{R,obs}$	Observed rotor torque
\overline{WPG}	Average wind power gradient
WPG_n	Wind power gradient during interval n
$\overline{WPG}(\overline{v}_w)$	Average wind power gradient at average wind speed \overline{v}_w
c_d	Drag coefficient
c_l	Lift coefficient
c_P	Power coefficient
$c_{P,opt}$	Maximum power coefficient for the actual rotor
c_{Turb}	Turbulence intensity (measured in%)
c_{WPG}	Coefficient for the calculation of the average wind power gradient
$\frac{d\alpha}{dt}$	Slope of pitch angle α
$\left. \frac{dv_w}{dt} \right _n$	Slope of wind speed during time interval n
h_{Rayl}	Frequency density of the Rayleigh distribution
h_{Weib}	Frequency density of the Weibull distribution
n_r	Rated rotational speed
r_R	Rotor radius
$t(\overline{v}_w)$	Time in one year during which the average wind speed is \overline{v}_w
t_n	End of time interval n
t_{n-1}	Beginning of time interval n (= end of time interval $n - 1$)
t_{obs}	Time constant of the torque observer (variable speed stall controlled system)
t_{year}	Duration of one year (i.e. 8760h)
v_T	Velocity at the tips of the rotor blades
v_w	Wind speed
\overline{v}_w	Average wind speed (e.g. of one simulation)
$\overline{v}_{w,a}$	Annual mean wind speed (of the site)

$\bar{v}_{w,i}$	i -th average wind speed
$v_{w,n}$	Wind speed at the end of interval n
$v_{w,n-1}$	Wind speed at the beginning of interval n (= end of time interval $n - 1$)
$\bar{v}_{w,switch}$	average wind speed limit (two speed concepts are in low speed mode below)
$\bar{v}_{w,switch}$	"measured" average wind speed in wind speed generation
ΔE	Energy gain of the different concepts under comparison over concept 1
ΔP_G	Deviation of the generator power
Δt_n	Duration of time interval n
Δv_w	Width of wind speed interval
Θ_R	Rotor inertia (with generator inertia included)
Ω_R	Rotational speed of the rotor
Ω_R^*	Reference rotational speed
Ω_{Ri}^*	Output of the integral part of the power controller
$\Omega_{R,obs}$	Observed rotational speed of the rotor
Ω_{Rr}	Rated rotational speed of the rotor (where rated power is reached)
α_{opt}	Optimum pitch angle (giving maximum power)
γ_r	Rotor angle
λ_D	Design tip speed ratio
λ_{opt}	Optimum tip speed ratio (giving maximum power coefficient)

Abstract

In this study, eight different control concepts for wind turbines are compared in terms of their annual energy capture. In detail, they are a stall controlled single speed concept, a stall controlled two speed concept, an active stall controlled single speed concept, an active stall controlled two speed concept, a pitch controlled single speed concept, a pitch controlled two speed concept, a stall controlled variable speed concept and finally a pitch controlled variable speed concept.

In order to be able to expose all these different concepts to exactly the same wind conditions, numerical computer simulation is chosen as the appropriate method to do the comparison, as in reality it is almost impossible to achieve the same wind conditions for different turbines. This approach also prevents all possible differences in rotor layout between the individual concepts from entering into the results, as it is possible to use the same rotor design for all control concepts. Because the influence of time variant quantities such as the turbulent wind flow on a nonlinear system (e.g. a wind turbine rotor) has to be taken into account, an analytical representation had to be found which allowed a time-step simulation. This especially set some limits on the complexity allowed for the numerical model. Therefore the modeling of all parts of the system (whether they are aerodynamic, mechanic or electric) is kept rather simplistic.

As a comparison of general control concepts is the topic of this study, the controllers are not modeled as they are used by a certain manufacturer. Instead they are modeled in an idealized way, each of which covers the ideal performance of one class of control concepts.

For each combination of parameters, one time domain simulation was performed. The output data was then weighted and averaged in order to obtain the energy captured from the wind within one year. These energy values are finally arranged in a way which allows an easy comparison between the relative performance of all control concepts under consideration.

The results show the differences in the annual energy capture of the eight concepts as a function of site conditions (the annual mean wind speed, the turbulence and the shape parameter of the Weibull distribution assumed for the annual wind speed distribution) as well as their dependence on two design parameters (the design tip speed ratio and the choice of rotor profiles). Due to the rather crude modeling these results have to be seen more qualitatively than quantitatively. However, they show to which extent a comparison between different control concepts depends on the values of different parameters. Hopefully, they also lead to a deeper understanding of the very different results of similar comparisons found in the literature.

Deutsche Zusammenfassung

In dieser Arbeit werden acht verschiedene Regelverfahren für Windkraftanlagen in Bezug auf ihren Jahresenergieertrag verglichen. Im einzelnen handelt es sich um die folgenden Konzepte: ein stallgeregeltes drehzahlstarres Konzept, ein stallgeregeltes Konzept mit zwei Drehzahlen, ein aktiv-stallgeregeltes drehzahlstarres Konzept, ein aktiv-stallgeregeltes Konzept mit zwei Drehzahlen, ein pitchgeregeltes drehzahlstarres Konzept, ein pitchgeregeltes Konzept mit zwei Drehzahlen, ein stallgeregeltes drehzahlvariables Konzept und schließlich ein pitchgeregeltes drehzahlvariables Konzept.

Um alle diese Konzepte unter exakt den gleichen Windbedingungen zu untersuchen, wurde eine numerische Simulation auf einem Digitalrechner entwickelt, da es bei Messungen nahezu unmöglich ist, für verschiedene Windturbinen die gleichen Umgebungsbedingungen zu gewährleisten. Gleichzeitig verhindert dieses Vorgehen, daß Unterschiede in der Rotorauslegung der verschiedenen Konzepte in die Ergebnisse eingehen, da ein und derselbe Rotor für alle Regelverfahren verwendet wird. Da der Einfluß von zeitveränderlichen Größen wie der Windgeschwindigkeit auf ein nichtlineares System (wie z.B. den Rotor der Windkraftanlage) untersucht werden soll, wurde eine mathematische Modellbildung gewählt, die eine Zeitschrittsimulation erlaubt. Daraus folgten insbesondere einige Beschränkungen für den Rechenzeitbedarf des mathematischen Modells. Daher mußte die Beschreibung aller Systembestandteile – seien sie nun aerodynamisch, mechanisch oder elektrisch – in relativ einfachen Modellen erfolgen.

Da der Hauptzweck der Arbeit der Vergleich von Regelungskonzepten ist, sind die Reglermodelle nicht den Reglern einzelner Hersteller detailliert nachgebildet. Stattdessen sind sie so gewählt, daß sie jeweils eine ganze Klasse von Verfahren mit ihren idealtypischen Eigenschaften repräsentieren.

Für jede Kombination von Parametern wurde eine Simulation durchgeführt, aus deren Ergebnissen durch gewichtete Mittelwertbildung die in einem Jahr aus dem Wind geerntete Energie berechnet wurde. Die so erhaltenen Energieerträge werden auf eine Art dargestellt, die einen einfachen Vergleich zwischen den verschiedenen Konzepten gewährleistet.

Die Ergebnisse zeigen die Unterschiede der acht Konzepte im Jahresenergieertrag in Abhängigkeit von Standortparametern (dem Jahresmittelwert der Windgeschwindigkeit, der Turbulenz und dem Formparameter der für die Jahreswindgeschwindigkeitsverteilung angenommenen Weibullverteilung) und von Auslegungsparametern der Turbine (der Auslegungsschnellaufzahl des Rotors und dem Rotorblattprofil). Wegen der relativ einfachen Modellbildung sind diese Ergebnisse zwar eher qualitativ als quantitativ zu sehen, aber sie zeigen, in welchem hohem Maße ein Vergleich von Energieerträgen von den Werten der einzelnen Parameter abhängt. Eventuell führen sie auch zu einer besseren Einordnung der sehr verschiedenen in der Literatur veröffentlichten Ergebnisse solcher Vergleiche.

1 Introduction

1.1 History

Wind energy was used successfully for several hundreds of years by windmills before the industrial revolution led to the use of thermal power. The availability of electrical energy made the classical uses of wind energy (corn grinding and water pumping) unattractive, because wind energy is by far not as reliably available as electrical power (at least in the developed countries). Although the Danish pioneer Poul la Cour showed at the end of the 19th century that wind energy could be used for generation of electricity, later on the low oil and coal prices made this option economically unattractive [37, 30].

Despite several efforts from the 1930s to the 1950s (see [31] for details), it was not until the first oil price crisis in 1973 that the development of modern wind turbines started on a larger scale. Unfortunately, the “large scale” was at first mainly seen as the size of the single wind turbine, which led to the development of huge machines as research prototypes. Most of these huge turbines suffered not only from technical problems, but they were much too expensive, too [15, 32]. So it showed up that it was a better idea to start with small turbines of only several tens of kilowatts [33]. These small machines could produce the energy much cheaper than the large ones, and due to their lower cost they could also be purchased by private persons which became interested in wind energy because of tax advantages or later also because of subsidies [15].

Because these wind turbines were small and had to be cheap, the control of the turbines was reduced to the inevitable minimum. As most of these early commercial turbines were produced in Denmark [29], the control concept used for them was called the “Danish concept”. In its simplest way, it can be described as a turbine with three rotor blades operating at a constant speed. This allows the use of an asynchronous generator. The rotor blades are fixed (they cannot be turned around their axes) and the necessary power limitation during storms is achieved by the stall effect¹.

Together with the development of the wind industry, a technical development began which aimed at larger turbines. The knowledge gained with each power class of wind turbines helped to develop the next bigger class. This process is called “upscaling”. It is so successful that today’s commercial wind turbines have reached the size of many of the research prototypes of the eighties [15, 14]. During this development, not only the mechanical components became more and more complex, but the electrical system and the turbine control evolved, too. Some manufacturers made the rotor blades of their turbines pivoted and use this degree of freedom to limit power during storms, but also to maximize the power output at lower wind speeds. Others used power electronics to make the rotational speed of the whole rotor variable. Some of them replaced the asynchronous generator by a synchronous one and were able to leave out the gearbox. So today, there are a large number of control concepts on the market.

¹See section 2 for a more detailed explanation and a definition of these terms.

1.2 Delimitation of scope

A comparison between control concepts can be done in many different ways, as each characteristic of a control concept can be looked at alone or in combination with other characteristics. The interesting properties can be divided into electrical, mechanical and economical ones. Among the electrical properties are at least the following: Reactive power consumption, active power quality (i.e. how smooth the time characteristic of the output power is), energy capture. The mechanical characteristics include loads, dynamics, oscillations and distortions. The economical properties comprise things like cost of manufacturing, complexity, reliability and ease of maintenance.

Altogether, these are quite a few characteristics. In addition, almost anybody would choose a different way of weighting them together to something like an overall quality factor. But even if representative weights could be found it would show up that every property depends on other parameters, so that the number of combinations would probably almost approach infinity and no precise deductions could be gained from such a comparison. Furthermore, one person cannot be an expert in all the different fields which are needed for sound results.

Therefore, this study concentrates on one single criterion, which is energy capture. With this concentration, it is possible to show the influence of many different parameters for many different control concepts.

Another limitation of this study is that only horizontal axis wind turbines are looked at. There are two reasons for this: The first one is that vertical axis wind turbines aren't much present in the marketplace, at least not for large turbines [14]. For small turbines a lot of vertical axis concepts are shown in [14], but they use many different and often exotic concepts, so that it will be difficult to establish a few representative concepts. The second reason for omitting them is that vertical axis wind turbines are much more difficult to model, and according to [37] the models are not very good due to a lack of knowledge in the dynamic stall area. As this was intended to become a comparative study, it was important that the models of all concepts are of a similar accuracy. Therefore, the vertical axis wind turbines had to be left out.

1.3 State of the art

A lot of work was and is used to compare different concepts for wind turbines. Besides many publications which focus on economical and mechanical properties, there are also quite a few focusing on electrical properties. With respect to the topic of this work, all those focusing entirely on flicker and power quality are not of big interest. So there remain the publications which also include results on energy capture. They generally compare only some of the possible concepts and, what is even more problematic, they come up with very different results for the same question. The best documented example is the comparison of variable speed against constant speed.

Here, [11] differentiates between four concepts, but in terms of energy capture it says that variable speed turbines will produce between 2% and 6% more energy than constant speed turbines, and it claims that the gain will be dependent on location. This can also be interpreted so that the energy gain is dependent on the wind conditions, which will also be supported by this study.

Reference [36] says that the energy capture of a constant speed stall design is 6.6% lower than for a variable speed stall controlled concept, while a variable speed pitch controlled concept will gain 1.6% more energy than the variable speed stall controlled concept. This comparison was made for a site with $8m/s$ annual mean wind speed.

Reference [51] gives detailed figures for the gain of one very narrow-band variable speed system (the Vestas OptiSlip concept) and one real variable speed system over a constant speed system. The results are given with the annual mean wind speed and the Weibull shape parameter as parameters, and for the real variable speed system the gain over the constant speed concepts lies between 5.29% and 9.36%. The latter is for the very low annual mean wind speed of $4.5m/s$. For a somewhat higher annual mean wind speed of $5.0m/s$ the maximum energy gain is 6.95%.

There are also other studies like [28], which doesn't compare the different control concepts, but discusses the influence of rotor profile variations on the energy yield.

It can be clearly seen from these figures that all these studies came to similar results, as the figures are very close together. So the need for a new study is not evident, as everything seems to be all right. But there are also studies which came to rather different results. For example, [26] claims that "the advantages of variable speed are well accepted" and "include an increase in energy output of up to 20%". This is much more than the previous papers reported, but that's still not as far as the values can go. Reference [53] does not give figures for the energy gain of variable speed directly, but it provides a figure giving the annual energy production of both concepts as a function of annual mean wind speed. If the values of energy production for variable speed are compared to those of constant speed, an energy gain is found which is between 30% and 40% for a wide range of annual mean wind speeds.

On the other hand, there is an experimental comparison published in [6, 5]. It was done by fitting an existing pitch controlled two speed wind turbine with a power converter. Then this wind turbine ran alternately some time in direct grid connected mode and in variable speed mode. In this way, the influence of different site conditions should be kept from entering the results, as the measurements for both modes of operation were done at the same place and close in time. Interestingly, this study came up with results which are completely different from the theoretical studies mentioned in the last paragraph. Reference [6] shows a power curve which indicates a lower produced power for variable speed operation than for constant speed operation between $6m/s$ and $9.5m/s$ wind speed. From the same investigation, [5] presents a power curve for variable speed operation which lies entirely below the power curve for constant speed operation. In [5], the authors come to the conclusion that this is a result from the losses of the variable speed concept, which are much higher than the losses in a constant speed concept. Interestingly, not the losses produced by the power converter itself make the big difference, but the losses of the asynchronous generator increase much when the power converter is used. This is probably due to the voltage harmonics originating from the switching actions of the power converter. However, the authors do not publish data in terms of annual energy capture, so no percentage of lower energy capture for the variable speed concept can be given here. But as the power curve for variable speed operation lies below the curve for constant speed operation, it is clear that under this specific conditions variable speed operation caused a loss in energy production.

From the very different values in these publications several questions arise: Where

do these large differences come from? And, if they come from differences in parameters, which parameters are important? In which direction must they be altered to increase or decrease the energy gain of a concept over another one? And finally, are there concepts which are more effected by a variation in these parameters than others?

To help in answering these questions is the main objective of this study. However, this study should be seen as a starting point and not as a solution. The methods used here are rather crude, so that they allow only a more qualitative than quantitative analysis. Therefore there remain large fields for future work.

1.4 Approach

In order to make a fair comparison between control concepts for wind turbines, it is very important that all concepts are tested under the same conditions. This is very difficult to achieve in practical measurements, as it is probably impossible to find two sites for wind turbines which have exactly the same wind conditions². One solution to this problem is shown in [6, 5], as was already mentioned above. But the method shown in this study cannot be extended to more different concepts, as for example with this method it is not possible to use two different generator concepts (like asynchronous and synchronous), or to compare a direct driven generator with a higher speed generator and a gearbox. So this setup cannot be used to compare the many very different concepts which should be compared in order to achieve a general overview.

The only way to have exactly the same wind input to all concepts is by creating it artificially. One way to do this is by using a wind tunnel, but this leads to very small models, as large wind tunnels are rare and expensive. In addition, it is rather difficult to create a specified turbulence level in a wind tunnel. Therefore, the only solution which remains for a broad and fair comparison is to model the concepts mathematically and use computer simulation techniques. This allows to create exactly the same conditions and parameters over and over again. Its drawback is the limited accuracy, which is not only due to the numerical accuracy of the calculations, but also to the problem that the equations are only a model which resembles reality more or less, but they are not reality.

So computer simulation was adopted as the appropriate method to compare the concepts. Another advantage of this method is that it is very easy to alter all interesting parameters. Therefore, a study of the influence of the different parameters could be made.

Because the task is to compare control concepts, the model has to be chosen in a way so that it represents the behaviour of the wind turbine properly. As wind turbines have partially a highly nonlinear behaviour, it is clear that the model must be able to represent this, which allows only a time domain model. On the other hand, the annual energy capture is not a time domain function. For these reasons, the simulation of the wind turbine together with the control system has to be a time domain (time step) simulation, while afterwards the simulation results have to be processed to calculate the annual energy capture.

²It is rather easy to achieve this if only the annual mean wind speed is of concern, but here also the wind speed distribution and the turbulence are important.

For a fair comparison, it is also important that all control concepts are tested (or better: simulated) on the same wind turbine layout, which means the same power class and rotor properties (diameter and aerodynamic profile). For this study, the best-selling power class of wind turbines was used, which was the $600kW$ -class at the time when this study was started. For the rotor diameter of such turbines $45m$ was found to be close to the average of the rotor diameters in use by such wind turbines, so this value was used.

The steps in this work are represented by the different sections of this thesis. First, *section 2* describes the general mechanical layout which follows from the different control concepts. *Section 3* gives a detailed description of the control concepts which were used for this study. *Section 4* describes the modeling of the mechanical and electrical components and the general setup of the simulation program. *Section 5* gives typical time characteristics of the power output of the different concepts. Although this is not the main topic of this study, the time characteristics should not be completely neglected. Finally, *section 6* presents the results in terms of energy capture for all the different concepts. The influence of the different parameters is also discussed in this section, and some power curves are shown to explain the behaviour of the different concepts.

2 Description of the wind turbine concepts

In this section, the general mechanical layout of all wind turbine concepts under consideration will be shown and described. Also, some general advantages and disadvantages of the individual concepts will be discussed here.

First, the question arises which general concepts for wind turbines are possible. While these concepts are not new and are mentioned for example in [15, 9], I will try to introduce them systematically here.

There are two independent main characteristics by which the control of wind turbines can be divided:

- The ability of the wind turbine to adapt its rotor speed during normal energy production operation³. The typical possibilities here are (see e.g. reference [4]):
 - One constant speed which is used whenever the wind turbine is connected to the grid. This will be called a *single speed concept*.
 - Two alternative rotor speeds which can be used according to the actual wind conditions. Typically the change between these two rotor speeds is a time consuming procedure, so that the speed cannot be changed for single wind gusts, but is rather chosen according to the average wind speed. This type will be called a *two speed concept*.
 - A continuously variable rotor speed, which is varied by a controller according to the actual wind speed or the output power of the wind turbine. The possible rotor speeds form a band which can range from narrow to wide⁴. This will be called a *variable speed concept*. The power is then transmitted via a power converter to the grid, as mentioned in [45].
- The method of limiting the power taken from the wind when the power available in the wind becomes higher than the power for which the wind turbine is designed (i.e. when the wind speed becomes higher than the rated wind speed). Here, there are three possibilities. For the first one, the rotor blades are mounted fix on the hub, while for the latter two the rotor blades need to be pivoted around their axis. In detail, the three possibilities are [34]:
 - The wind turbine uses the fact that the angle of attack grows with increasing wind speed in such a manner that the angle of attack where stall occurs is reached when the wind speed reaches rated wind speed. As mentioned before, the rotor blades are mounted fix on the hub. The rotor blades have then to be installed in the needed angle during the construction of the turbine.

This means that the wind turbine rests completely passive while the wind causes the power regulation by itself. Therefore, this concept will be called a *passive stall controlled concept* or short a *stall controlled concept*.

³This definition, which may seem strange at first glance, is required here because single speed turbines also run with a varying rotor speed during the startup and shutdown process.

⁴It is also possible that one or more narrow speed bands in the operational speed band are forbidden in order to avoid the excitation of mechanical eigenfrequencies

- It is also possible to turn the rotor blades around their axes to cause stall when it is needed. As this concept needs the wind turbine to actively do something, it will be called an *active stall controlled concept* in the following⁵.
- Finally, the rotor blades can also be turned in the opposite direction in order to reduce the angle of attack and thereby the aerodynamic forces and the power output. This concept will be called a *pitch controlled concept*⁶.

As these two main characteristics are completely independent, they can be combined in any way. This can be shown in a combination matrix, which is given in table 1. The fields in table 1 give the names by which the individual concepts will be identified throughout this work. The numbers given will be used in figures to identify the concepts or as a quick reference.

Table 1: The possible combinations of the two characteristics

	(passive) stall	active stall	pitch
single speed	stall controlled single speed concept 1	active stall controlled single speed concept 3	pitch controlled single speed concept 5
two speed	stall controlled two speed concept 2	active stall controlled two speed concept 4	pitch controlled two speed concept 6
variable speed	stall controlled variable speed concept 7	active stall controlled variable speed concept	pitch controlled variable speed concept 8

The active stall controlled variable speed concept doesn't have a number because it will not be taken into consideration any further. The reason for this is that variable speed operation allows to induce the stall effect by properly choosing the rotation speed of the rotor without having to pitch the blades. So the stall controlled, variable speed concept is also able to control the output power to the wanted level⁷. This means that the active stall controlled variable speed concept doesn't seem to have any advantages over the stall controlled variable speed concept, but it is definitely more complicated because it needs pitchable rotor blades. Therefore, it is also likely that it is more expensive. For this reason, this concept is left out here.

Until now, the concepts are rather abstract, as only their general behaviour has been addressed, but no thoughts were given to the realization. According to the typical realizations described in [15, 37, 14], some more detail will be added now.

⁵This concept is also known as *pitch to stall*

⁶It is also known as *pitch to feather*

⁷At least as a time average. See section 5 for details.

The concepts which use passive stall control have their rotor blades fixed to the hub. In contrast, all those concepts which can turn their rotor blades need some sort of actuators to turn them, because they have to be turned to the direction and angle which the control system requires even when the aerodynamic forces want to turn them in the opposite direction. These actuators can be either electric or hydraulic. Usually the actuators of the different rotor blades are as independent as possible, so that there is redundancy if one actuator fails. The pitch controlled concepts require much larger turn angles than the active stall controlled concepts to achieve a power decrease of the same amount. But the time available is determined by the wind conditions (e.g. the rise time of a wind gust) and therefore it is the same for both concepts. For this reason, the pitch controlled concepts need to turn the rotor blades much faster and therefore they need much stronger pitch actuators.

The single speed concepts can easily use an asynchronous generator which is connected directly to the grid. The same generator can be used for the two speed concepts with the only difference that it has to be a pole-changing multispeed generator. The big advantage of the asynchronous generator is that it provides enough electrical damping, so that torsional oscillations of the rotor of the wind turbine against the grid will not be a problem [20]. The disadvantage is that it is not possible to build asynchronous generators for the typical low speeds of wind turbines⁸ with a high power coefficient and a high efficiency. Therefore, the asynchronous generators need to be connected to the rotor of the wind turbine using a gearbox.

On the other hand, all the variable speed concepts need a power converter. It is of course possible to connect the power converter between an asynchronous generator and the grid (as it is described in the experimental setup in [6]), but in doing this the power converter has to handle the full power of the wind turbine and the expensive gearbox is still needed. So this layout doesn't seem to be attractive from an economic point of view. There are two possibilities of reducing the cost.

The first one is to use a double-fed induction generator with the frequency converter connected to the rotor winding. In this layout, the frequency converter does not handle the full power. Instead, only the stator power multiplied by the slip is transmitted via the power converter. The drawbacks of this concept are that the gearbox is still necessary and that the possible speed band is rather limited.

When this work was started, this system was not too popular among wind turbine manufacturers. Therefore, it was not chosen as the typical variable speed system for this study. However, in the meantime it became rather popular and it is now built by many wind turbine manufacturers.

The second possibility to reduce the overall cost uses the control possibilities offered by the power converter. The possibility of achieving any desired torque value very fast allows to create artificial damping even when using a synchronous generator. As the flux of the synchronous generator is not created by drawing reactive power from the grid, but by the excitation on the rotor, the synchronous generator can be designed to run at the operating speeds of the wind turbine. Therefore, a gearbox is not necessary in this layout.

The chosen general layouts for all concepts are given in table 2.

⁸Typically between 15rpm and 40rpm.

Table 2: General layouts of the concepts

Concept number	pitch actuators	power limiting	rotor speeds	gearbox	type of generator
1	none	stall	1	yes	asynchronous
2	none	stall	2	yes	asynchronous
3	low-powered	active stall	1	yes	asynchronous
4	low-powered	active stall	2	yes	asynchronous
5	powerful	pitch	1	yes	asynchronous
6	powerful	pitch	2	yes	asynchronous
7	none	stall	variable	no	synchronous
8	powerful	pitch	variable	no	synchronous

In the following, each of these concepts will be described in even more detail, together with a drawing of a typical mechanical layout and a short discussion of the general advantages and disadvantages. The stall controlled, single speed concept will be described in deeper detail, as it will be used as a reference for the other concepts. For them, the emphasis will be on the differences to this reference concept.

2.1 The stall controlled single speed concept

This concept is the simplest and oldest of the concepts on the market. It is also known as the "Danish concept". A typical mechanical layout of it is shown in figure 1.

The rotor is built with the blades fixed on the hub. Therefore, it is rather simple in construction. The angle of the blades is adjusted only once when the turbine is erected.

The weight of the rotor is carried by a strong bearing, which has to be dimensioned so that it is also able to absorb all aerodynamic forces, especially the rotor thrust.

A strong brake is needed for safety reasons. As the rotor blades are fixed, the aerodynamic input power of the wind turbine is solely a function of the wind speed and the rotational speed of the wind turbine rotor. The only parameter which can be used to control the turbine is the rotational speed, which is normally kept constant by the asynchronous generator. But the turbine must be safe under any circumstances, even during a grid failure when the energy cannot be fed into the grid. In such a situation, the turbine rotor must be stopped by the mechanical brake. To achieve this, the braking torque must be higher than the aerodynamic torque regardless of wind speed and the brake must be able to absorb the energy which is stored in the rotating masses as well as the energy which is taken from the wind during the braking process. As the failure of one single component should not endanger the turbine, the brake must also be able to work during a gearbox failure. Therefore, the brake must be mounted on the low speed shaft, which requires a high braking torque and therefore leads to a large, heavy and expensive brake. A second braking system for emergency cases is also required.

Another possibility is to make the tips of the rotor blades revolving, so that they

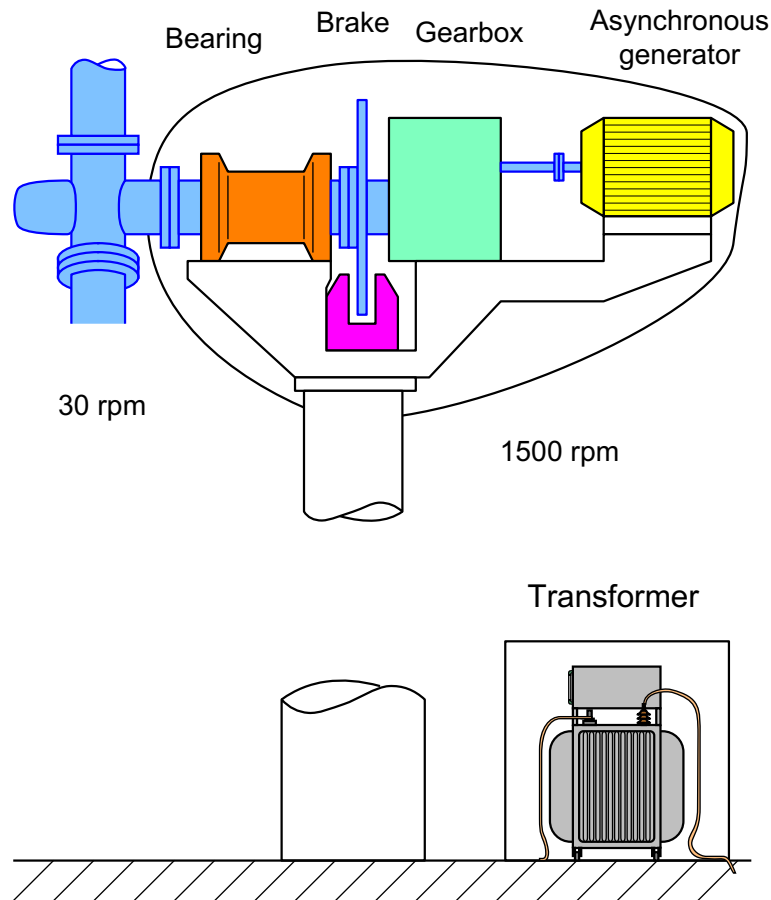

Figure 1: Typical mechanical layout of a stall controlled single speed wind turbine

can be used in an emergency case to brake down the rotor. The brake need then only be a parking brake, as described in section 2.3, because it is not relevant for safety. In this case, it can also be mounted on the high speed shaft, where the required torque is reduced by the transmission ratio of the gearbox. Therefore, the brake will be much lighter and cheaper.

The next step in the energy transmission chain is the gearbox, which translates the motion of the slow shaft to the fast shaft.

The gearbox is coupled to the generator, which should be of the asynchronous type to provide enough damping for the rotational oscillations of the rotor against the electrical grid (see reference [21] for details of the possible torsional modes).

Finally, a transformer is required to couple the usually low voltage generator to the medium voltage grid.

This concept is in general very simple and (if properly designed) rather robust, but it is not very flexible. For example, the rotor is optimum only at one wind speed value, while its efficiency is reduced at all other wind speeds.

2.2 The stall controlled two speed concept

One solution to overcome this problem is to introduce a second rotor speed which is used for low wind speeds and which increases the aerodynamic efficiency of the rotor for these conditions. A layout of this concept is shown in figure 2.

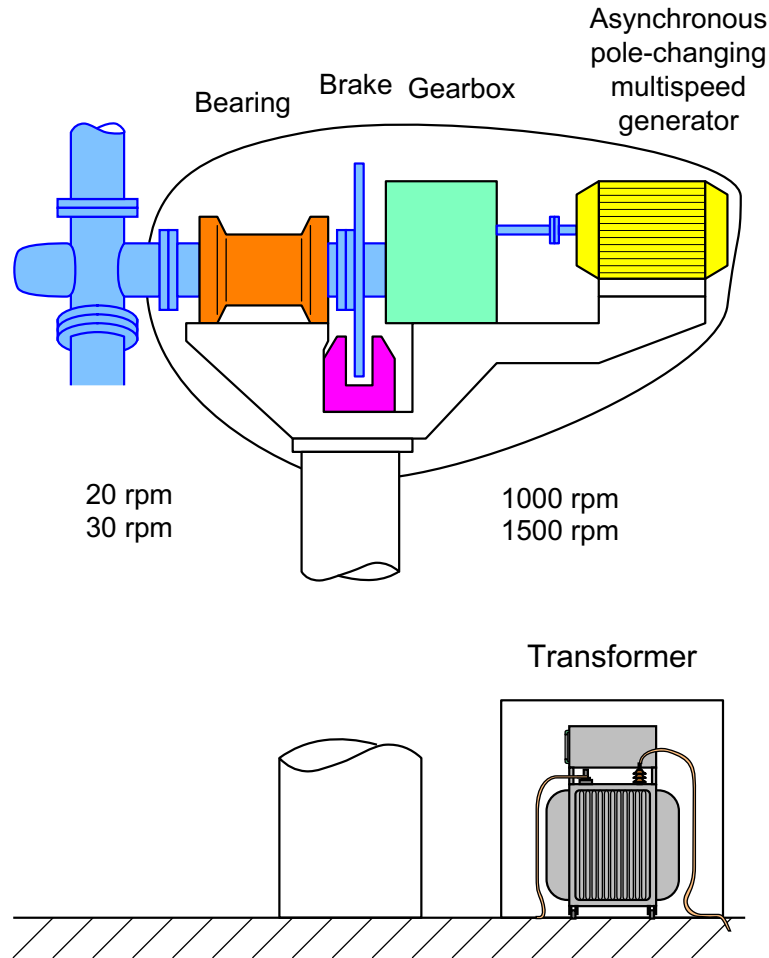

Figure 2: Typical mechanical layout of a stall controlled two speed wind turbine

The only difference of this concept when compared to figure 1 is that the asynchronous generator is of the pole changing type. Therefore it is able to run not only at rated speed, but also at a second, lower speed. This second speed has to be a fraction of small numbers of the high speed. This fraction is often $\frac{2}{3}$ of the first speed but it can also be $\frac{3}{4}$ [14].

The rated power of the generator in the low speed region is also much lower. It is typically $\frac{1}{5}$ to $\frac{1}{4}$ of the rated power in high speed operation [14]. This lower rated power of the generator is sufficient because the rotor cannot deliver its full power at the lower speed. The reason for this is that the rotor stalls at a constant ratio between wind speed and rotor speed. As the power of the wind grows with the third power of wind speed, this means that the maximum power the rotor can capture from the wind at two thirds of its rated speed is only $\left(\frac{2}{3}\right)^3 = \frac{8}{27} = 0.296$. This is a bit more than the

range of 0.2...0.25 for this power ratio found in [14], but if the low speed winding of the generator is overloaded the control of the wind turbine can always change to high speed operation.

Alternatively, it is also possible to use a second and smaller generator, which is only used in low speed operation [15, 37]. However, this requires not only the second generator, but very often also a second output shaft from the gearbox. So it is likely to be more expensive. An advantage of this possibility is that the lower rotor speed can be chosen freely, without the need that it has to be fraction of small numbers of the high speed, as it is with the pole-changing multispeed generator. However, it seems that this advantage does not compensate for the additional cost, as this second realization is not used very widespread. Therefore, it will not be considered any further in this study.

2.3 The active stall controlled single speed concept

In a stall controlled wind turbine, the power delivered by the turbine is determined by the aerodynamic properties of the rotor and the atmospheric conditions. The latest time at which corrections can be made is when the wind turbine is erected. But unfortunately neither the aerodynamic properties of the rotor blade nor the atmospheric conditions remain constant. The aerodynamic profile of the rotor blade is altered by erosion. The aerodynamic conditions change as the weather changes. One important factor in the aerodynamic conditions is the air density, which has an influence on the peak power which is captured from the wind when the stall effect occurs. As the air density is a function of the air temperature and the air pressure and as the former of the two changes in annual and daily cycles, the power level at which stall limiting occurs is not constant. As reference [28] shows, inaccuracies in the rotor profile during blade production can also have significant consequences for the maximum power.

In order to utilize the wind turbine and the grid connection as good as possible, rated power should be delivered whenever possible. This aim is reached by turning the rotor blades so that stall is caused or delayed as needed. Such a concept is shown in figure 3.

The rotor blades are turned via one small electric motor (it could also be a hydraulic actuator) and one gear per rotor blade. The motors can be small as the required pitch angles (the turn angles of the blades) all lie in a very narrow band which is only a few degrees wide.

Of course the pitch motors need energy, which has to be transmitted to the rotating part of the wind turbine. Sliprings are a common device for that. One drawback of them is that they cause wear and require maintenance.

The possibility to turn the blades so that they do not produce any more driving momentum offers the possibility to brake the wind turbine in case of emergency. Therefore, if the pitch drives of the different rotor blades are sufficiently independent, then the brake is no more critical with regard to safety. It is only needed to really stop the wind turbine, but not to brake it down. So the brake can be mounted on the fast shaft, and it doesn't need to absorb much energy. Such a brake will be much cheaper.

Another possibility of this concept is to turn the rotor blades to their optimum position with respect to the actual wind speed during partial load operation. Such

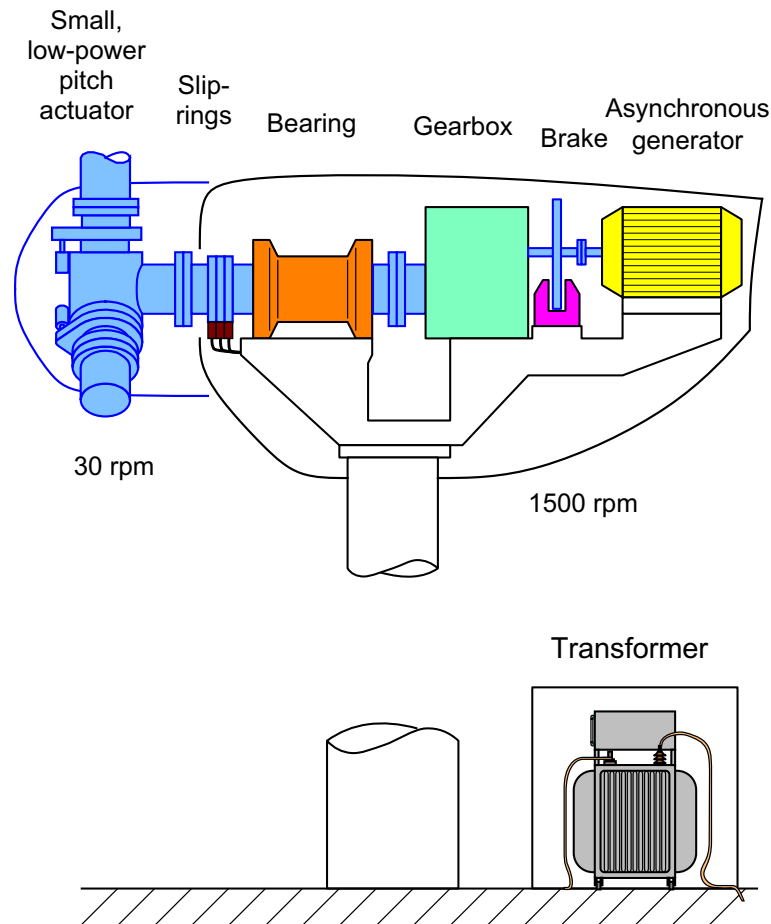

Figure 3: Typical mechanical layout of an active stall controlled single speed wind turbine

small movements can increase the rotor performance at low wind speeds.

2.4 The active stall controlled two speed concept

This concept is almost identical to the previous one. The only difference is that a pole-changing multispeed generator is used. Therefore, the same remarks apply as in sections 2.2 and 2.3.

2.5 The pitch controlled single speed concept

The difference between the active stall controlled concept described in section 2.3 and the pitch controlled concept which is described here is the direction of motion of the rotor blades when the power taken from the wind shall be reduced. The pitch controlled concept shown in figure 4 turns its rotor blades in the opposite direction (towards the angle of attack at which zero lift occurs), so that the aerodynamic forces on the blades are reduced. This leads to the necessary power reduction.

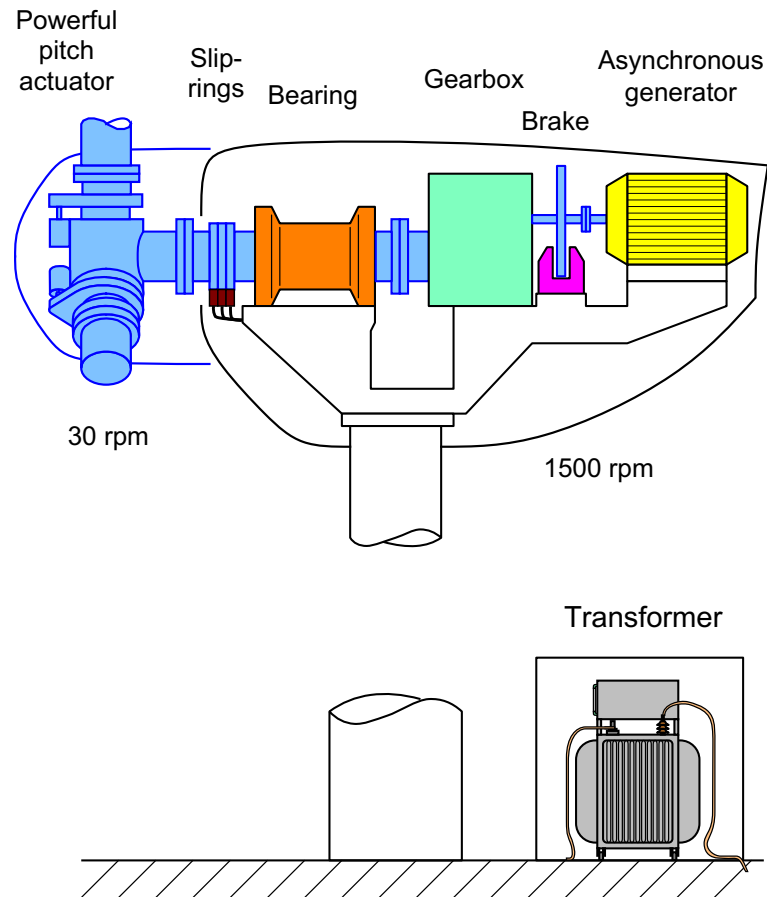

Figure 4: Typical mechanical layout of a pitch controlled single speed wind turbine

As mentioned above, the pitch drives for this concept must be much more powerful than for the active stall controlled concept. Therefore, they will also be more expensive.

An advantage of this concept is that the pitching of the rotor blades reduces all aerodynamic forces, while the stall reduces only the lift component. Therefore, pitching the blades leads to a general reduction of stress at high wind speeds. This not only applies to the blades, but also to the tower, as the rotor thrust is also reduced.

In large wind turbines, this concept can become problematic because the high inertia of the rotor blades makes it very difficult to achieve the needed fast turning of the blades.

2.6 The pitch controlled two speed concept

Again, this concept is almost identical to the previous one. The only difference is that a pole-changing multispeed generator is used. Therefore, the same remarks apply as in sections 2.2 and 2.5.

2.7 The stall controlled variable speed concept

To achieve variable speed operation, the stator frequency of the generator must be varied. This can be achieved using a frequency converter. Figure 5 shows one possible layout of such a concept.

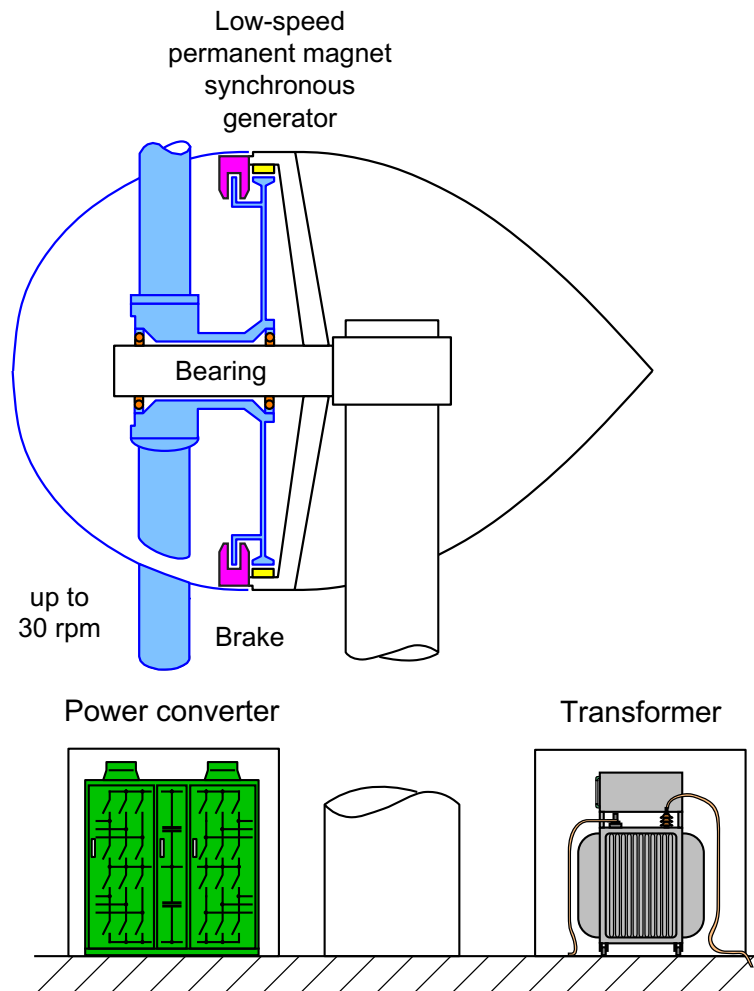

Figure 5: Typical mechanical layout of a stall controlled variable speed wind turbine

The usage of the frequency converter also allows to use a synchronous generator (although an asynchronous generator with gearbox as described in [50] is also possible), which can be built to run at the very low speed of the wind turbine rotor. Therefore, the gearbox can be omitted. The generator is then placed on the shaft which carries the rotor hub. This concept was chosen here for the comparison despite of its higher manufacturing cost mentioned in reference [8] because of its higher energy yield mentioned also there.

As the generator must have a very large diameter, it must be fixed to the shaft with a supporting structure. By building the shaft thicker and hollow, the bearing can be inside the shaft.

As the rotor blades are fixed on the hub and cannot be used for emergency braking,

the mechanical brake is critical with regard to safety. So it must be sufficiently large to achieve the needed torque and absorb the energy. But the large diameter of the brake is not a big problem, as the generator already has a large diameter anyway. However, the brake will be rather heavy and expensive, and a second emergency brake system is also needed, which might perhaps be electric (e.g. a brake chopper on the d.c. link.) .

If the generator is built with permanent excitation, no energy is needed for the excitation. Because there are also no pitch motors, no energy at all is needed on the shaft, so there are no sliprings. As a gearbox is also avoided, this concept doesn't require much maintenance. The cost of the permanent magnet generator may according to [16] be competitive in the future.

One drawback of this concept is the generator, which is not a standard machine but a custom design. Also, a power converter for the full power of the turbine is needed. Additionally, the permanent excited generator needs quite a lot of the expensive permanent magnets. But the main drawback is that in order to force the rotor into stall the generator must brake the rotor down while the wind speed increases. This means that the possible maximum torque of generator and power converter must be larger than the torque the wind turbine produces at rated power. Even though [39] shows that this drawback can be reduced by using appropriate rotor profiles and an intelligent control strategy, it still remains to some extent.

2.8 The pitch controlled variable speed concept

The variable speed concept with direct driven generator shown in figure 5 can of course be combined with pitch control. The result is shown in figure 6.

The rotor blades are again turned by rather powerful and fast pitch actuators. However, if the pitch mechanism cannot follow rapid wind speed changes, this is not as problematic as it is in a constant speed concept. In a variable speed system, the extra energy taken from the wind during a wind gust can to some extent be stored in the rotor inertia by increasing the rotor speed, while the power converter keeps the output power of the system constant. To do this, the generator and the power converter must be able to handle overspeed conditions. But as the power limiting is done by the pitch controller, no torque levels above rated torque are needed, which is an advantage when compared to the stall controlled variable speed concept.

Of course the synchronous generator can be of the permanent excited type, too, but as the energy for the pitch actuators has to be transmitted to the rotor anyway, an electrical excited generator is not that much of a drawback as it is in a stall controlled, variable speed concept.

As the pitch mechanism allows to slow down the rotor, the brake is again only a park brake and not critical with regard to safety.

The general reduction of aerodynamic forces by pitching the blades instead of stalling them, which was already mentioned in section 2.5, is of course also an advantage of this concept.

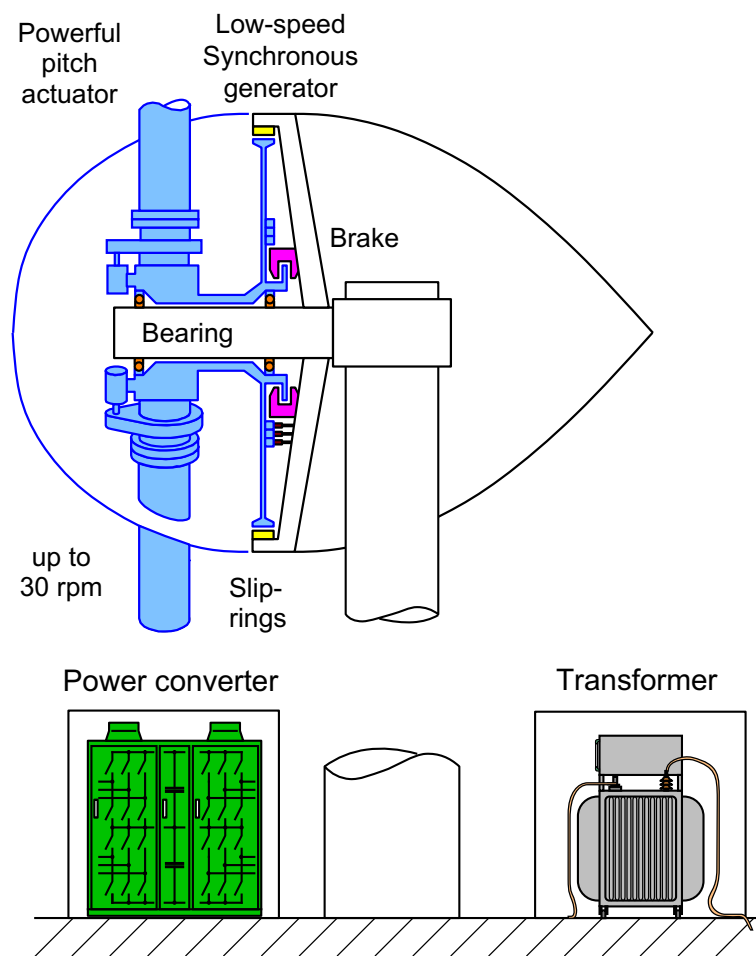

Figure 6: Typical mechanical layout of a pitch controlled variable speed wind turbine

3 Control concepts

In this section, the control concepts used in the simulations will be discussed in detail. However, it must be understood that it was not the aim of this work to reproduce the control concepts of special wind turbines and their respective manufacturers. This would have been at least very difficult, if not entirely impossible, because the manufacturers do not publish the necessary details of their control methods. While this is of course necessary for them to keep their individual lead over their competitors, it hinders such a comparative work as it is intended here.

But even if the necessary data could have been accessed, the use of real wind turbine control concepts would lead to another shortcoming: A comparison of the control concepts which are really used by wind turbine manufacturers would mix the benefits and drawbacks of the concepts with the advantages and disadvantages of the individual implementations of the manufacturers. In other words, such a study would lead to results like: “the controller which manufacturer A uses in wind turbine B gives so-and-so-much more energy when compared to the controller used by manufacturer X in wind turbine Y.” Obviously, this is not the aim of this study. Instead, the advantages and drawbacks of the general concepts are to be shown.

In order to do this, the control concepts used here need not to be exactly the same which are used in the industry. Instead, they should be chosen in order to show the differences between the general concepts as clear as possible.

In the following, a detailed discussion of the control of all concepts will be given. But first, figure 7 will be used to define some important quantities. It is a view from the blade tip towards the hub in a coordinate system moving with the blade.

The basis for the whole definition is the *true wind direction*, which is the wind direction without consideration of the rotation of the rotor (for the computations, the braking effect of the rotor on the wind has to be included in the length of the true wind vector, of course). If the yawing system works well, then the *rotation axis* of the rotor is aligned with the true wind direction⁹. As the rotor blade is spinning around this axis and our coordinate system is moving with the blade, there is a *rotational movement of the blade* which must be superimposed with the true wind to form the *apparent wind*. Of course the length of the rotational movement vector depends not only on the rotor speed, but also on the radius at which we look at the blade.

The apparent wind is the wind as seen by the blade and therefore the basis for all aerodynamic definitions. The blade is designed to have its profile axis in a certain direction, which is the *profile axis from rotor design*. The direction of this axis will be different for each station along the blade. In the concepts which are able to pitch the rotor blade, the blade may be turned away from this position. The turn angle is called the *pitch angle*, and as the blade cannot be twisted, the pitch angle is the same for the whole blade. The angle which is formed between the actual profile axis and the apparent wind direction is the *angle of attack*, which is important for the calculation of the aerodynamic behaviour of the blade section.

The apparent wind acting on the blade creates an *aerodynamic force*. This aerody-

⁹At least in the horizontal plane. If the turbine is located near a hill, then there might be a vertical component in the true wind direction which cannot be compensated for. However, this case is not modeled here, as will be described in more detail in section 4.

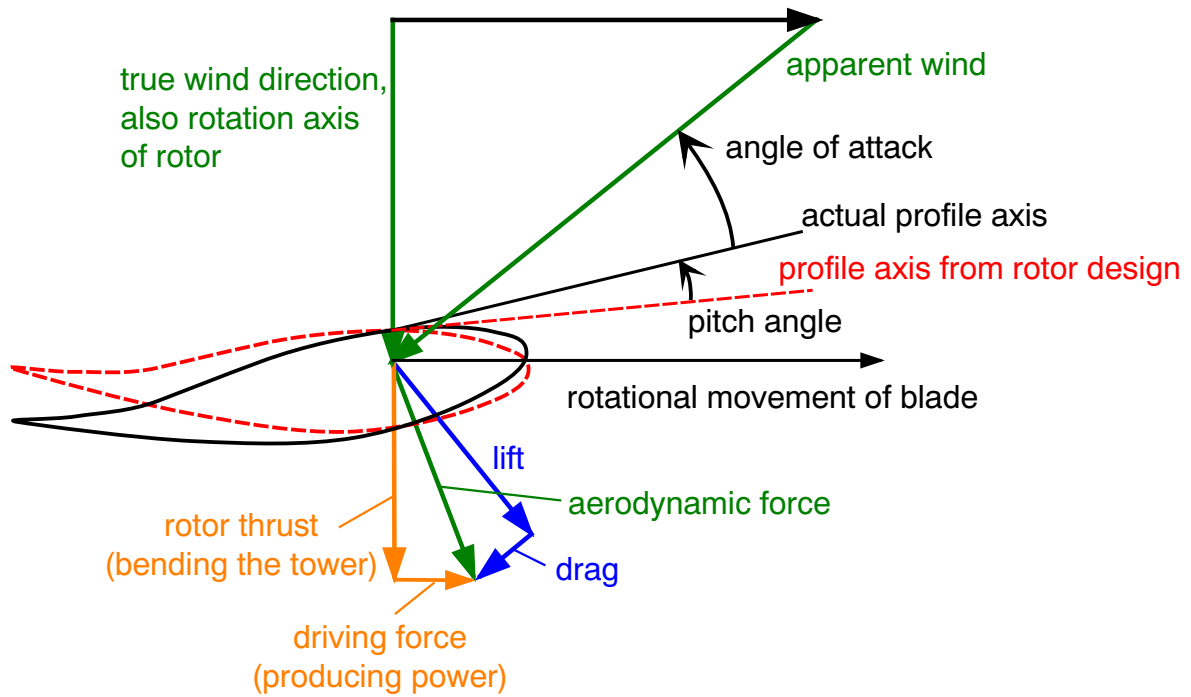

Figure 7: Definition of the aerodynamic forces and angles

dynamic force can be split up in two different ways. The first one is to use the apparent wind as the reference, which is usual in aerodynamics. Here, there is a usually large component orthogonal to the apparent wind, which is the *lift*. The component in the direction of the apparent wind is the *drag*.

The other possibility is to use the rotational movement of the blade (or the rotor plane) as a reference. Again, there is a force orthogonal to the reference which is the *thrust*. The thrust is transmitted via the rotor main bearings and is bending the tower. As can be expected, this force is unwanted, but unavoidable, as the rotor thrust can also be seen as the force resulting from braking down the wind flow¹⁰. The second component lies in the rotor plane. This is the *driving force*, which is turning the rotor and is used to gain energy¹¹.

3.1 Control for constant speed concepts

The “speed control” of a constant speed concept is done by the asynchronous generator, which translates the frequency of the electric grid into the mechanical synchronous speed. The actual speed of a real wind turbine follows from the synchronous speed

¹⁰When the wind is braked down, its impulse is reduced. This impulse reduction needs an opposing force, which is the rotor thrust.

¹¹The needed opposite force is created by a change in the winds impulse, so that the air is leaving the wind turbine in an eddy with a turning direction opposite to that of the rotor.

and the slip of the generator. However, in the simulations the slip and the possible frequency variations of the grid were neglected (because they are rather small) so that the rotor speed is constant.

For the single speed concepts there is no need for any more speed control.

In contrast, the two speed concepts need some sort of controller which decides whether the generator should run in high speed or in low speed mode. This controller should be designed so that it always chooses the speed level which will yield the highest energy capture under the current wind conditions.

Unfortunately, the controlled system is of extremely low dynamic performance, because switching a wind turbine with a pole-changing asynchronous generator from one speed to the other is a time consuming procedure. Especially switching from high speed mode to low speed mode might also need the assistance of the mechanical brakes, which causes wear and the loss of a part of the kinetic energy stored in the rotor inertia. Therefore, this speed shifting may not be done too often, especially not for every single wind gust. So the switching decision must be based on wind speed averages over a longer time interval, which may for example be 10 minutes.

Even though the need to limit the number of switching actions may be troublesome in reality, it makes the simulation of this controller much easier. As the simulations are always done with a predefined average wind speed (as will be described in more detail in section 4.1), the appropriate rotor speed is known before the simulation is started. Therefore, the rotor speed can be set to the proper value before the simulation starts, and it remains at this value all over the simulation. This means that the controller which is responsible for changing the speed is not needed in the simulation at all. Instead, only the knowledge which rotor speed to use at which wind speed is needed. This knowledge can be gained from two previous simulation runs, one with low speed and one with full speed. For each wind speed the rotor speed will be chosen which gives the higher average output power.

However, even this initial decision may be influenced by site conditions like the turbulence. While it might be possible to conceive concepts which adapt to the actual site conditions by some sort of learning, for this comparison it was thought to make more sense to have one control concept with fixed parameters for each wind turbine concept¹². As two of the three standards for power curve measurements presented in [42] lead to a rejection of the data if the turbulence is above 15%¹³, it was assumed that a turbulence of 10% is a good reference value. So the decision which rotor speed to use is based on the energy capture at 10% turbulence.

In the following, the details of the control system responsible for selecting the pitch angle are discussed.

¹²This decision was not fully free, as the learning process of a possible adaptive controller would have taken much longer than the simulated time of 5 minutes at each wind speed, because the learning process must also be based on average values. So the necessary simulation time would have been increased excessively by an adaptive controller.

¹³The turbulence intensity or in short terms the turbulence is defined as the standard deviation of the wind speed divided by the average wind speed.

3.1.1 The stall controlled concepts

As a passive stall controlled concept has its rotor blades fixed to the hub, there is no way to influence them during operation. Therefore, no kind of pitch controller is required for this concept.

3.1.2 The active stall controlled concepts

In reality, the active stall controlled concepts need a controller for their pitch angle which has to react to the output power. Because in the simulation model the output power is linked to the rotor power via a simple loss equation (see section 4.8 for details), it doesn't matter whether the controller reacts to the output power of the wind turbine or to the power at the rotor shaft. In order to make the model as simple and clear as possible, the latter was chosen for the simulation.

Reference [37] tells that the pitch controllers found in real wind turbines are of the PID type¹⁴, because they have to react not only to the actual power level but also to the power slope. But according to [37], even these complicated controllers suffer from stability problems because of the short response time which is required by the wind turbines. The reason for these stability problems is the influence of the wind speed on the gain of the controlled system. In other words, if a certain change in pitch angle results in a given change in output power at rated wind speed, then the same change in pitch angle will result in a much larger change in output power at higher wind speeds. The change in output power at high wind speeds can be many times the one at rated wind speed. Therefore, these controllers must continuously be adapted to the variation of the control loop gain inflicted by the wind speed changes. As a result, such control systems are very complex. It is also clear that a mistuning of such a controller may also influence the energy capture of the wind turbine.

As mentioned above, the main aim of this study was not to represent the control system of real wind turbines as exactly as possible, but rather to show the basic characteristics of the different concepts. Therefore, the controllers should allow to see these characteristics as clear as possible¹⁵. This was achieved in the following way:

The main restriction for the dynamic response of the pitch control system is the speed with which the rotor blades can be turned. This speed cannot be too high, because turning the large rotor blades at high speeds would require pitch actuators of prohibiting size and cost. As no controller can be faster than the actuator, the best possibility to show the characteristics of the system would be to use always the highest possible pitch speed. This leads to a two-level controller. It showed up that a two-level controller was too simplistic, so it was extended to a multi-level controller, which is shown in table 3. For a real wind turbine, this controller might not be well suited because the variable frequency of changes between the different levels could excite eigenfrequencies of the rotor blades torsion mode. But in a simulation with the rotor blades assumed to be ideally stiff, it works very well. It will now be described in detail.

¹⁴Reference [37] speaks indeed of PID controllers. As ideal PID controllers cannot be built in reality, probably PIDT₁ controllers are chosen for realization.

¹⁵This was also the reason for choosing a controller reacting on actual values and not on average power values, which is also possible for active stall controlled systems.

Table 3: Multi-level pitch controller for the active stall controlled concepts

con- dition	$P_R < 640kW$		$640kW \leq P_R$ and $P_R \leq 645kW$		$P_R > 645kW$
	$v_w < 15m/s$		$v_w \geq 15m/s$		
	$P_R < 635kW$	$635kW \leq P_R$ and $P_R \leq 640kW$			
ac- tions	fetch $\alpha_{opt}(P_R)$ from table, $\frac{d\alpha}{dt} = (10s^{-1} \cdot$ $(\alpha_{opt}(P_R) - \alpha))$	$\frac{d\alpha}{dt} = +2^\circ/s$	$\frac{d\alpha}{dt} = +2^\circ/s$	$\frac{d\alpha}{dt} = 0$	$\frac{d\alpha}{dt} = -2^\circ/s$
	limit $\frac{d\alpha}{dt}$ to the range of $-2^\circ/s \dots +2^\circ/s$				
drive	$\alpha = \int \left(\frac{d\alpha}{dt} \right) dt$				

The power values given in table 3 and in the following tables have been chosen experimentally during the calibration process, which will be described in section 4.9. This means that they were chosen so that the maximum output power (fed to the grid) for a turbulence intensity of 10% is between $600kW$ and $605kW$. The values given here are valid only for the aerodynamic profile Goettingen (Goe) 758 and a design tip speed ratio of 6, which was used for the majority of the simulations.

If the power at the rotor shaft P_R exceeds its upper limit of $645kW$, the rotor blades are turned in negative direction, which increases the angle of attack. So the stall is enforced on a larger part of the rotor blade and the parts already in stall go deeper into it. As a result, the lift of the profiles is reduced, which finally leads also to a reduction of torque and power of the rotor.

Just below this power level which calls for power reduction is the power band which should be established and maintained. So, if the power lies within this band, nothing is to be done and the pitch angle is kept constant.

If the power is too low, than a decision is made according to the wind speed. If the wind speed is above $15m/s$, than there is enough power in the wind and all we need to do is turn the rotor blades in the positive direction to reduce the angle of attack and therefore increase the rotor power P_R .

In case the wind speed is below $15m/s$, than another decision based on power is performed. If the power is just a bit too low there is a good chance that we can increase the power by turning the rotor blades in the positive direction and thereby reducing

the stall. If this attempt fails, the power will decrease further and go below $635kW$, so that this effort is ended.

If the power is below $635kW$, then it is clear that the wind is simply not strong enough to provide rated power. Therefore, partial load operation mode is entered which tries to optimize the output power by turning the rotor blades to their optimum pitch angle for any given wind speed¹⁶. The desired pitch angle is fed into a proportional controller¹⁷ which delivers the desired speed value for the pitch drives.

However, the wind speed cannot be measured very accurately on a wind turbine without extensive cost. So it is not practical to select the optimum pitch angle as a function of wind speed. But this problem can be easily solved by exploiting the fact that the wind speed and the rotor output power are linked unambiguously to each other for all wind speeds below rated wind speed¹⁸. Therefore, the optimum pitch angle can also be plotted as a function of the rotor output power (see figure 17 for an example). Such a function is used here in form of a table with linear interpolation between the data points. In reality, the power at the rotor shaft could be gained from a calculation based upon the power fed to the grid and a loss equation, or the characteristic of the optimum pitch angle can also be plotted as a function of the power fed to the grid.

The optimum pitch angle characteristic (e.g. the one shown in figure 17) shows slopes in both directions and even a changing sign. As the input of this characteristic is the rotor power, which is itself a function of the pitch angle delivered by this characteristic, there could be stability concerns. However, within this closed loop there is also the rotor characteristic (e.g. the one shown in figure 16). This characteristic (or, to be more exact: the trace through this characteristic which is given by the pitch angle characteristic) provides the necessary inverse of the pitch angle characteristic so that the overall system remains stable.

What also needs consideration here is how to handle the selection of the optimum pitch angle when a two-speed system is running in low speed mode. There are two main possibilities:

- The first one is simply to use two different optimum pitch angle versus rotor power characteristics, one for each speed.
- The second one is a bit more complicated, but eliminates the need for a second characteristic. According to [15, 37], in the ideal theory (with the influence of the Reynolds-number neglected), the rotor will have exactly the same performance if the tip speed ratio λ remains constant. The tip speed ratio λ is defined as

$$\lambda = \frac{v_T}{v_w}, \quad (1)$$

¹⁶Although in reality most systems optimize their pitch angle based on average values, here an approach of following the actual values was chosen in order to show the maximum potential of this technique.

¹⁷A proportional controller is sufficient here to reach a state without remaining deviation as the system is itself of integral-action type.

¹⁸This relation is influenced by the variations in the air density in reality, but as the air density variations which are caused by the weather are not too large, the relation can be used as a very good approximation for one site. It is at least much more accurate than the direct wind speed measurement by the usual nacelle anemometer.

where v_T is the speed of the tip of the rotor blade (caused by the rotation) and v_w is the wind speed. Therefore, if the rotor speed is reduced by a factor of f (e.g. $f = \frac{2}{3}$), then the rotor will have the same aerodynamic conditions and therefore the same optimum pitch angle at a wind speed which is also lower by a factor of f . On the other hand, the power which can be delivered by a wind turbine is generally

$$P_R = \frac{1}{2} \rho A_R v_w^3 c_P, \quad (2)$$

where ρ is the air density, A_R is the rotor area (i.e. the area swept by the blades) and c_P is the power coefficient¹⁹. The factor c_P is dependent on the aerodynamic behaviour of the blades, so that it can also be said that $c_P = c_P(\alpha, \lambda)$, where α is the pitch angle. If we keep λ and α constant, but reduce the rotor speed and the wind speed by the factor f , it can be concluded that c_P remains constant. This means that if the power delivered by the rotor at the high rotor and wind speed (index 1) was

$$P_{R1} = \frac{1}{2} \rho A_R v_{w1}^3 c_P, \quad (3)$$

at the low rotor and wind speed it will become (index 2):

$$P_{R2} = \frac{1}{2} \rho A_R v_{w2}^3 c_P = \frac{1}{2} \rho A_R (f \cdot v_{w1})^3 c_P = f^3 P_{R1} \quad (4)$$

This means that if we normalize the rotor power by f^3 , we can use the same characteristic for all rotor speeds.

After the reference pitch speed is established, it is limited to the speed available from the pitch drives, which is $2^\circ/s$. This is the lowest speed which [37] mentions for pitch drives, but it has proven to be more than enough here. Of course this limitation is only needed for the proportional controller, but for ease it is always in action, as it does no harm.

What is not shown in table 3 is that the reference speed for the pitch actuators is set to zero if a rotor blade passes in front of the tower and if the power is high (above $665kW$). The reason for this is that when the wind speed is high and the rotor blades are deeply stalled, then the reduction in wind speed in front of the tower *reduces* the angle of attack and therefore *increases* the output power of the rotor. But if the controller would react to each rotor blade passing in front of the tower, the result would be a permanent pitching of the blades without much success, as the pitch drives are anyway too slow to follow this sharp decrease in wind speed. Therefore, it is best to do nothing and wait until normal conditions are reached again.

In the end the pitch actuators are modeled as being ideal and just providing the pitching speed required. The pitch angle is then the integral of the pitching speed.

When this controller is compared to the one for pitch-to-feather depicted in table 4, the main difference is the decision based upon wind speed in the low power area. This decision is very necessary for the active stall controlled concept, as the pitch angle required to provide rated power at higher wind speeds (much above rated wind speed) is about the same as the optimum pitch angle which would be fetched from the table in

¹⁹It should be noted that the power coefficient can never become larger than $\frac{16}{27}$ [15, 37].

the low wind speed, low power case. Therefore, simply using the value from this table would possibly not lead to required control action. In fact, there are cases where the blades would be pitched in the wrong direction! The introduction of the wind speed as a decision criterion here might seem contradictory to the above statement that the wind speed cannot be measured accurately on a wind turbine. However, no accurate measurement is needed here, as any value between rated wind speed (which is around $10.5m/s$ for zero turbulence) and the given value of $15m/s$ will work. So only a very rough estimate of the wind speed is needed here, which can be gained from the nacelle anemometer.

3.1.3 The pitch controlled concepts

In this section, the multi level controller for the pitch controlled concepts shown in table 4 will be described in detail. It can be easily seen that this controller is very similar to the one for the active stall controlled concepts depicted in table 3, except for the simpler part at low power levels and the opposite sign for the pitch speed reference.

Table 4: Multi-level pitch controller for the pitch controlled concepts

condition	$P_R < 632kW$	$632kW \leq P_R \leq 637kW$	$P_R > 637kW$
actions	fetch $\alpha_{opt}(P_R)$ from table, $\frac{d\alpha}{dt} = 10s^{-1} \cdot (\alpha_{opt}(P_R) - \alpha)$	$\frac{d\alpha}{dt} = 0$	$\frac{d\alpha}{dt} = 6^\circ/s$
	limit $\frac{d\alpha}{dt}$ to the range of $-6^\circ/s \dots +6^\circ/s$		
drive	$\alpha = \int \left(\frac{d\alpha}{dt} \right) dt$		

If the power is too high, which is above $637kW$ ²⁰, the rotor blades are turned in the positive direction. This results in a lower angle of attack and therefore in a reduction of the aerodynamic forces acting on the blades, which in consequence leads to the necessary reduction of the power at the rotor shaft and the output power fed to the grid.

In case the power is lower (between $632kW$ and $637kW$), it falls within the tolerance band. Therefore, no action is needed and the pitch angle is not altered.

If the power is too low, the controller switches to power optimization mode and tries to get the biggest possible shaft power. In this mode, the reference pitch angle is taken from the same table as mentioned above for the active stall controlled concepts. This simplification is possible here as the pitch angles for power limitation are far away (several degrees to some tens of degrees) from the pitch angles used for power

²⁰The different values when compared to the controller used for the active stall controlled concepts are a result of the different dynamic behaviour and the demand to reach the same maximum output power for 10% turbulence. Again, the values are valid only for the rotor profile Goettingen 758 and a design tip speed ratio of 6.

optimization. Therefore, the simple proportional pitch controller used for this will order very large pitch speeds when turning the blades back from a previous power limiting condition.

These large reference pitch speeds are then limited to the abilities of the assumed pitch actuators in the pitch speed limiting, which again has only influence if the proportional controller is selected. However, the speed of the pitch actuators has to be three times higher than in the active stall controlled concept, and when looking at the time traces given in section 5 it can be concluded that this is still the absolute minimum.

Again, what is not depicted in table 4 is a blocking device which sets the pitch speed to zero if there is a rotor blade in front of the tower and the power is high.

Finally, the pitch speed is integrated to form the pitch angle.

3.2 Control for variable speed concepts

It is obvious that the variable speed concepts need a speed controller. The tasks of this speed controller are common for both variable speed concepts in the case of partial load conditions. Therefore, the same control strategy is used for both of them here.

The tasks which should govern the choice of speed under partial load conditions are mainly two:

- The first task is to maximize the energy captured from the wind.
- The second one is to provide the output power as smooth as possible (and to reduce the mechanical loads).

Unfortunately, as already [48, 49] mention, these two targets are contradictory. The reason will be described in the following:

In order to maximize the energy capture, the tip speed ratio $\lambda = \frac{v_T}{v_w}$ should always be kept constant at its optimum value λ_{opt} . On the other hand, the tip speed v_T is $v_T = r_R \Omega_R$, where r_R is the rotor radius and Ω_R is the rotational speed of the rotor. Putting both equations together, we get:

$$\lambda = r_R \frac{\Omega_R}{v_w} \quad (5)$$

If λ is to be kept constant, this means that the rotor speed Ω_R must always be proportional to the wind speed v_w . If the wind speed increases fast during a wind gust, the rotor speed should follow immediately. However, this fast acceleration of the rotor may need more power than the wind delivers to the rotor. Therefore, it would be necessary to get the additional power from the grid, which would obviously violate the target of a smooth time characteristic of the output power.²¹

A compromise between the two contradictory targets has to be chosen, and this will be done in the way proposed in [13, 35, 48]. The power inherent in the wind is given in equation 2 which is repeated here:

²¹Not to mention the difficulty of measuring the wind speed explained in [13, 35]

$$P_R = \frac{1}{2} \rho A_R v_w^3 c_P \quad (6)$$

Introducing 5 solved for the wind speed delivers:

$$P_R = \frac{1}{2} \rho A_R r_R^3 \frac{\Omega_R^3}{\lambda^3} c_P \quad (7)$$

As we want λ to be optimal in steady state conditions, we set it to λ_{opt} . If the rotor is running at this optimum tip speed ratio, it will also run at its maximum power coefficient $c_{P,opt}$. Additionally, we can express the rotor area by the rotor radius ($A_R = \pi r_R^2$) and we obtain:

$$P_R = \frac{1}{2} \rho \pi r_R^5 \frac{\Omega_R^3}{\lambda_{opt}^3} c_{P,opt} \quad (8)$$

If we now use the mechanical relation $P_R = \Omega_R T_R$, solve it for T_R and introduce 8 into it, we get:

$$T_R = \frac{P_R}{\Omega_R} = \frac{1}{2} \frac{\rho \pi r_R^5 c_{P,opt}}{\lambda_{opt}^3} \Omega_R^2 \quad (9)$$

As except for Ω_R all quantities on the right side are constants, we can mix them together into a new one and obtain:

$$T_R = C \Omega_R^2 \quad \text{with} \quad C = \frac{1}{2} \frac{\rho \pi r_R^5 c_{P,opt}}{\lambda_{opt}^3} \quad (10)$$

Although these equations were derived for steady state, in the controller they are also used under transient conditions. The controller takes simply the rotor speed Ω_R as input and calculates the generator reference torque T_G^* as $T_G^* = C \Omega_R^2$. As stated in [48], this method gives lower mechanical stress than a control aiming at constant λ .

The power converter and the generator are assumed to be ideal, so that the desired generator torque acts immediately on the rotor shaft. The reason for this simplification is that the time constants of the power converter and the generator are very small when compared to the mechanical time constant which results from the rotor inertia.

The problem of determining the constant C for a real wind turbine mentioned in [13] is also solved in [13] by introducing a controller which finds the optimum by itself. Therefore, C is assumed to be known here.

When rated power is approached, the power optimization has to be replaced by the power limiting, which will be described in the next two sections.

3.2.1 The stall controlled concept

For the stall controlled variable speed concept, the generator torque T_G is the only possibility of influencing the rotor and thereby the power taken from the wind. As overspeed of the turbine in this concept always includes the danger of getting more than rated power from the wind (which will lead to a further speed increase), the torque controller must be designed so that it ensures a safe operation of the wind turbine under all circumstances. The details of the design of this controller are given

in reference [39]. Here, only the resulting controller is depicted in table 5 and will be explained.

Table 5: Torque controller for the stall controlled variable speed concept

action	$T_{G1}^* = C\Omega_R^2$		
condition	$v_w < 10m/s$	$10m/s \leq v_w < 12m/s$	$v_w > 12m/s$
actions	$P_G^* = 560kW$	$P_G^* = 560kW + 60\frac{kW}{m/s} \cdot (v_w - 10m/s)$	$P_G^* = 680kW$
	$\Delta P_G = P_G^* - P_R$		
	$\Omega_{Ri}^* = \int K_{iP} \Delta P_G dt$, limited to $[0, 1.5\Omega_{Rr}]$		
	$\Omega_R^* = K_{pP} \Delta P_G + \Omega_{Ri}^*$, limited to $1.14\Omega_{Rr}]$		
	$T_{G2}^* = K_{p\Omega}(\Omega_R^* - \Omega_R) + T_{R,obs}$		
	$T_G^* = \max(T_{G1}^*, T_{G2}^*)$, limited to $2\frac{P_{Gr}}{\Omega_{Rr}}$		

First, the reference torque T_{G1}^* for partial load operation is calculated from the rotational speed of the rotor.

As explained in [39], a good possibility of avoiding extreme power peaks is to limit the reference power based on the wind speed. The described wind turbine controller uses this method, where the reference power fed to the power controller is selected based on the wind speed. This situation is depicted in figure 8 and could be called "cutting the edge of the steady state power curve". The normal power curve would be the curve of P_R in figure 8 for partial load (left of the intersection with the dotted line) and the dotted and later solid curve of a constant P_G^* for wind speeds above rated wind speed. However, just at the change from partial load operation to rated power operation the rotor has to be slowed down very quickly, while the wind is likely to increase further, which increases the rotor power and thereby increases the needed generator torque for slowing down even more. To avoid this excessive torque²², the solid curve is used for P_G^* . Thereby, the change from power optimization to power limiting occurs at a somewhat lower power level, thereby avoiding the need of excessive torque.

In the next step of the controller, the system deviation ΔP_G of the power is calculated. The following two lines are the implementation of a power controller of PI-type which provides a rotor speed reference. This forms the outer loop of a cascaded control. The integrator of the power controller is limited to avoid it from drifting away during partial load phases, where the average of the deviation is not zero. The output of the

²²The high torque needed here would lead to a very expensive design, as the power converter cannot be overloaded. Therefore, it has to be designed to match the needed peak torque.

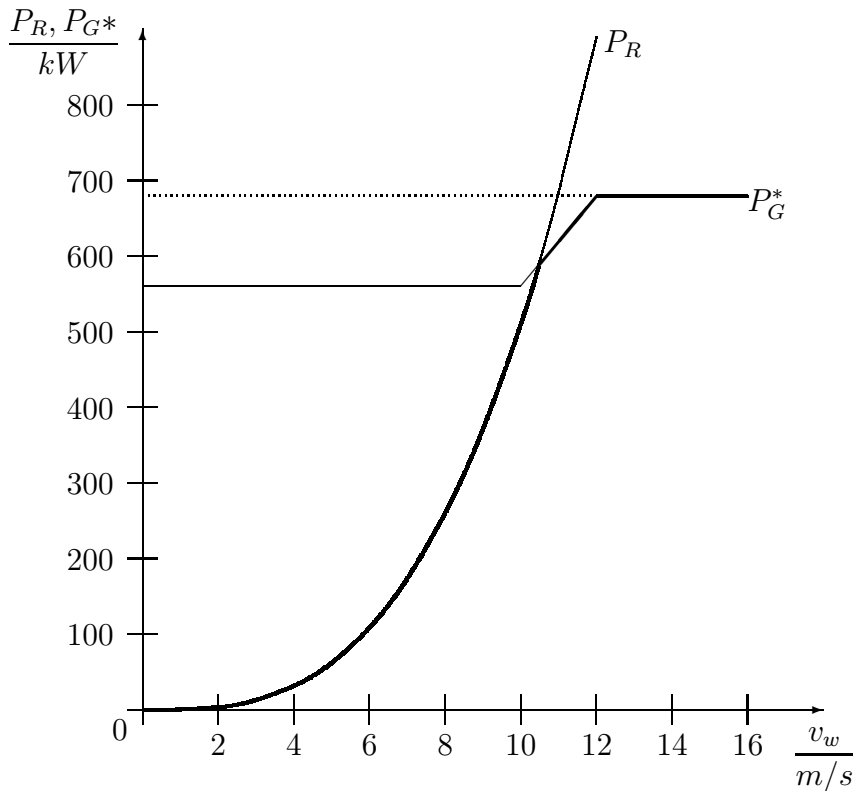

Figure 8: "Cutting the edge of the power curve" for the stall controlled variable speed system

entire controller is also limited to prevent the controller from asking for very high and potentially dangerous rotor speeds.

The speed controller, which forms the inner loop of the cascaded control, is a simple P-type controller with a pilot control of the rotor torque²³. The speed controller provides its reference torque T_{G2}^* based on the actual need of power limiting.

Finally, the larger of the two reference torque values is selected and limited to twice the rated torque. This selection is equal to the selection of the lower of the two curves in figure 8, which is the aim of the control system.

However, two of the quantities used in this control system need further attention because they are not easy to measure. The first one is the wind speed. The wind speed needed here is the average wind speed over the rotor area and in the rotor plane, but unaffected by the rotor. This quantity cannot be measured by anemometers because an anemometer close to the rotor plane would be affected by the rotor, and an anemometer sufficient far in front of the rotor would suffer from a time lag, as it would measure the wind some time before it interacts with the rotor and there would also only be a limited correlation between the two wind speeds. Also several anemometers would be needed to provide an average value of the wind speed of the rotor area, which is out of question due to economical reasons. As [35] puts it "the only true wind speed

²³The P-type controller is sufficient here, as the system has itself I-characteristic and the disturbance is compensated by the pilot control.

measurement device of a wind turbine is its rotor”.

Fortunately, the usage of the rotor as a wind speed measurement device is easier in a stall regulated system with rotor blades fixed to the hub, as the power coefficient c_P is only a function of the tip speed ratio λ . However, this function cannot be simply inverted, as its inversion is ambiguous. Fortunately, the disturbance in the wind field which is created by the tower can be used as a means to solve these ambiguities. The detailed procedure is given in reference [22].

The second quantity which is impossible to measure directly is the rotor torque T_R respectively the rotor power P_R . This is *not* the torque at the rotor shaft, which would be easy to measure, but it is the aerodynamic torque acting on the rotor blades. This torque cannot be measured directly, as a part of it accelerates the rotor itself and is therefore not acting on the shaft. However, the rotor torque can be calculated from the generator torque and the rotor speed, if the rotor inertia Θ_R is known. The relation is:

$$T_R = T_G + \Theta_R \frac{d\Omega_R}{dt} \quad (11)$$

While this relation is simple, differentiation always introduces an amplification of noise as well as the risk of instability in the system. Therefore, it is better to use the rotor torque observer given in [39]. This rotor torque observer is depicted in figure 9.

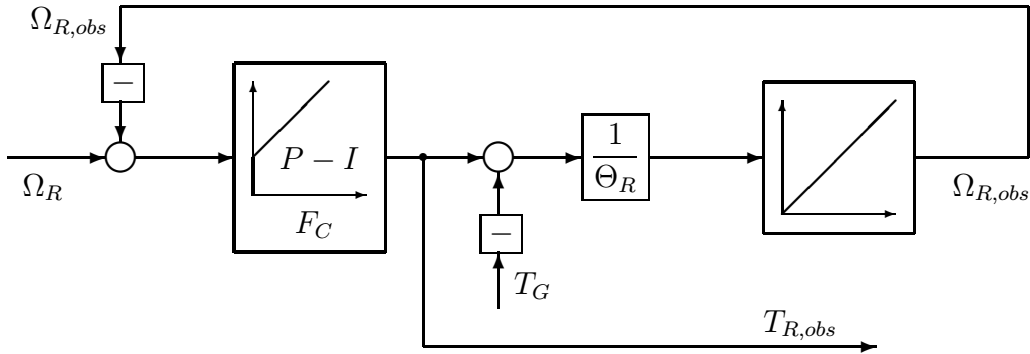

Figure 9: The rotor torque observer described in [39]

The idea of this observer is to replace the differentiation by an unproblematic integration and to use a controller to adjust the input of the integrator so that the outcome of the integrator becomes the same as the value which is to be differentiated. The output of the controller is then taken as the derivative of the output of the integrator.

In more detail, the right part of figure 9 is a model of the real rotor. The generator torque T_G is subtracted from the (observed value of the) rotor torque $T_{R,obs}$. After division by the rotor inertia Θ_R this value is integrated and leads to an estimation of the rotor speed $\Omega_{R,obs}$. The difference between the real rotor speed (which must be measured) Ω_R and this estimation is fed into a P-I-controller, which tries to adjust the observed rotor torque $T_{R,obs}$ so that the estimated rotor speed becomes equal to the measured value. If this relation would always hold and the model could be ideal, then the observed torque would be exactly the torque acting on the rotor blades. Of course,

this is impossible because the controller needs an input signal in order to make any change in the observed rotor torque.

The P-I-controller is necessary here in spite of the fact that the system is itself already integrating, because the generator torque T_G acts as a disturbance which is also integrated. Therefore, the system must be able to cope with a disturbance of ramp type for the controlled quantity (which is Ω_R). This requirement leads to a doubly integrating system, and therefore to a PI-controller.

In order to make the system response independent of the rotor inertia Θ_R , this rotor inertia should be compensated in the controller. One possible choice of parameters for the controller is:

$$F_C = \Theta_R \frac{1 + 2st_{obs}}{st_{obs}^2} \quad (12)$$

With this choice, the whole system behaviour depends only on the single parameter t_{obs} . The transmission function of the open system becomes then

$$F_O = \frac{2st_{obs} + 1}{s^2 t_{obs}^2}, \quad (13)$$

and the transmission function of the closed loop becomes:

$$F_W = \frac{2st_{obs} + 1}{s^2 t_{obs}^2 + 2st_{obs} + 1} \quad (14)$$

The denominator shows that the system is of second order and has a damping of $\sqrt{\frac{1}{2}}$. However, this is the transfer function between Ω_R and $\Omega_{R,obs}$. What is more interesting here is the relation for $T_{R,obs}$, which can be found as:

$$T_{R,obs} = T_G + \Theta_R \frac{2s^2 t_{obs} + s}{s^2 t_{obs}^2 + 2st_{obs} + 1} \Omega_R \quad (15)$$

The behaviour of this system in the first moment $t \rightarrow 0$ after a step change of Ω_R can be found by looking at the case $s \rightarrow \infty$ in equation 15, which leads to $T_{R,obs}(t \rightarrow 0) = T_G + \frac{2\Theta_R}{t_{obs}} \Omega_R$. This shows that the approximation of an ideal differentiation becomes the better the smaller t_{obs} becomes. For the simulations, t_{obs} was selected sufficiently small ($t_{obs} = 10ms$) so that the wind speed observer is able to work.

It can also be seen in equation 15 that if the system runs at a constant Ω_R for an infinite time $t \rightarrow \infty$ (which corresponds to $s \rightarrow 0$) the observed torque becomes $T_{R,obs}(t \rightarrow \infty) = T_G$, as it is expected.

One final note can be given on the generator torque T_G : if the torque control of the generator is sufficiently fast and of high control quality, then the generator torque doesn't need to be measured, as it can also be replaced by its reference value T_G^* .

3.2.2 The pitch controlled concept

The torque controller for the pitch controlled variable speed concept is of course much simpler than for the stall controlled concept, as it is not necessary to force the wind turbine rotor in the stall. The resulting controller is shown in table 6.

Table 6: Torque controller for the pitch controlled, variable speed concept

action	$T_{G1}^* = C\Omega_R^2$	
condition	$P_{G1}^* = T_{G1}^*\Omega_R \leq 671kW$	$P_{G1}^* = T_{G1}^*\Omega_R > 671kW$
action	$T_G^* = T_{G1}^*$	$T_G^* = \frac{671kW}{\Omega_R}$

It uses simply the relation that in partial load operation the reference torque should be proportional to the square of the rotor speed, which was derived above. If the power becomes larger than $671kW$ (which is the rated power divided by the rated efficiency of the variable speed system), the controller switches to power limiting mode and sets the reference torque so that the mechanical power absorbed by the generator leads to rated electrical output power²⁴.

As the torque controller is only concerned with adjusting the output power, the rotor speed will not be controlled by it. Instead, this is the task of the pitch controller described in table 7. As can easily be seen from the table, this controller is rather complicated. Therefore, it is also illustrated in figure 10.

As the task of this controller is to keep the rotor speed in a tolerance band, the uppermost two lines together with the lowest two lines of table 7 are what might be expected at first glance. As can also be seen in the upper diagram of figure 10, the first two lines of table 7 realize a simple three level controller which turns the rotor blades to higher pitch angles if the rotor speed becomes too high and towards lower pitch angles if the rotor speed becomes too low. The integration in the second last line of table 7 forms the pitch angle from the controller output. It must be seen in conjunction with the last line, so that it is a limited integrator which cannot go below a pitch angle of zero²⁵.

The transition values of the three-level controller were determined in the following way: First, from the equations in the first two lines of table 6 the power in partial load operation can be found as a function of the rotor speed:

$$P_G = T_G\Omega_R = C\Omega_R^3 \quad (16)$$

This equation is now solved for Ω_R and leads to:

$$\Omega_R = \sqrt[3]{\frac{P_G}{C}} \quad (17)$$

For the rotor profile Goettingen Goe 758 and a design tip speed ratio of 6, the

²⁴As the rotor speed should not vary too much in full load condition, the influence of the rotor speed Ω_R on the system efficiency is neglected in the controller. Therefore, the reference mechanical input power of the generator is the constant of $671kW$.

²⁵Negative pitch angles would cause the rotor to stall in partial load operation. Therefore, they have to be avoided.

Table 7: Pitch angle controller for the pitch controlled variable speed concept

condition	$\Omega_R < 3s^{-1}$		$3s^{-1} \leq \Omega_R \leq 3.15s^{-1}$		$\Omega_R > 3.15s^{-1}$	
action	$\frac{d\alpha}{dt} = -6^\circ/s$		$\frac{d\alpha}{dt} = 0$		$\frac{d\alpha}{dt} = +6^\circ/s$	
	$P_{R,obs} = T_{R,obs}\Omega_R$					
condition	$P_{R,obs} < 400kW$	$400kW \leq P_{R,obs} \leq 500kW$	$500kW < P_{R,obs}$ and $P_{R,obs} < 700kW$	$700kW \leq P_{R,obs} \leq 800kW$	$P_{R,obs} > 800kW$	
flags	$Fl_+ = \text{false}$	$Fl_+ = \text{false}$	$Fl_+ = \text{false}$		$Fl_+ = \text{true}$	
	$Fl_- = \text{true}$		$Fl_- = \text{false}$	$Fl_- = \text{false}$	$Fl_- = \text{false}$	
condition	$Fl_- = \text{true}$		$Fl_- = \text{false}$ and $Fl_+ = \text{false}$	$Fl_+ = \text{true}$		
action	subtract $6^\circ/s$ from $\frac{d\alpha}{dt}$			$\frac{d\alpha}{dt} = +6^\circ/s$		
	limit $\frac{d\alpha}{dt}$ to the range of $-6^\circ/s \dots +6^\circ/s$					
drive	$\alpha = \int \left(\frac{d\alpha}{dt} \right) dt$					
	limit α to be $\geq 0^\circ$					

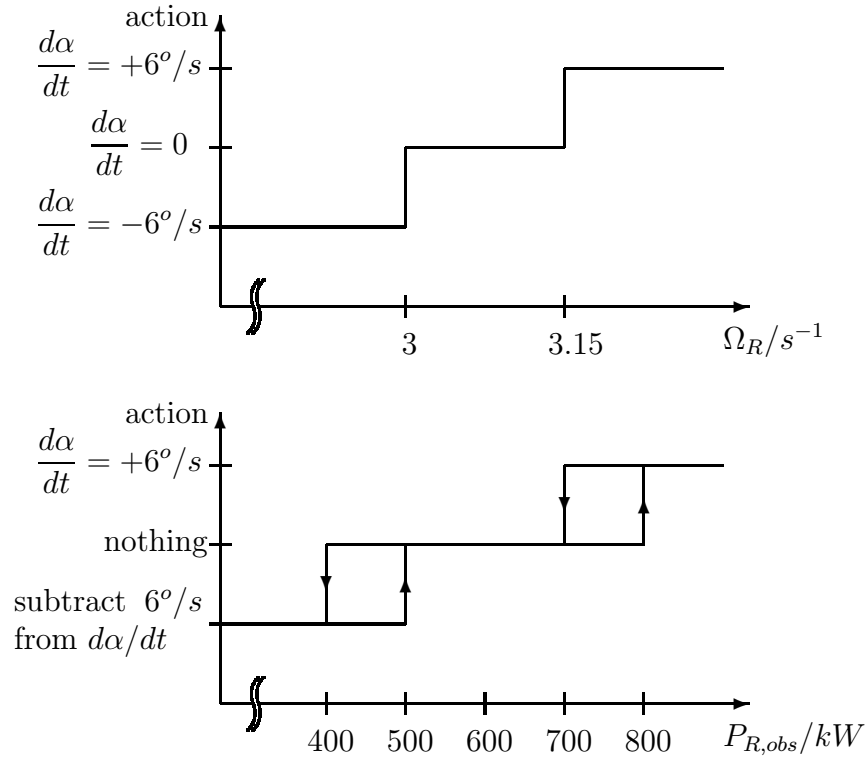

Figure 10: Illustration of the pitch angle controller described in table 7

constant C is $C = 26990 Nm s^2$. Together with the mechanical generator power of $P_{Gr} = 671 kW$, the rotor speed at which rated power is reached can be calculated and becomes $\Omega_{Rr} = 2.92 s^{-1}$. As the controller will dynamically leave its tolerance band, the lower limit of the tolerance band should be a bit above Ω_{Rr} , so that rated power will still be delivered even if the controller has to decrease the pitch angle. Therefore, the lower limit of the tolerance band was set to $3 s^{-1}$. Together with an assumed relative width of the tolerance band of 5% this leads to the upper limit of $3.15 s^{-1}$.

Unfortunately, this simple controller described so far is not sufficient. The reason is the following: When the wind turbine is running at partial load, quite below the rated values of power and rotor speed, and the wind speed increases rapidly during a sudden wind gust, the aerodynamic power P_R will increase rapidly. However, the controller will not do anything as the rotor speed is still low, even though increasing. Instead, it will wait until the rotor speed exceeds the tolerance band on the upper limit. At this time, depending on the strength of the wind gust, the rotor power may be quite above 1 MW. But even when the controller finally starts pitching the blades, due to the limited speed of the pitch drives it will take several seconds until it reaches the necessary pitch angle to reduce the power below its rated value. During this time, the rotor will accelerate further and in the beginning the rotor power can also still increase²⁶. Afterwards, it takes much time until the rotor slows down to the upper

²⁶The described scenario is not even the worst. If the wind gust is accelerating fast enough, it may

speed limit of the controller. As the power at higher pitch angles is very sensitive to changes in pitch angle, it will be decreased very much during this time. It is possible that it becomes even negative. The result is a very weakly dampened oscillation, which is excited again and again by the wind gusts.

The origin of this time delay as well as these oscillations is clear — it is the variable gain of the controlled system. While this gain is very low near a pitch angle of $\alpha = 0$, so that the first few degrees reduce the rotor power by almost nothing²⁷, it can become very large for high wind speeds and large pitch angles, so that a few degrees can mean the difference between rated power and zero power²⁸.

One obvious solution to this problem is the use of an adaptive controller. As mentioned above, this solution is rather complicated. Another drawback is that the adaption can only be realized by a reduction in controller gain for high wind speeds. The necessary increase in controller gain around rated wind speed cannot be achieved, as the limit here is the possible speed of the pitch drives, which shouldn't be increased to more than the value needed for the constant speed, pitch controlled concept.

Fortunately, another solution showed up which is depicted in the middle of table 7 and in the lower part of figure 10. It is based on the torque observer described in section 3.2.1. As mentioned above, from the observed rotor torque it is also possible to calculate the observed rotor power. This rotor power is an estimate for the derivative of the rotor speed and can therefore be used in an additional controller to stabilize the system²⁹. This additional controller will be described in the following.

In order not to risk a mechanical overloading of the wind turbine, the aerodynamic power should not exceed a certain value, regardless whether the wind turbine is already running fast enough to deliver its rated power to the grid or not. Therefore, if this power level (which is $800kW$ here) is exceeded, then the rotor blades should be pitched in order to reduce the power taken from the wind. On the other hand, if the rotor power falls below another certain power level (which is $400kW$ here) then the rotor power should not be reduced any more, as otherwise it is likely to be too small afterwards when the rotor speed descends below the tolerance band. Instead, it is better to wait, as with this small rotor power the rotor speed will definitely decrease.

The realization of these two conditions was achieved by using another three-level controller, this time including a hysteresis. The hysteresis was introduced here as it seemed to be better to keep this additional controller in action until the condition which led to its intervention has decreased to some extent. Then the control is handed

stall the rotor in partial load operation, which is not noticed by the controller. If the rotor is still stalled when the pitching action starts, then the power will first increase very fast when the angle of attack is reduced because the rotor comes out of the stall and produces its full power.

²⁷As mentioned in footnote 26, if the rotor was previously stalled they can even increase the rotor power. In this case the gain of the controlled system becomes negative!

²⁸As an example, reference [37] says that for the DEBRA-25 wind turbine operating at 2.8 times its rated wind speed pitching by an angle of 1.7° changes the rotor power from $0.4P_R$ to $1.6P_R$. Near rated wind speed, the same change in pitch angle would change the rotor power only from $0.95P_R$ to $1.05P_R$. Even though the DEBRA-25 is a two speed turbine, things are similar for variable speed turbines.

²⁹From a control system point of view it might be more straightforward to use the rotor torque instead of the rotor power for this additional controller as the rotor torque together with the generator torque is a measure of the derivative of the rotor speed. But as the rotor speed will be kept close to its rated value by a well designed controller, it is also possible to use rotor power which is more vivid.

back to the rotor speed controller. This additional controller is depicted in the middle of table 7 and in the lower diagram of figure 10.

One thing that should be given some attention is that $\frac{d\alpha}{dt}$ is set to $+6^\circ/s$ if the rotor power is too large, while the $6^\circ/s$ are only subtracted if the power is too low. The reason is that if the rotor power is too high this is a condition which might endanger the mechanical integrity of the wind turbine. Therefore, immediate action has to be taken to end the dangerous situation. If, on the other hand, the rotor power becomes too low, this is not dangerous. The only drawback of this condition is that energy might be lost if the rotor speed decreases too far. So no over-hasty reaction is necessary here, and it might also be sensible just to wait some time, because if the wind speed increases further things will correct themselves without action. Accordingly, $\frac{d\alpha}{dt}$ is only decreased by $6^\circ/s$, which simply moves the controller characteristic in the upper part of figure 10 down by this amount. This means that if the rotor speed is too high, then the blades simply keep their position until the rotor speed or the power changes.

Due to this subtraction, this time it is really necessary to limit $\frac{d\alpha}{dt}$ to the range of $-6^\circ/s \dots +6^\circ/s$, which is the assumed speed limit of the pitch drives.

As is shown in section 5, this additional controller works very well. The combination of the two controllers provide a very stable behaviour for any wind speed, and during transients the mechanical power acting on the turbine is always kept within sensible limits.

4 Modeling the wind turbine

In this section, the modeling of the different components will be described. However, it must be understood that it was not the aim of this project to establish complete models of the components. Only the behaviour which is necessary in order to calculate the power fed to the grid is modeled.

As an example for this simplified modeling, let's consider the gearbox, which is used in the single speed and two speed concepts.

In reality, it is the task of the gearbox to translate the mechanical power from the slow rotating rotor shaft to the fast rotating generator shaft. The behaviour of a gearbox is quite complex. For example, the gearbox has a finite rotational stiffness between its two shafts. This limited stiffness is a result of the elasticity of the material from which the gearwheels and shafts of the gearbox are made. Additionally, there is also a backlash between the teeth, which brings a nonlinear behaviour into the gearbox. Finally, the gearbox is very often itself rotatable and fixed with springs and dampers in order to dampen the torque fluctuations resulting from wind gusts and an insufficiently fast response from the control system.

If a complete model of the gearbox would be the target, then it would be necessary to model at least this whole behaviour. The result would then be a second order model, possibly with a damping smaller than unity and therefore with the possibility of oscillations, combined with the nonlinear model for the backlash. In consequence, this model would lead to the need of covering this whole behaviour in the controller design, as the controller must avoid to excite resonance frequencies of the system. So, this approach would lead to a very complex model.

However, if only the averaged power output is of interest, then the torsional oscillations due to an excitation of eigenfrequencies are not important, as the averaging of the power will lead to the same result as if the torque would have been averaged first and then transmitted via the gearbox. This leads to the question: Which characteristics of the gearbox have a more than negligible influence on the power output of the wind turbine? As was mentioned before, the dynamic properties don't.

So what about the speed translation? It is, of course, needed as long as the generator is modeled by its electro-mechanical equations. But these equations are mainly important if the interest lies on the behaviour during transients. If only the power output is of concern, than the generator is only a device which takes a certain amount of mechanical power from the rotor and delivers it in electrical quantities, whereby some power is transformed into heat, so that the efficiency is smaller than unity. So if the only interest is in power output, then the generator can be modeled simply as an efficiency factor which is applied to the mechanical input power³⁰. But if only the input power of the generator is of concern, it does not matter any more which speed the generator shaft has. So the speed translation of the gearbox is not needed any more, and the whole gearbox model collapses into another efficiency factor, which is of course dependent on the transmitted mechanical power and the speed of the shafts.

This process of simplifying the models was used throughout this work. For convenience, not all individual intermediate stages of simplification of all components will be described in this section, as some of the simplifications are highly dependent on

³⁰Of course this efficiency factor depends on the input power itself. See section 4.8 for details.

the simplification level of other components, as can be seen in the above example of gearbox and generator. Instead, only the final models will be described, and it will be discussed which properties of reality are left out and what the consequences might be.

These final models were then implemented in the PECSIM simulation environment. This is a simulation system which is developed at the Institute for Power Electronics and Control of Drives of Darmstadt University of Technology. Originally, it was intended for the simulation of power electronics (as also its full name “Power Electronics Circuit Simulation” indicates). However, as it also provides a fully developed system simulation capability and as it can be extended by use of macro facilities and, if necessary, even by FORTRAN-programming, it was used for these simulations. One feature of PECSIM is its very fast execution, which was very valuable in this work. For details on PECSIM, refer to [1, 3, 2].

4.1 Wind flow

The wind flow is for sure the part of the model which is simplified the most compared to reality. In reality, the wind flow is a three dimensional, time variant process. As the wind strokes over the rough surface that a landscape presents, the air is braked down. The lower the wind flows above the surface, the stronger the braking action is³¹. This leads to the well-known mathematical formulas for the wind speed as a function of height given for example in references [37, 15].

However, these formulas describe only the average value of the wind speed. But the surface has also an effect on the turbulence of the wind. If one imagines one “packet” of air which is braked only at the bottom, it is clear that it starts to rotate. The result is a vortex, and the sum of all the interacting vortices are the wind gusts that everyone knows.

Unfortunately, this means that a wind gust doesn’t just mean an increase in wind velocity. It is also coupled with changes in the directions in which the air particles flow. This whole process is of course non-stationary, and it is also limited in space and in time. Reference [37] mentions that the sizes of extreme wind gusts vary between $23m$ and $72m$. These small sizes mean also that it is possible that only a part of the rotor of a wind turbine is hit by a wind gust.

How can this complex process be modeled? First, it would be necessary to define the surface (or the “landscape”) near the simulated test site, and then a simulation model for boundary layers would be needed. This model would provide the wind data at any point and any time in the modeled space. The wind velocities and directions of all the points which lie in the rotor plane would then be entered into a three-dimensional rotor model. Such a model could be anything from a simple blade-element model (the simplest possible), where each blade element is calculated with a different velocity and angle of attack, up to complete three dimensional models based on vortices and including three dimensional effects of the rotor and the interaction of the rotor and its environment.

All these models suffer from two major drawbacks:

³¹Mathematically the wind speed approaches 0 as the height approaches 0.

- Simulation models for the boundary layer simulation are not really reliable and have problems with complex terrain [43].
- Both the boundary layer simulation and the three-dimensional rotor model are very computing-intensive. It may be possible to calculate them for short periods of time as a time-step simulation, but it is not possible to calculate the amounts of real time which were needed in this study of energy capture, at least not with desktop computing equipment like a PC or a workstation. It is well possible that supercomputers would be able to do the job, but their computing time is prohibitively expensive.

For these reasons, a much simpler model was developed. It consists of only one wind speed value at a time acting on the entire rotor. Wind gusts are only modeled as variations of the wind velocity. The changes in the azimuth angle of the wind were also neglected, because it was assumed that the angle tracking systems of all different control systems make errors of similar size, which also have similar effects on the energy capture. This reduces the wind model to the generation of one time characteristic, namely the wind speed, which will be described in the following.

The first idea that comes to one's mind when thinking of how to model the time characteristic of the wind would be to use measured time characteristics. Of course this would ensure the highest quality in wind data which is possible. However, it would mean to get measured time characteristics for all combinations of average wind speed and turbulence, which is very difficult, as long measurements (at least *5min* real time) are needed. Even in the large database described in reference [19] one cannot find all the combinations that were thought to be necessary for this work.

So the only possibility which remains is the artificial generation of the needed time characteristics. This can be done by using a fourier synthesis, as is shown for example in reference [52]. However, as the wind is a stochastic process, a time domain modeling based on random numbers was considered to be more appropriate.

Of course the generated time characteristic should still resemble the true wind regarding its characteristics like the rise time of wind gusts. One method of generating such time characteristics from sequences of gaussian distributed (pseudo) random numbers is given in reference [49]. This method was adopted and slightly modified in some respects.

The modified method will be described in the following with the help of table 8, which depicts it for the values of the n -th time interval. It generates the time characteristic of the wind speed from the given values (simulation parameters) of average wind speed \bar{v}_w and average wind power gradient $\overline{WPG}(\bar{v}_w)$.

First it was considered to calculate all the necessary wind speed data points before the simulation starts. However, a storage within the simulation program was not possible due to memory limitations of the simulation package used. Writing them to a file and reading them during the simulation was considered to be too much programming work. Therefore, an "on the fly" approach was chosen, where the next part of the wind speed time characteristic is generated when it is needed in the simulation, i.e. when the previous part of the time characteristic came to an end.

The generation of the wind speed is done in time steps. In each step, the wind speed at the end of the step is calculated. Later, this speed value is used as the beginning

Table 8: Algorithm for wind speed generation

	Wind speed	Wind power gradient
Random numbers	$R_{v,n,1..3} = \text{Rand}[-1, 1]$	$R_{WPG,n,1..3} = \text{Rand}[-1, 1]$
Average	$R_{v,n} = \frac{1}{3} \sum_{j=1}^3 R_{v,n,j}$	$R_{WPG,n} = \left \frac{1}{3} \sum_{j=1}^3 R_{WPG,n,j} \right $
Targets	$v_{w,n} = \bar{v}_w \cdot (1 + 0.0308c_{Turb}R_{v,n}) \cdot C$	$WPG_n = \overline{WPG}(\bar{v}_w) \cdot (1 + 7(R_{WPG,n} - 0.4)^3)$
Limit	limit $v_{w,n}$ to $[0.1 \frac{m}{s}, \infty)$	
Slope	$\left. \frac{\Delta v_w}{\Delta t} \right _n = WPG_n \cdot 2 \frac{v_{w,n} - v_{w,n-1}}{\rho (v_{w,n}^3 - v_{w,n-1}^3)}$	
Limit	limit $\left. \frac{\Delta v_w}{\Delta t} \right _n$ to $[0, 5 \frac{m}{s^2}]$	
Duration	$\Delta t_n = \left \frac{v_{w,n} - v_{w,n-1}}{\left. \frac{\Delta v_w}{\Delta t} \right _n} \right $	
End time	$t_n = t_{n-1} + \Delta t_n$	
Polynomial coefficients	$C_{n,2} = 3 \cdot \frac{v_{w,n} - v_{w,n-1}}{\Delta t_n^2}$	$C_{n,3} = -2 \cdot \frac{v_{w,n} - v_{w,n-1}}{\Delta t_n^3}$
Wind speed	$v_w = C_{n,3} \cdot (t - t_{n-1})^3 + C_{n,2} \cdot (t - t_{n-1})^2 + v_{w,n-1}$ for $t_{n-1} < t < t_n$	

wind speed of the next step³². However, these time steps are not identical with the time steps of the time step simulation. The latter are much smaller

The wind speed generation algorithm starts with a pseudo random number generator which creates random numbers in a scalable area. Reference [49] tells that two rows of random numbers are needed, which should both be gaussian distributed, one over the interval of $[-1, 1]$ and the other one over the interval $[0, 1]$. Unfortunately, the number generator used here provides only equally distributed numbers in the interval $[-1, 1]$. Therefore, some special treatment is necessary.

The gaussian distribution is approximated by averaging three numbers. According to [47], this results in an approximation of a gaussian distribution by parabolas about the interval $[-1, 1]$. This is a very pleasing characteristic, as an ideal gaussian distribution is not limited to an interval. So with a real gaussian distribution, very large wind speeds can be obtained (even though at very small probabilities), which are not observed in nature. Therefore, this limited approximation is well suited to the needs here.

For the wind power gradient, the absolute value is taken next. This does not alter the shape of the distribution in the positive half of the interval, but it simply doubles the probability density there. As a consequence, the distribution is now in the interval $[0, 1]$.

Now, the target values in terms of wind speed and wind power gradient are determined. The factor 0.0308 is an empirically gained factor which ensures the right turbulence level if the turbulence c_{Turb} is given in % (the turbulence intensity is defined as the standard deviation of the wind speed divided by the average wind speed). The factor C has a special function which will be explained later. Normally, this factor is $C = 1$. The calculation of the average wind power gradient $\overline{WPG}(\overline{v_w})$ as a function of average wind speed will also be discussed later. According to [49], the equation used to calculate the actual wind power gradient approximates a Rayleigh distribution for the wind power gradient, which is according to the same reference adequate for this purpose.

In the next step, the wind speed value is limited to values larger than $0.1m/s$. The reason for this lower limit is that the wind rotor model doesn't converge well for wind speeds very close to 0 (for 0 itself, it doesn't converge at all). As such small wind speeds are practically not important – for the energy capture it makes almost no difference whether the wind speed is $0.1m/s$ or 0 – they are not allowed here.

Next, the average slope of the time interval is calculated from the wind speed values at the beginning and at the end of the interval and the average wind power gradient. The formula used is given in reference [49] and can be derived as follows: The power inherent in the wind is

$$P_w = \frac{1}{2}\rho A v_w^3. \quad (18)$$

Normalized to the area we get:

$$\frac{P_w}{A} = \frac{1}{2}\rho v_w^3 \quad (19)$$

³²Logically, the question of the first wind speed value in a simulation arises. The chosen solution is to use the average wind speed for which the simulation is to be done as the starting wind speed.

The wind power gradient is defined as

$$WPG = \frac{d\left(\frac{P_w}{A}\right)}{dt} \quad (20)$$

and its average is

$$\overline{WPG} = \frac{\Delta\left(\frac{P_w}{A}\right)}{\Delta t}. \quad (21)$$

Writing the differences explicitly and inserting equation 19 gives for one interval:

$$\overline{WPG}_n = \frac{\frac{1}{2}\rho(v_{w,n}^3 - v_{w,n-1}^3)}{t_n - t_{n-1}} \quad (22)$$

On the other hand, the average slope of the wind speed which we want to calculate³³ is:

$$\frac{\Delta v_w}{\Delta t} = \frac{v_{w,n} - v_{w,n-1}}{t_n - t_{n-1}} \quad (23)$$

Setting the denominators of the equations 22 and 23 equal and solving the resulting equation for the wind speed slope gives the result in table 8.

The wind speed slope is then limited to the interval $[0, 5m/s^2]$. The reason for this limiting is that quite a few of the extreme wind gusts given in reference [37] have only slightly above $5m/s^2$ slope. Therefore, all wind gusts with a higher wind speed acceleration can be classified as very rare extreme wind gusts. However, a comparison of energy captures should probably not include phenomena which occur only on very rare occasions. So the slope is limited to a value just below the extreme wind gusts³⁴.

Now the duration of the time interval is calculated from the difference between the wind speed at the end and at the beginning of the time interval and the average slope. The wind speed at the end of the interval may also be lower than the wind speed at the beginning of the interval, while the slope is always positive. As the resulting time difference has to be positive (because the time interval must always extend into the future), the absolute value has to be taken.

Then the end time of the interval is calculated from the start time and the duration of the interval.

Now the start and end values of both time and wind speed are known. Because the wind speed has to be steady, a transition function between the two discrete values is needed. A linear transition doesn't seem to be adequate, as the quantities of flow processes in nature are usually not only steady, but also differentiable, which a polygon-shaped linear interpolation would not be. The logical choice would now be to use a spline function. However, the problem with using a spline function is that *all* data points have to be known in order to calculate the spline coefficients.

³³Of course the needed time difference could also be calculated from equation 22 directly. However, this would not allow limiting of the wind speed slope. Therefore, the approach which is detailed here was selected.

³⁴It should be noted that such extreme wind gusts are of special importance when designing the controllers for real wind turbines, as the controllers must be able to handle such extreme wind gusts safely.

To solve this problem for knowledge of the “future”, another condition is needed. The condition chosen here is that the tangent on the wind speed time characteristic at the beginning and at the end of each interval is horizontal. This condition doesn’t seem to do much harm to the time characteristic, and it simplifies the calculation of the time characteristic very much.

The real interpolation is then done by using a third-order polynomial as in reference [49]. The coefficients of this polynomial are found using the formulas given in table 8. The derivation of these equations is described in appendix 9.1.

The last line of the table gives the calculation of the interpolated wind speed as it is done during the simulation as long as the simulation time is within the time interval. If the simulation time exceeds the time interval, the process of table 8 is initiated again for the next time interval.

The wind speed generated in this way is considered to be the free wind speed in the rotor plane if the wind turbine would not be there. This consideration makes it the right input for the rotor model described in the next section. However, for the purpose of realizing the wind speed observer described in [22], a model of the tower shadow or tower build-up was necessary³⁵.

In reality, the tower effect decreases the wind speed of only one rotor blade, while the other blades (those not in front of the tower) are not affected by it. Unfortunately, in a model comprising only one wind speed value for the whole rotor this effect cannot be represented properly. Therefore, a very simplistic model is used, which consists in a triangular decrease in the overall wind speed by 5% whenever a rotor blade crosses in front of the tower.

Now the factor C in the line “targets” of table 8 needs some explanation. One problem with this wind speed model is that after the minimum simulated time (which is $5min$ for each of the energy capture simulations) has passed, it cannot be ensured that the average wind speed has the value which entered the calculations as \bar{v}_w because of the pseudo-random nature of the wind speed generation. To overcome this problem, the actual average wind speed is determined by integrating the actual wind speed and dividing by the simulated time which has already passed. After the minimum simulated time is over, this “measured” average wind speed is compared to its reference \bar{v}_w . If the simulation produced an average wind speed which is too small, then the factor C is set to 1.1 and the simulation is continued until the “measured” average wind speed is correct. In the opposite case, C is set to 0.9.

Finally, it must be explained how the average wind power gradient $\overline{WPG}(\bar{v}_w)$ is calculated as a function of \bar{v}_w . Reference [49] provides the following formula for this relation:

$$\overline{WPG}(\bar{v}_w) = 1 \frac{W}{m^2s} \cdot 10^{\frac{1-\frac{s}{m} \cdot \bar{v}_w + 1}{c_{WPG}}} \quad (24)$$

Reference [49] also claims that a parameter of $c_{WPG} = 5.5$ is well suited for the conditions at Esbjerg (a city on the west coast of Denmark), while lower values of

³⁵The wind speed observer was not simulated during the simulation runs for calculation of energy capture. Instead, the generated wind speed was fed directly into the power controller of the stall controlled variable speed system described in section 3.2.1. However, the tower shadow model developed before was left in the simulation.

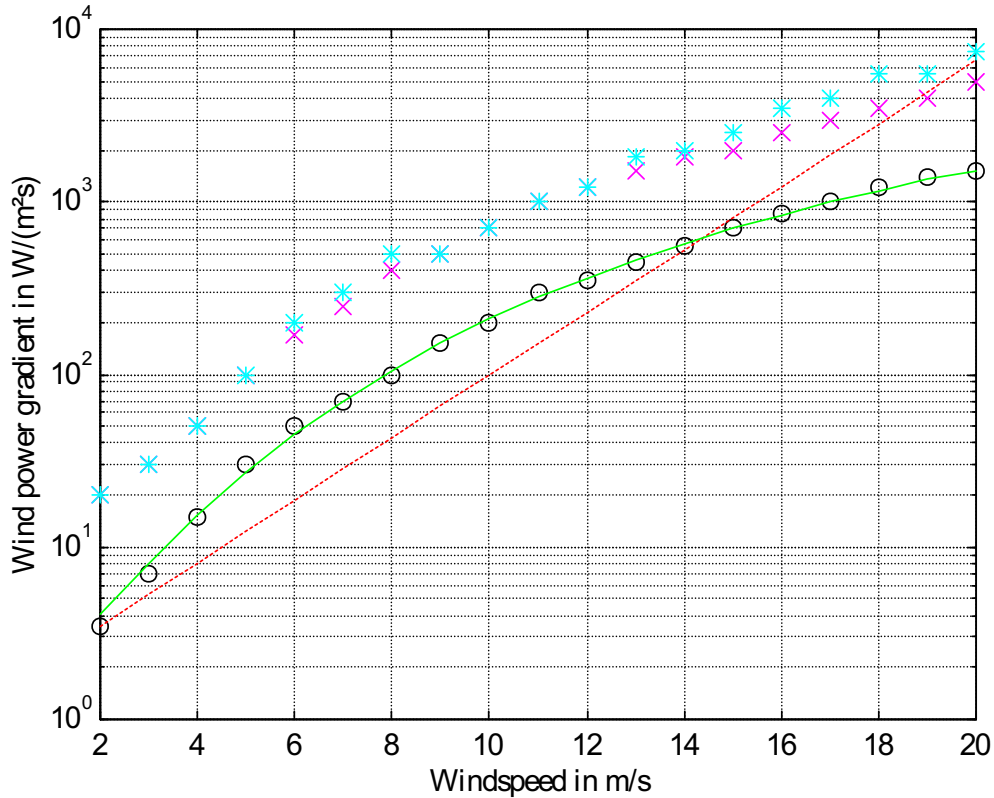

Figure 11: Finding a formula for the wind power gradient (logarithmic scale): Circles denote mean values, crosses denote the 99.9% values, stars are the maximum wind power gradients measured at this or a lower average wind speed, the dashed line is the formula given in [49], and the solid line is the new formula mentioned in the text.

c_{WPG} will lead to more rapid changes and larger values will lead to slower changes. However, in [49] a figure with measured values of the wind power gradient is presented which seems to be the same as a figure in reference [37], and reference [37] says that “the measurements for this figure were at the west coast of Denmark”. The measured values read from these figures are presented in figure 11 together with the values calculated from the formula given in reference [49].

It can be seen that the results from the formula from [49] (dashed line) are only for two rather narrow wind speed regions close to the measured mean values (circles), namely in the case of very low and medium wind speeds. For moderately low wind speeds the formula gives values which are too small. But what is even more problematic is that for very high wind speeds the values from the formula are becoming much too large. They become even larger than the 99.9% values (crosses). This means that the formula leads to wind speed changes which are much more rapid than in reality, which in consequence can lead to wrong dynamic results, if controllers or the rotor speed itself are unable to follow these too rapid changes. What makes this problem worse is that in order to calculate the energy capture wind speeds of up to 25m/s have to be used, as most wind turbines cut out at this wind speed. As the figure in references

[37, 49] gives measured values only for wind speeds of up to 20m/s , this means that extrapolation is needed here. However, the increasing difference between the measured and the calculated results from this formula in figure 11 doesn't look very promising for extrapolating.

But even if this difference doesn't look too harmful on the logarithmic scale of figure 11, things look much worse if a linear scale is used for the wind power gradient, as in figure 12. Here, it is clear that this formula cannot be used for extrapolation.

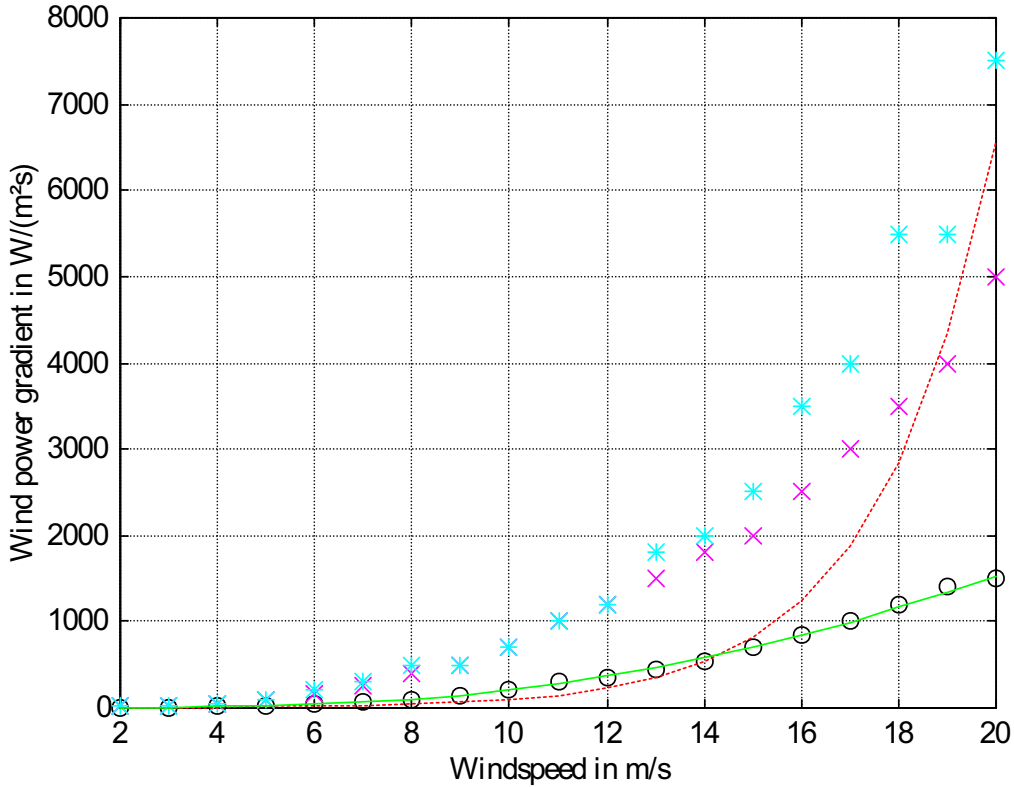

Figure 12: Finding a formula for the wind power gradient (linear scale): Circles denote mean values, crosses denote the 99.9% values, stars are the maximum wind power gradients measured at this or a lower mean wind speed, the dashed line is the formula given in [49], and the solid line is the new formula mentioned in the text.

For this reason, the formula was extended so that it fitted the measured mean values better. The resulting new formula is:

$$\overline{WPG}(\bar{v}_w) = 1 \frac{W}{m^2 s} \cdot 10^{4.47 \frac{\left(\frac{v_w}{1m/s}\right)^{1.2}}{\left(\frac{v_w}{1m/s}\right)^{1.2} + 14.7}} \quad (25)$$

As can be seen in both figures 11 and 12, the new formula (which is shown by the solid line) approximates the mean values much better than the old one, so that even

the extrapolation for wind speeds of up to 25m/s can be done with a clean conscience.

Some exemplary time characteristics of this whole wind speed model can be seen in the time characteristics in section 5.

4.2 Wind turbine rotor

Before the details of the wind turbine rotor will be discussed, it should be recalled that it is assumed that the azimuth angle tracking (the so called yawing mechanism) works without errors, so that the wind speed vector is always perpendicular to the rotor plane. This eliminates the need to model the azimuth angle tracking system.

The wind turbine rotor is modeled by a blade element model as described in [15]. In this model, each rotor blade (only one is considered here and multiplied by the number of blades later on, as there is only one wind speed value for the whole rotor) is divided into a number of sections, which are called blade elements and treated one after the other. For each blade element, the model basically combines the equations for lift based on the characteristics of the aerodynamic profile and on the impulse conservation in order to find the actual angle of attack. After the angle of attack is found, the aerodynamic forces (lift and drag) can be calculated. Finally, the aerodynamic forces of all elements are added over the whole blade in order to find the resulting forces.

According to [15], corrections for small and large tip speed ratios are applied. However, the blade element model is only a static model which neglects several effects found on real wind turbines. These include the tip effect (vortices are generated at the blade tips which draw energy from the rotor), the dynamic effects (like dynamic stall) and the three-dimensional effects, although some models for these effects are published in [44, 38, 7, 12, 41]. The problem with these published models is mainly that if formulas are provided then the proportionality and time constants are not given or that the models require a three dimensional computation of the wind field.

The inaccuracy introduced by these simplifications was thought to be acceptable, as only a comparison of energy capture and not the maximum precision for the individual values was the aim. This simplification will cause the power coefficient c_P to be too large, as mainly losses are neglected.

Another reason for not using a more complex model is the needed computation time. Even the described blade element model proved to be too complex for a time step simulation, as it requires solving 50 aerodynamical equations (for the 50 blade elements) within each time step. As the aerodynamical equations cannot be solved analytically, solving each of them requires an iteration. On the other hand, extensive iterations within time steps generally lead to slow simulation models.

Therefore, before a simulation was started, this model was used to calculate the power coefficient c_P as a function of the tip speed ration λ and the pitch angle α for a number of different values of α and λ . The values of c_p gained during these computations were then stored in a two-dimensional array. In the simulation, λ is calculated from the actual values of rotor speed and wind speed according to:

$$\lambda = \frac{\Omega_R r_R}{v_w} \quad (26)$$

In the next step, c_p is found by using a linear interpolation between the values stored in the two-dimensional array using λ and the pitch angle α , which is known from the

pitch controller. So this array is used to compute c_p as a function of two parameters:

$$c_p = c_p(\lambda, \alpha) \quad (27)$$

Then, the rotor power is found from the basic equation of the wind turbine

$$P_R = \frac{1}{2} \rho A_R v_w^3 c_P, \quad (28)$$

and finally the rotor torque can be calculated:

$$T_R = \frac{P_R}{\Omega_R} \quad (29)$$

In the following, the blade element model will not be discussed in detail, as it was taken from reference [15] without any modifications. However, some diagrams of the rotor profiles and the results of the rotor model will be given. All aerodynamic profile data is taken from [46].

While real wind turbine rotors use different aerodynamic profiles at the individual radii, this characteristic was left out in the model and one profile was used for the entire blade. The reason was that between the radii at which the individual profiles are used, intermediate profiles are formed by interpolation. For these intermediate profiles no data from aerodynamic measurements is available. As this data would be needed to calculate the blade element model, the only possibility was to avoid the intermediate profiles by using a single profile for each rotor blade.

Figure 13 shows the most interesting characteristics of the profile which was used for most of the simulations (Goettingen Goe 758). The parameters shown c_l and c_d are the lift and drag coefficients, which are defined by the following equations [46]:

$$L = \frac{1}{2} \rho v^2 A c_l \quad (30)$$

$$D = \frac{1}{2} \rho v^2 A c_d \quad (31)$$

In these equations L is the lift produced by an airfoil of the area A being blown at with an apparent wind speed v , while D is its drag. Solved for the coefficients, these equations become:

$$c_l = \frac{L}{\frac{1}{2} \rho v^2 A} \quad (32)$$

$$c_d = \frac{D}{\frac{1}{2} \rho v^2 A} \quad (33)$$

As the characteristics of the profiles are normally given only for the rather small band of angles of attack which are of interest for aircraft, the characteristics were extended for higher angles of attack (which might occur in stalled wind turbine rotors). This was done by using the profile data for the flat plate for all angles of 30° and higher, as [46] tells that the exact geometry is of lower importance in this deep-stall region,

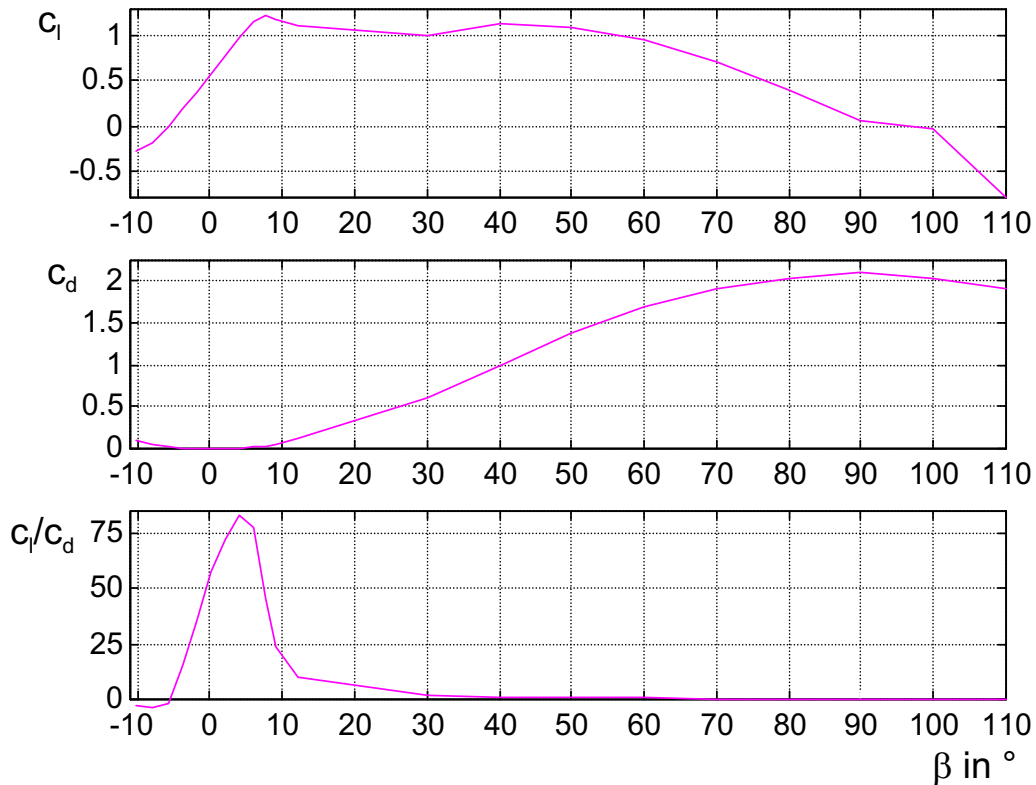

Figure 13: Lift coefficient c_l , drag coefficient c_d and glide ratio $\frac{c_l}{c_d}$ for the Goe 758 profile over the full interval of angles of attack

and as the data for the flat plate was available in [46] for the full range of angles of attack.

It can be clearly seen that the glide ratio (which is the ratio of lift to drag) is high only for a small range of angles of attack. As the glide ratio is a measure for the efficiency of the rotor blade, it can be concluded that the rotor blade is efficient only within this small range. However, this is not a disadvantage for the usage in wind turbines, as the blade should not be efficient at wind speeds above rated wind speed. This can be easily achieved by simply stalling the blade, which means to increase the angle of attack.

The characteristic of the profile within the range of angles of attack which are mainly of interest is shown in figure 14 together with the characteristics of the other two profiles which were used in this study.

The figure shows that the profiles are different in the angle of attack where they produce no lift. However, this can be compensated by simply turning the blades to a different design pitch angle.

What is of much greater importance is the difference between the angle of attack where the lift coefficient has its maximum (which is about the point where stall happens) and the point where the glide ratio has its largest value (which is the point where the profile should be used in order to gain the highest possible efficiency). The smaller

this distance is, the closer lie the wind speed of highest power coefficient and the wind speed of highest rotor power together.

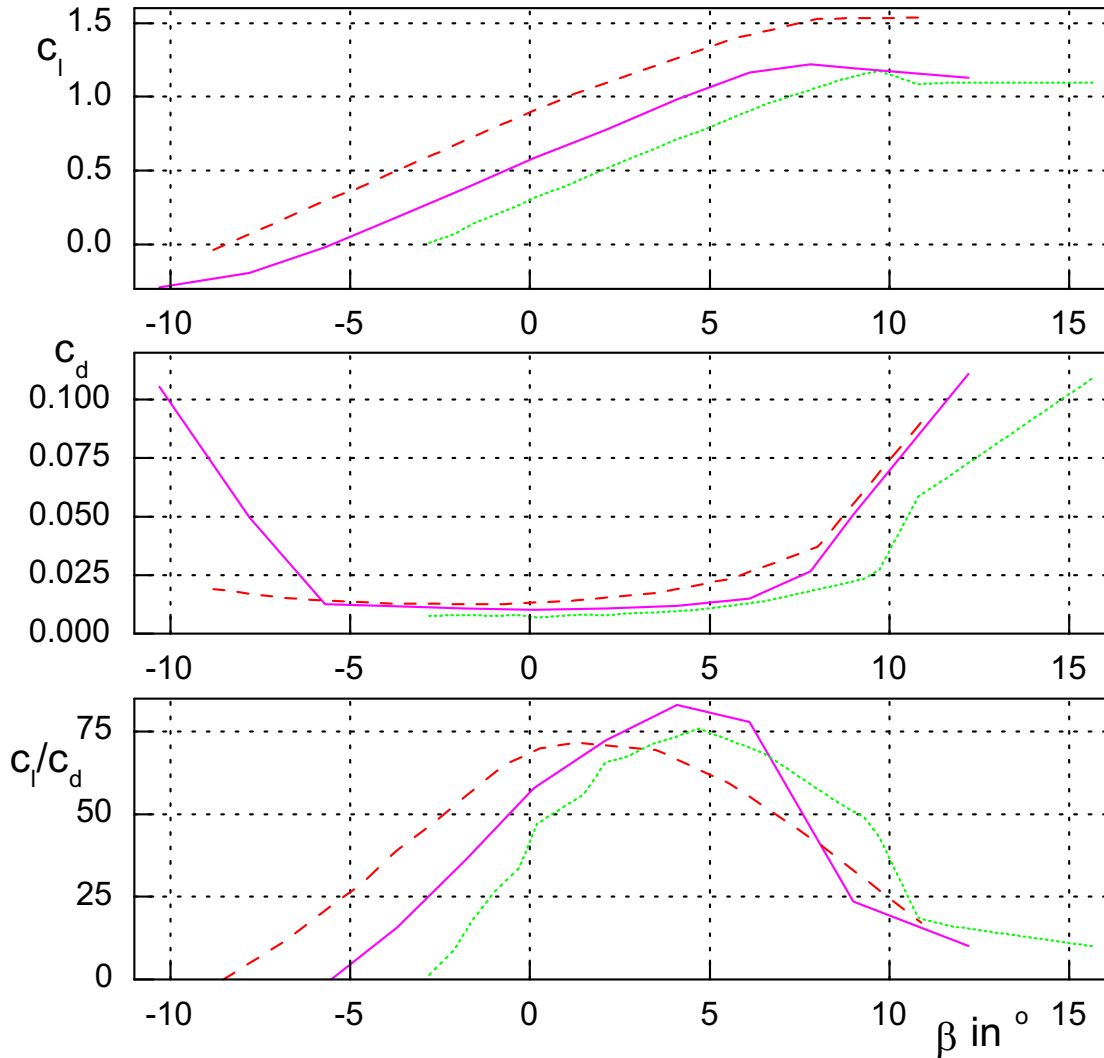

Figure 14: Lift coefficient c_l , drag coefficient c_d and glide ratio $\frac{c_l}{c_d}$ for the profiles Goe 758 (solid), Goe 535 (dashed) and Goe 771 (dotted) for the most interesting angles of attack. *Note:* The design points of the rotors for the simulations are always the points where the glide ratio $\frac{c_l}{c_d}$ is largest.

This difference in angle of attack is about 4° (from 8° to 4°) for the profile Goe 758, which is a quite low value. Therefore, the profile Goe 758 will be called a profile with a “sharp stall characteristic”. This stall characteristic is especially well suited for the variable speed, stall controlled concept.

In contrast, the profile Goe 535 has a difference between these two points of about 7° (from 8° to 1°). Therefore, it will be called a profile with a “broad stall characteristic”. It can be concluded that the difference in wind speeds between the maximum output power of the rotor (where stall occurs) and the maximum power coefficient is much larger for this profile than for the former. As for fixed speed systems the wind speed at

which rated power is delivered is roughly the same for both profiles, the wind speed at which the rotor has its highest efficiency will be much lower for the latter profile. As a lower wind speed also leads to a lower power, this means that the point of highest power coefficient will be quite different for these two profiles in terms of rotor power, which will result in a different partial load behaviour.

The profile Goe 771 has a difference of 5° and therefore lies in between the two extreme profiles.

This difference between the three profiles can also be seen in figure 15, which shows the profile polars. This means that the lift coefficient is plotted over the drag coefficient.

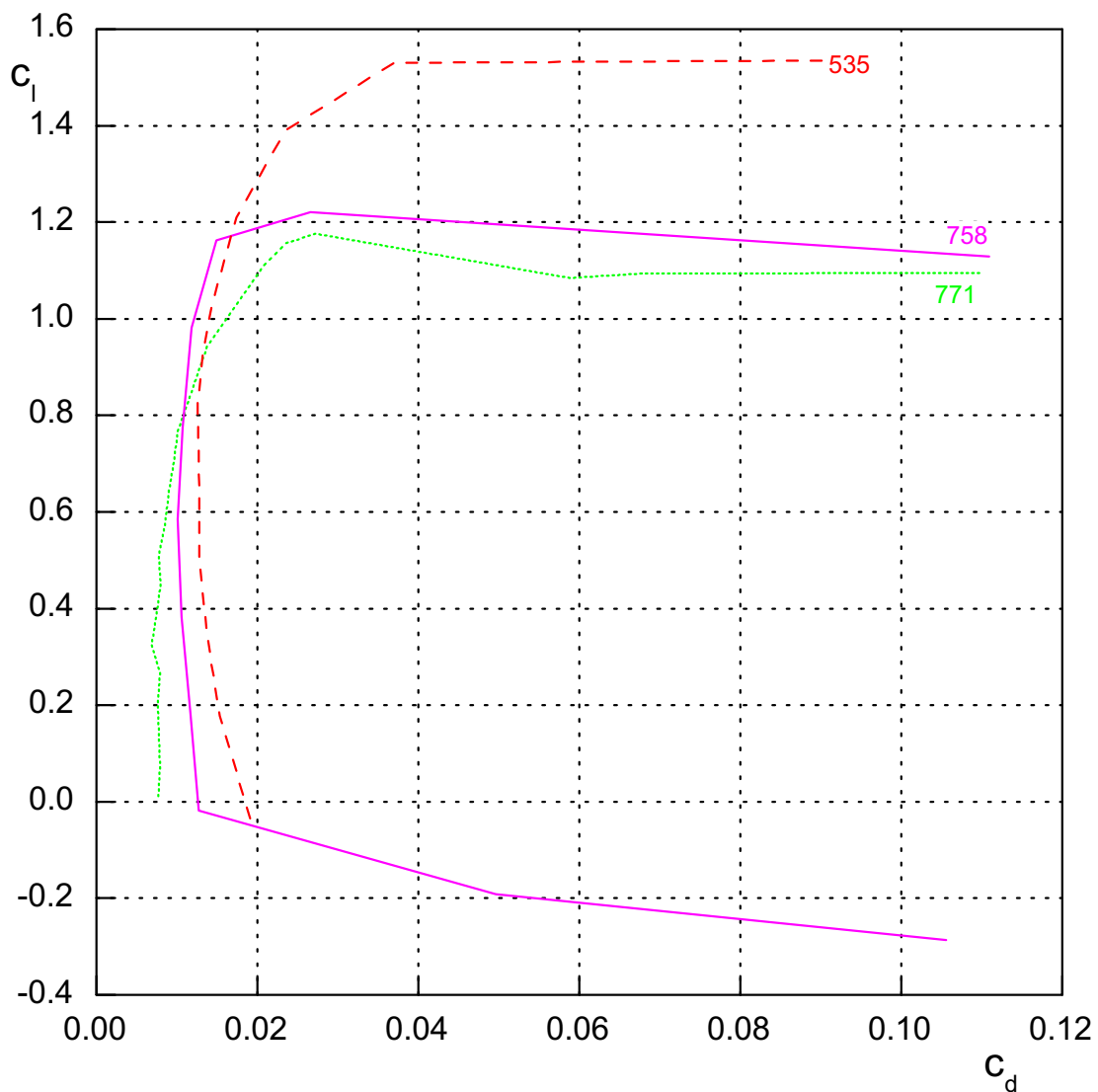

Figure 15: Profile polars for the profiles Goe 758 (solid), Goe 535 (dashed) and Goe 771 (dotted)

The profile Goe 758 with the sharp stall characteristic shows in this figure a very sudden change in the direction of the polar when stall occurs. It is almost a corner. For the intermediate profile Goe 771 this transition is already much smoother, while it

is very round for the profile with the broad stall characteristic.

Although these profiles do not belong to a systematic profile family, where the geometrical dimensions are related using a formula, it can be concluded from the figures that the three profiles have characteristics which place them logically in a line, with Goe 758 and Goe 535 forming the extremes and Goe 771 in between.

As mentioned above, the profile data shown in the preceding graphs is used to calculate the power coefficient as a function of pitch angle and tip speed ratio. One example of such a rotor characteristic is shown in figure 16 (a similar one is given in reference [10]). This figure shows only the most interesting part of the characteristic, as the whole characteristic needs to cover a pitch angle range from -10° up to $+60^\circ$ and tip speed ratios from near 0 up to 100 in order to cover also very extreme situations, which may occur for short times intervals.

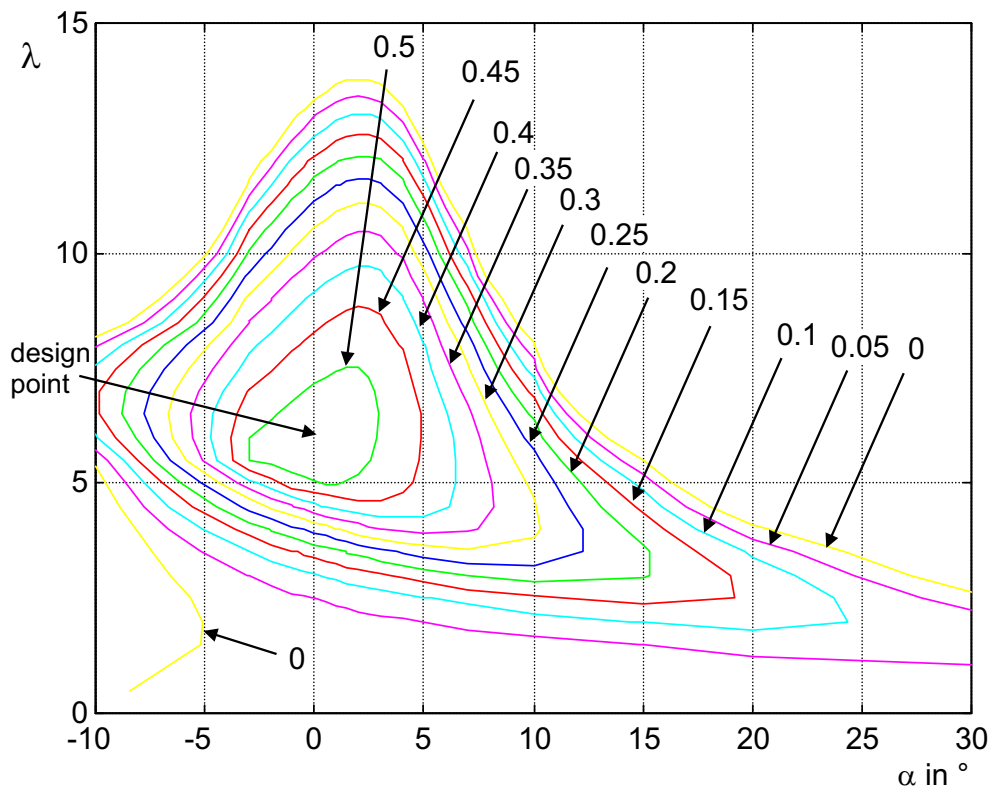

Figure 16: Exemplary rotor characteristic for the aerodynamic profile Goe 758 and a design tip speed ratio of 6. Shown are lines of equal c_p as a function of pitch angle α and actual tip speed ratio λ .

The figure shows clearly that only for pitch angles around 0 high power coefficients are reached. However, for larger pitch angle deviations there is not only a decrease in the maximum power coefficient which can be obtained, but also the band of tip speed ratios in which the power coefficient is positive becomes the narrower the farther one pitches the blades.

For combinations of tip speed ratios and pitch angles where the power coefficient is not positive, the lines have been omitted in the figure, as the power coefficient drops very quickly to very large negative numbers.

Figure 16 also gives the possibility to explain how the characteristic of optimum pitch angle versus actual tip speed ratio is gained, which is needed in the pitch controllers of the constant speed concepts. In order to produce this characteristic, it is necessary to find the pitch angle at which the power coefficient becomes maximum for each given tip speed ratio. In the figure, this is equivalent of finding a line connecting the uppermost points of all lines of equal power coefficient for tip speed ratios $\lambda > 6$ and continuing by connecting the lowest points of the lines for smaller tip speed ratios.

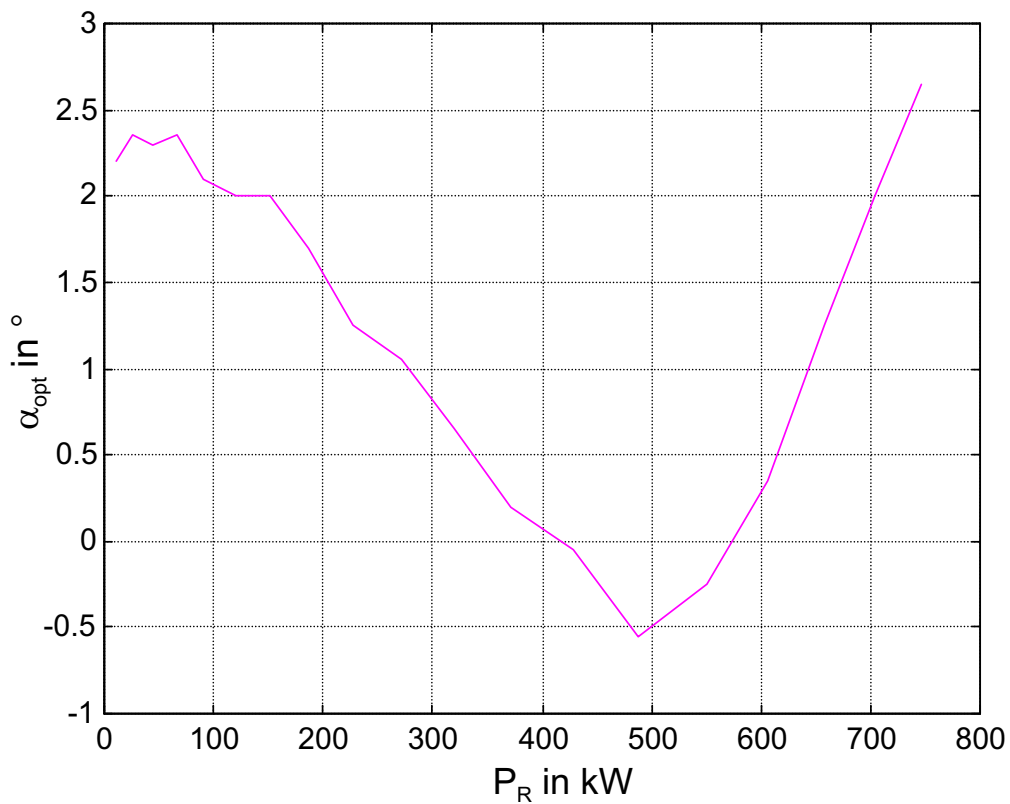

Figure 17: Example of the characteristic used for the determination of the optimum pitch angle α_{opt} below rated wind speed. Rotor with profile Goe 758 and design tip speed ratio of 6.

Such a line was calculated for the rotor speed at which the single speed wind turbines operate and is displayed in figure 17. As for a fixed rotor speed each tip speed ratio corresponds to one wind speed and therefore also to one value of power, figure 17 was not plotted above power coefficient but above power directly, as this is much easier to work with in the controller. The noise seen in the curve comes from the limited resolution of 0.05° of this iterative calculation. In spite of this, the general characteristic resembles the one found when connecting the above mentioned points

in figure 16. The increase on the right side can also be explained by the necessity to avoid the large angles of attack belonging to stall by turning the blades to a larger pitch angle.

4.3 Gearbox

In the real wind turbines using asynchronous generators, the gearbox has the task to transfer the mechanical power from the slow rotating rotor shaft to a fast rotating shaft which drives the generator³⁶. The need for this transmission arises from the problem that an asynchronous generator cannot be built for very low speeds with good efficiency [18]³⁷.

However, as mentioned before in the simulation the gearbox doesn't need to be modeled, because the generator torque can simply be transferred to the low speed shaft by a multiplication. Therefore, the remainder of the gearbox in the simulation is only its efficiency, which will be described in section 4.8.

The variable speed systems with their direct driven synchronous generators do not need gearboxes, so the gearbox losses are left out for these concepts.

4.4 Generator

Like the gearbox, the generator is modeled in the very primitive manner that it is only an efficiency, which is of course different for the synchronous and the asynchronous generators.

For the variable speed systems, the reference torque created by the torque controller is taken as the mechanical torque acting on the drive shaft without any delay. The reason for this is that the time constants of the power converter and the generator are so small when compared to the mechanical time constant of the rotor that they can be neglected. As for the efficiency, a permanent-magnet excited machine is chosen, as it gives the highest possible efficiency by dropping the excitation losses.

For the single speed and two speed systems, the generator torque is simply set equal to the rotor torque, which ensures that the rotor speed remains constant. This means that the slip of the asynchronous generator is neglected here. As this slip is very small, this is thought to be adequate for energy capture calculations.

However, it should be noted here that these models are not adequate for dynamic studies, where not only the slip, but also the torsional elasticity of the shafts and maybe the elasticity of the gearbox suspension needs to be modeled.

4.5 Power converter

The power converter is modeled only as an efficiency, too. Of course this efficiency is only applied to the variable speed systems, as the constant speed systems do not include a power converter.

³⁶1500rpm is a usual value for the speed of the fast shaft.

³⁷The bad efficiency results from a very poor power factor which such generators would have.

4.6 Transformer

The transformer needed to adapt the low voltage of the generator or power converter to the grid voltage (which is mostly medium voltage) is not modeled at all, as its efficiency is thought to be the same for all concepts under consideration.

4.7 Controller

The controller models are described in section 3.

4.8 Losses

The low voltage terminals of the transformer are taken as the reference point for energy comparison. Therefore, the energy losses between the rotor and the transformer terminals have to be modeled.

In order to model the losses of the different concepts, it is not sufficient to know the rated efficiency of all components. The reason for this is that wind turbines operate most of their time at partial load, where the efficiency of the components is usually much lower than at rated power. Therefore, a loss model is needed which takes the actual power into account. Such a model is presented in [17]. It is based on dividing the overall losses into the losses in individual components. For each of these individual losses the quantitative loss at rated power and its qualitative dependence on power, torque, rotor speed and other characteristics are given in [17]. A short summary of these losses is given in table 9. If no such proportionality is given for a loss, then this means that this loss is constant regardless of the power which is produced.

It can be seen that all variable losses depend on the three quantities power P , current I and rotational speed n . Two of these, namely the power and the speed, are already known from the mechanical equations of the rotor model. In contrast, the current I is not yet known. Fortunately, the current is not needed as a number, but it is sufficient to get a quantity proportional to the current. This is done in the following ways:

In the systems with the asynchronous generator, it is assumed that the power factor is constant. While this is not really true for an asynchronous generator, it can be used as a first, rough approximation. Under this condition, the current becomes proportional to the power.

For the systems with the synchronous generator, things are a bit more complicated, because the speed is also time variant. First, it is assumed that the power factor is constant. Under this assumption, the current is proportional to the generator torque, which can finally be expressed as the ratio between power and speed.³⁹

When all these relations are used, it is possible to write all losses as functions of power and speed. They must be adjusted so that they reach the values given in table 9 at rated power. Finally, all the losses which obey the same law can be condensed

³⁹This is not really true for the current in the inverter, as the grid voltage is constant and therefore the current should be proportional to the power rather than to the torque. Unfortunately, this mistake was not discovered until all the simulations were done. But the wrong values were kept as it is quite a lot of work to redo all the simulations while otherwise the deviation between the right and the used efficiency values is much smaller than the calibration accuracy described in section 4.9.

Table 9: Individual losses according to [17]

Component	Loss name	Asynchronous generator (1 or 2 constant speeds)		Synchronous generator (variable speed)	
		Full load loss in % of P_r	Proportional to	Full load loss in % of P_r	Proportional to
Gearbox	Gear mesh losses	1.7	P		
	Friction, windage and oil churning losses	1.0			
Generator	Copper and additional losses	1.5	I^2	3.5^{38}	I^2
	Core losses	1.5		1.2	n
	Friction, windage and cooling losses	0.5		1.0	n
Power Converter	Voltage drop of diodes			0.4	I
	Rectifier and inductor resistive losses			0.2	I^2
	Step-up converter transistor losses			0.75	I
	Step-up converter diode losses			0.25	I
	No load losses			0.1	
	Inverter load losses			1.5	I
	Inverter resistive losses			0.3	I^2

³⁸The higher losses of the synchronous generator are a result from the much larger copper mass of the low-speed design.

together. The result is one loss equation for each of the two groups of concepts. First, for the single speed and two speed concepts the power loss becomes:

$$P_L = 0.03P_r + 0.017P + 0.015\frac{P^2}{P_r} \quad (34)$$

For the variable speed concept, the power loss is:

$$P_L = 0.001P_r + 0.022P_r\frac{n}{n_r} + 0.029P\frac{n_r}{n} + 0.04\frac{P^2}{P_r}\frac{n_r^2}{n^2} \quad (35)$$

As mentioned in [17], from these equations it can be seen that the losses at rated power are higher for the variable speed concepts (9.2%) when compared to the other concepts (6.2%). For the no load losses, things are vice versa: The losses for the variable speed concepts are only 0.1%, while they are 3% for the other concepts. As shown in [17] it can be seen that the average efficiency of the variable speed concepts will be higher if the wind turbine is operated at a lower wind speed site, where it operates at low power most of the time, while it will be the opposite for a high wind speed site.

Reference [17] also shows how sensitive the results are to variations in the parameters of these loss equations.

However, there is also one part of the losses which is neglected completely in this study. These are the losses due to the energy consumed in the pitch drives when turning the rotor blades in the active stall and pitch controlled concepts. The reason for neglecting these losses is double.

On the one hand, no information was found on how much energy is really consumed in the pitch drives, so that no loss model could be established.

On the other hand, the pitch drives are mainly used for two different things: At low speed, they can be used to turn the blades to the optimum pitch angle for the actual wind speed. The energy used in the pitch drives is in reality taken from the energy fed to the grid. However, the turn angles required for this optimization are very small (as will be shown in figure 24). Therefore, also the amount of energy used for this optimization will not be too large. Things are much different when limiting power at high wind speeds. Here, large pitch angles are required by the pitch controlled concepts, which will cost more energy. However, at these wind speeds there is more than enough energy in the wind, so that the loss in the pitch drives could be compensated by designing the generator for a slightly higher power level and adjusting the setpoint of the power controller so that this higher power will be generated. The only problem is turning the blades back to normal position when the wind speed is decreasing. Here, a loss of energy may occur due to pitching, but as these time intervals are very short, not much energy will be lost. For these reasons, the energy lost in pitching was not included in the loss model.

4.9 Calibration

Before the simulations of the energy gain of the different concepts were done, all the simulations were calibrated in order to give comparable results. The goal of the calibration process was that all wind turbines should give the same maximum of the average

power over one simulation under turbulent conditions, which means that their power curves under turbulent conditions will reach the same maximum.⁴⁰

As [42] mentions, the highest turbulence allowed in power curve measurements is 15%. Therefore, it was assumed that the average turbulence in such measurements is somewhat below. As the next lower value for which simulations are done is 10%, this turbulence level was chosen for the calibration.

So after each alteration of parameters which influence the maximum average power (the highest bar in the uppermost diagram of figure 19), simulations were done and adjustments were made until the maximum of the average power for 10% turbulence was between $600kW$ and $606kW$. This means that the calibration accuracy is roughly 1%, and that all results may suffer from inaccuracies of at least this size.

The adjustments were done using different parameters, according to the possibilities of the different concepts. For the stall controlled concepts, the rotor speed was adjusted, which means in reality a change in the gearbox transmission ratio. The other concepts can be adjusted much easier by simply changing the reference power in their power controllers (the whole tolerance bands of the controllers must be shifted, of course).

The rotor speed (or the gearbox ratio) of the other concepts with asynchronous generator was set equal to the rotor speed of the passive stall controlled concepts.

4.10 Calculation of the annual energy capture

After the simulation model has been explained, the remaining question is how the annual energy capture is calculated from the results of the simulation.

When the simulation has finished, the average wind speed during the simulated time interval is equal to its reference value⁴¹. The time characteristic of the output power of the turbine is also known. By calculating the average of the output power over the whole simulated time, the average output power for this average wind speed is found⁴².

Next, this process is repeated for all wind speeds within the operation range of the wind turbine. As to the authors knowledge there is no wind turbine of usual size with a cut-in wind speed below $2m/s$ on the market (there is none mentioned in reference [14]), this was taken as the lowest wind speed in the simulation. The cut-out wind speed of most wind turbines is $25m/s$ [14], so this was taken as the upper limit. The next decision was upon the division of this area. While according to reference [42] real power curve measurements require data points separated by $0.5m/s$, this was thought to be too much in terms of needed simulation time. Therefore, one simulation each $1m/s$ was chosen. This means that the first simulation is performed for an average wind speed of $\bar{v}_w = 2.5m/s$, the next one for $\bar{v}_w = 3.5m/s$ and so on, until the last one with $\bar{v}_w = 24.5m/s$ is done.

⁴⁰As [14] shows, many of the passive stall controlled concepts are not adjusted like this in reality. Instead, their power curves reach much higher values than their rated power (up to 13% more in one case). For this study, it was decided that a fair comparison needs a common basis, and that a turbine giving e.g. 10% more power simply belongs into another power class.

⁴¹As explained in section 4.1, this is a condition for the end of the simulation.

⁴²This calculation is actually done all the time during the simulation and is simply stopped when the simulation is terminated. However, this doesn't have any influence on the results.

If the resulting average power of a simulation is below 0 (as it happens with fixed speed systems at low wind speeds), it is set to 0 because it is assumed that the wind turbine controller would notice that something is going wrong and would close down the turbine under such conditions (if the controller didn't simply know the real cut-in speed of its turbine).

After all these simulations are done, the average output power is known as a discrete function of the average wind speed. This relation is the so-called "power curve". It is plotted in the upper diagram of figure 19 in a discrete manner.

In order to calculate the energy capture from the power curve, the relation between the average wind speed and the time in one year during which this wind speed occurs is needed. While this data can be measured for each individual site, there are also some ideal distributions, which approximate the real conditions. These distributions will be described here according to [15, 37].

The most general one is the Weibull distribution, which is given by the following formula:

$$h_{Weib}(\bar{v}_w) = \frac{k}{a} \left(\frac{\bar{v}_w}{a} \right)^{(k-1)} e^{-\left(\frac{\bar{v}_w}{a} \right)^k} \quad (36)$$

Here, k is the shape parameter and a is the scale parameter. The relation between the annual mean wind speed $\bar{v}_{w,a}$ and the scale parameter a is:

$$\bar{v}_{w,a} \approx a \sqrt[k]{0.287k^{-1} + 0.688k^{-0.1}} \quad (37)$$

The resulting frequency distribution of the Weibull distribution is plotted in figure 18 for several scale factors and two annual mean wind speeds. According to [37], the shape parameter k is usually between 1 and 3. Right in the middle of the two is the shape parameter of $k = 2$, for which the Weibull distribution becomes a Rayleigh distribution with the following equation:

$$h_{Rayl}(\bar{v}_w) = \frac{\pi}{2} \frac{\bar{v}_w}{\bar{v}_{w,a}^2} e^{-\frac{\pi}{4} \left(\frac{\bar{v}_w}{\bar{v}_{w,a}} \right)^2} \quad (38)$$

This distribution is also used very often for the frequency distribution of the wind speed. In this study, it is always used if nothing else is specifically mentioned.

The discrete probability with which the wind speed lies within a given interval of $\left[\bar{v}_w - \frac{1}{2} \Delta v_w, \bar{v}_w + \frac{1}{2} \Delta v_w \right]$ can be calculated from

$$p(\bar{v}_w) = \int_{\bar{v}_w - \frac{1}{2} \Delta v_w}^{\bar{v}_w + \frac{1}{2} \Delta v_w} h(v_w) dv_w. \quad (39)$$

If the interesting interval of the wind speed is sufficiently narrow, the probability can be approximated as

$$p(\bar{v}_w) \approx \Delta v_w h(\bar{v}_w). \quad (40)$$

This approximation is used throughout this work.

The time in one year during which the average wind speed lies within the wind speed band is then found from the equation

$$t(\bar{v}_w) = p(\bar{v}_w) t_{year}, \quad (41)$$

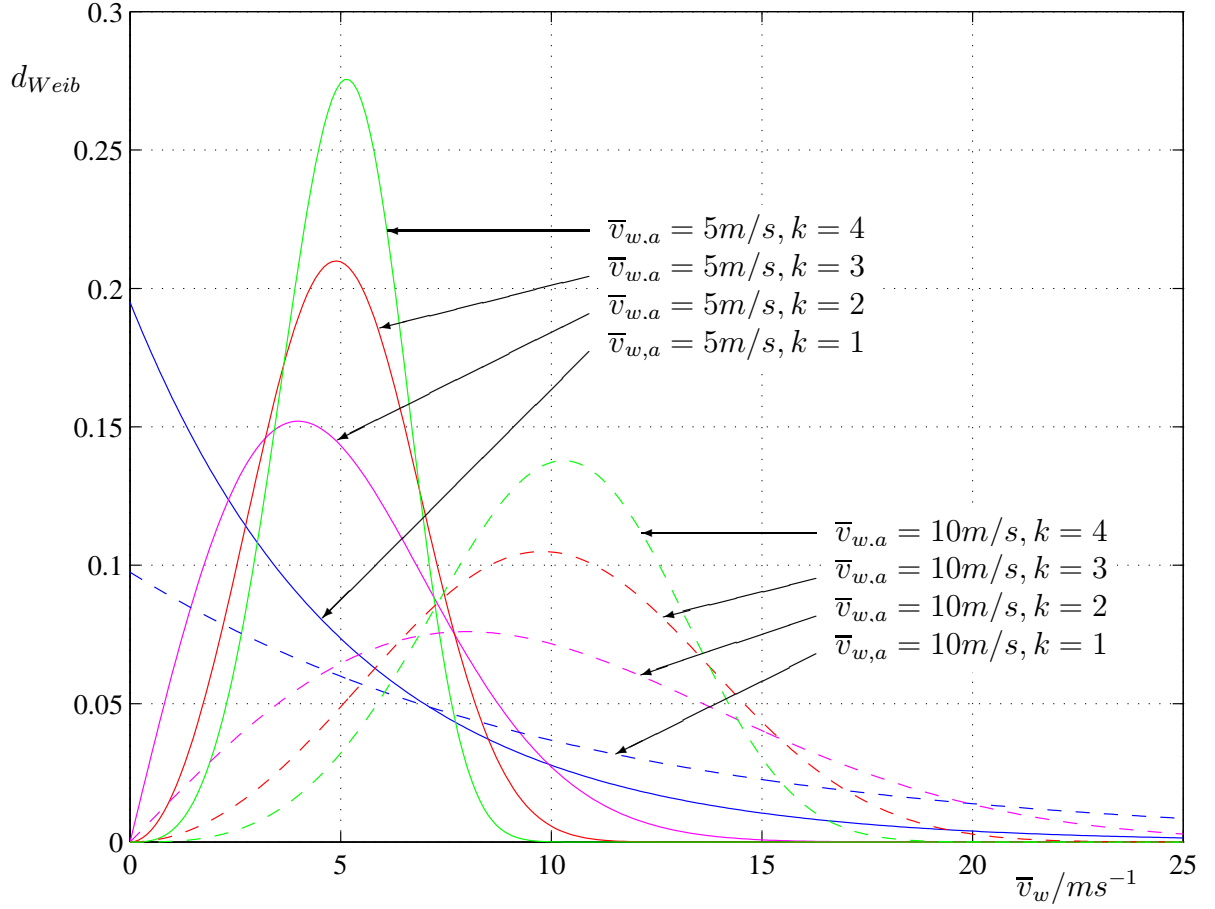

Figure 18: Weibull distributions for different scale Parameters and shape parameters

where t_{year} denotes the duration of one year (i.e. $8760h$). These equations are evaluated for all m different wind speeds, which leads to a discrete probability distribution. Such a distribution is shown in the middle diagram of figure 19 for a Rayleigh distribution and an annual mean wind speed of $\bar{v}_{w,a} = 7m/s$. It has to be noted that the bars for the wind speeds of $0.5m/s$ and $1.5m/s$ are not shown, because as mentioned above no simulations were done for these low wind speeds, so that they do not deliver any contribution to the annual energy capture regardless of the concept under consideration. If these two bars were also present, then the sum of all bars would be equal to the duration of one year, i.e. $t_{year} = 8760h$.

For each wind speed the energy captured can be calculated from

$$E_v(\bar{v}_w) = \bar{P}_g(\bar{v}_w) t(\bar{v}_w). \quad (42)$$

The results of these calculations are displayed in the lower diagram of figure 19. It can be noted that the energy capture is very low at low wind speeds as well as at high wind speeds, but for different reasons. At low wind speeds the wind turbine cannot deliver enough power, while high wind speeds occur only for short times during a year.

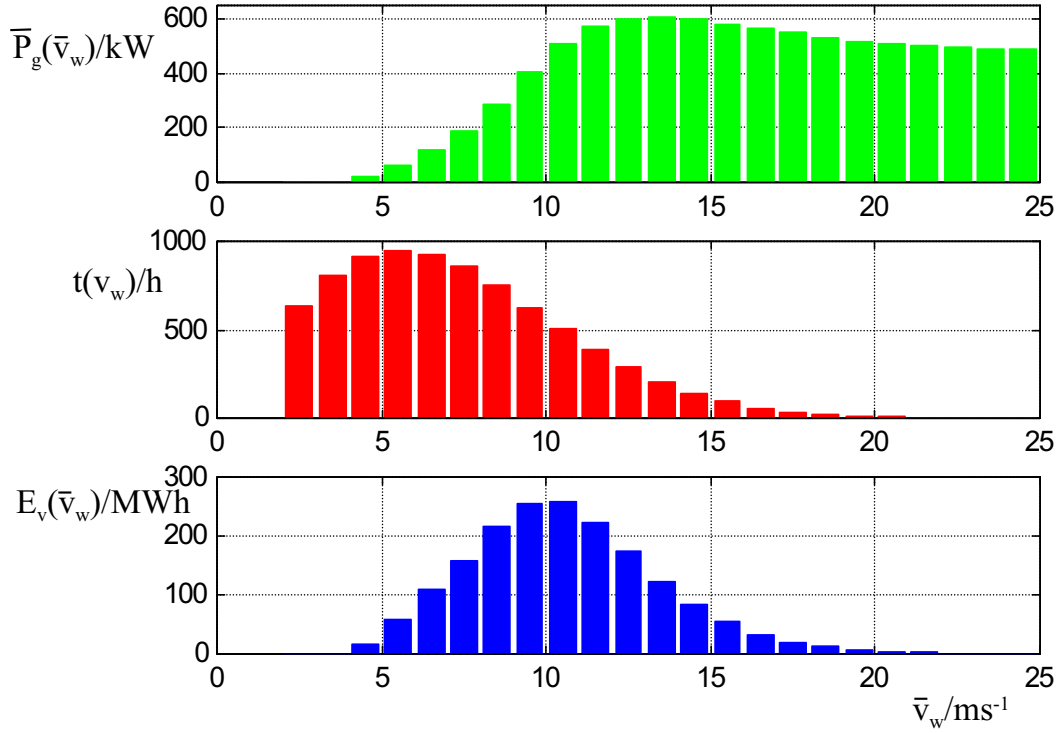

Figure 19: Calculation of the energy capture (example: stall controlled two speed concept).

The energy capture in the year is now found by summing up all the bars in the lower diagram of figure 19, which can be expressed mathematically as

$$E = \sum_{j=1}^m E_v(\bar{v}_{w,j}), \quad (43)$$

where m denotes the number of wind speeds used (here 23).

Finally, one interesting point should be mentioned here as it will be needed for some explanations later: This process of calculating the annual energy capture can also be interpreted as a weighting of the power curve with the probabilities of the individual wind speeds, followed by a multiplication with the duration of one year. If seen in this way, it is clear that varying the average wind speed will shift the portion with the high weights to different portions of the power curve. It follows that for sites with different wind conditions the behaviour of the wind turbine at different wind speeds will be most important. Also, when the shape parameter of the Weibull distribution is changed, it can be concluded from figure 18 that the weight will be concentrated on one portion of the power curve (with increasing shape parameter) or flattened out on larger portions of the power curve (with decreasing shape parameter).

5 Simulation results in the time domain

Although the main aim of this study is to analyze the energy captured by the individual concepts and to show the dependence of the differences from several parameters, it is also necessary to show some time characteristics. There are three reasons for this necessity:

- The first one is to show that the controllers and the simulation models of the different concepts work properly.
- The second one is to show several properties which are inherent in the different control concepts and which show up first in the time characteristics, but which have also an impact on the energy capture. Later, these properties can help a lot to explain the dependence of the energy capture on several parameters.
- Finally, the third one is to get an impression of the power quality of the different concepts, although the controllers are not optimized in this respect. The simulation model provides only the time characteristic of the active power, but as reference [40] shows, even here some differences between the control strategies can be expected.

There are three main areas where the time characteristics are interesting:

- The first one is at low average wind speeds, where the wind speed never reaches its rated value, so that power limiting doesn't occur. In this area, the main goal is the maximization of output power, with power quality being a second topic.
- The next one is around rated wind speed, where time intervals of power limiting and time intervals of partial load operation alternate. In this area, a smooth transition between the power maximization and the power limiting is of big importance.
- The third area is at very high wind speeds, where the wind turbine is always in power limiting mode. As there is more than enough power in the wind here, the main goal is a smooth time characteristic of the output power.

In the following, for each of the three areas there will be two figures, one for low turbulence (10%) and one for high turbulence (20%). The common parameters of all these figures are a design tip speed ratio of $\lambda_D = 6$ and the usage of the aerodynamic profile Goettingen Goe 758. All results will be shown in a time interval of 100s.

5.1 Operation at partial load

For the partial load time characteristics, an average wind speed of $5.5m/s$ was selected. This is the lowest wind speed value in the simulation for which all concepts have a positive average output power. Figure 20 shows the results for low turbulence.

It can be seen that there are several time intervals during which the stall controlled single speed concept doesn't deliver energy to the grid but consumes energy instead.

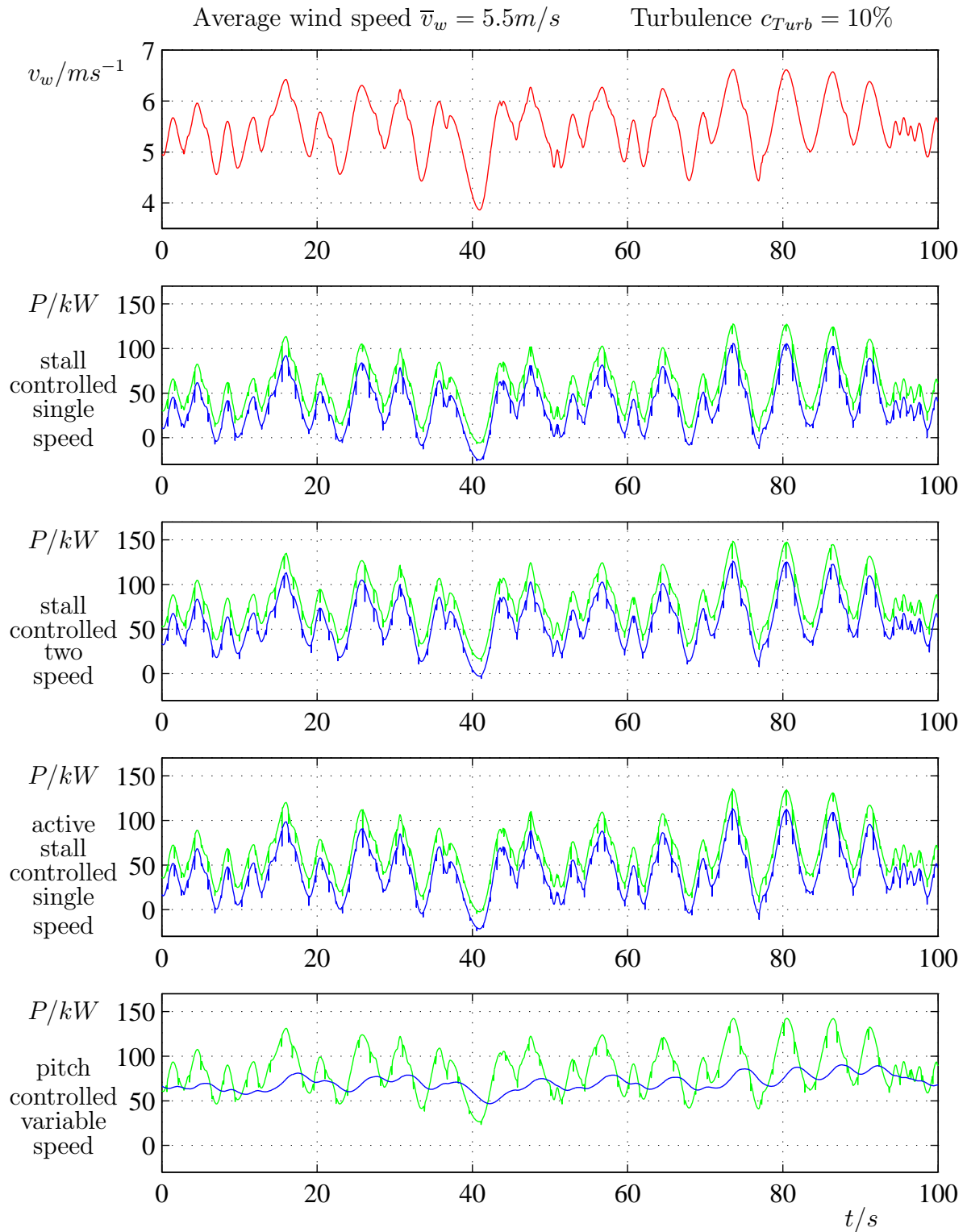

Figure 20: Behaviour of four different control concepts. In the power diagrams, upper line is rotor power and lower line is power fed to the grid.

Most of the time this is due to the losses, but shortly after 40s the rotor power drops below zero too. Actually, this means that either the aerodynamic losses consume the power or that the wind turbine *accelerates* the wind. To put it more drastically, it acts as a huge ventilator during this time interval. This is an inherent drawback of the constant speed concept, as the rotor speed cannot be adapted to the wind speed.

Other interesting points are the frequent sudden drops in rotor power as well as in grid power. These periodic drops are the moments when a rotor blade passes in front of the tower.

If the time characteristic of the stall controlled two speed concept is compared to the above, it can be seen that it always captures more power, because its slower rotor speed is better adapted to the low wind speed. It also avoids “ventilator operation”.

In contrast to this large and easily visible gain, the time characteristic of the active stall controlled single speed concept doesn’t show a very large gain. However, there is a small gain which can be seen most clearly at the very low wind speed shortly after 40s, as the rotor power of this concept doesn’t drop below zero as long as the stall controlled concept does. This small gain is achieved by pitching the rotor blades to the optimum pitch angle corresponding to the actual wind speed.

Finally, there is the pitch controlled variable speed concept. The variable rotor speed is very effective in reducing the deep sags in the rotor power at low wind speeds (for example shortly after 40s). However, the maximum rotor power achieved in the strong wind gusts around 80s is also somewhat lower than the values achieved by the two speed system. The reason for this is that the rotor speed cannot follow the rapid changes in wind speed, so that it is below its optimum value during these gusts. The result is that the tip speed ratio also falls below its optimum value and the power coefficient decreases. However, in the average there is still a remaining gain. But the most impressive feature of this concept is the rather smooth output power, which is achieved because the energy from the wind gusts is stored in the rotor inertia during a speed increase and used to fill up power sags during negative wind gusts. This ensures a higher power quality⁴³.

Only these four concepts are shown here, because the behaviour of the other concepts can be easily concluded from these: The active stall controlled two speed concept behaves very similar to a combination of the stall controlled two speed and the active stall controlled single speed concepts. However, its gain from pitching the blades to their optimum angle when compared to the stall controlled two speed concept is even smaller than the difference between their single speed counterparts. The reason is that the rotors of the two speed concepts operate closer to their optimum tip speed ratio, so that pitching the blades cannot result in a similar increase of the power coefficient. The pitch controlled concepts have exactly the same behaviour as the active stall controlled ones, because they are able to pitch their blades in exactly the same way. The stall controlled, variable speed concept has exactly the same behaviour as its pitch controlled counterpart, as their only difference is in the way of power limiting, which is not necessary in these low wind speeds.

⁴³The power quality is in reality also influenced by several other factors, like the harmonics of the power converter in variable speed systems and the reactive power consumption of the asynchronous generators used in single speed and two speed systems. As all these things are not topics of this study, the term power quality means only a rather smooth time characteristic of the output power here.

As figure 21 shows, an increased turbulence leads of course also to increased power fluctuations. The behaviour of the stall controlled single speed concept is roughly what can be expected. At high wind speeds, the power sags when a rotor blade crosses in front of the tower can be seen even more clearly. Also, now there are several times where “ventilator operation” occurs.

The stall controlled two speed concept is most of the time still able to deliver more power than its single speed counterpart. However, as the minimum wind velocities are lower here, it cannot avoid to draw power from the grid entirely, which is used to compensate its losses, although “ventilator operation” is still avoided. But it is also interesting to note that during the strong wind gust around 35s, the rotor power of the two speed concept is lower than the rotor power of the single speed concept. Consequentially, the grid power of the two speed concept is also lower than the grid power of the single speed concept. The reason for this is that during this gust the wind speed increases to a value larger than the optimum wind speed for low speed operation. This means that the tip speed ratio drops below its rated value and the rotor is near to being stalled so that its power becomes smaller than the power of full speed operation. While this protects the low speed winding of the generator (or the small generator) from overload, it also reduces the energy capture. As low speed operation is also used for an average wind speed of $6.5m/s$ (because the average energy output at 10% turbulence is still larger than for high speed operation), this phenomenon will occur even stronger there. The result can be seen in the power curves given in section 6.1.

The active stall controlled single speed concept has again a lower power gain above the passive stall controlled concept and it is not able to avoid “ventilator operation”.

The pitch controlled variable speed concept again shows the benefits of its possibility to store energy in the rotor inertia. It provides a much smoother output power not only by flattening the grid power, but also by eliminating the power sags caused by rotor blades passing in front of the tower. Because of its variable rotor speed, this concept reaches the same high peak in rotor power during the wind gust around 35s as the stall controlled single speed concept and still avoids acting as a ventilator. However, in the very last wind gust at around 90s, something seems to go wrong. The rotor power doesn’t follow the wind speed as all other concepts do, and it also doesn’t reach the maximum rotor power reached by the stall controlled two speed concept.

The reason can be found by looking at the time characteristic just before this wind gust. Here, the grid power has fallen to very low values, which also indicates a very low rotor speed (because the grid power is proportional to the third power of the rotor speed). During the following wind gust, the rotor inertia prevents the rotor from accelerating fast enough. As the rotor remains too slow, the tip speed ratio drops and the rotor is stalled, which limits the power taken from the wind and therefore also the acceleration of the rotor.

Another proof for this explanation is the absence of the typical sags in the rotor power during this acceleration phase. The absence of this sags means that the rotor power doesn’t drop if the wind speed is reduced when a rotor blade passes in front of the tower. This means that the rotor power doesn’t depend much on the wind speed, or, to say it in other words, that the rotor is operated in an area of the power curve where its slope is very flat, as it is when stall occurs.

Of course, stalling the rotor at low wind speeds is totally unwanted and results in

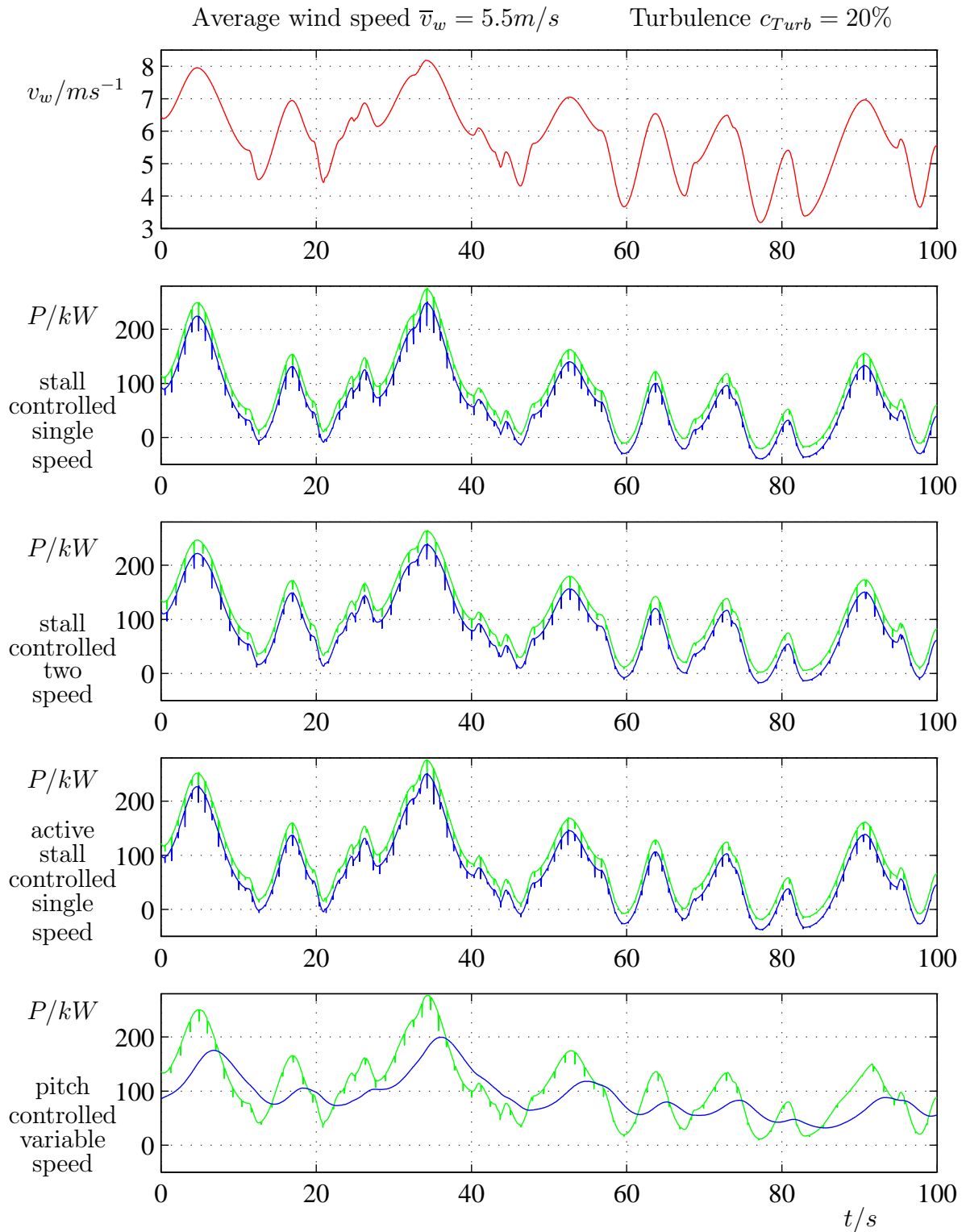

Figure 21: Behaviour of four different control concepts. In the power diagrams, upper line is rotor power and lower line is power fed to the grid.

a loss of energy.

It can also be shown that for a constant turbulence, the danger of such an unwanted stalling of the rotor decreases with increasing rotor (and therefore wind) speed. The reason for this is as follows: Let's assume that the rotor speed is increased by factor f . As stall occurs at a constant tip speed ratio regardless of rotor speed, the stall effect will occur at a wind speed which is larger by the same factor f . The rotor power is proportional to the third power of the wind speed, so the power at this point where stall occurs is larger by f^3 . Because power is the product of torque and speed, the torque at stall has increased by a factor of f^2 . As the inertia is constant, this means that the acceleration of the rotor is also larger by factor of f^2 . On the other hand, as the power controller tries to keep the tip speed ratio constant, it is logical that the average wind speed has also increased by a factor of f . As the turbulence is normalized to the wind speed, the absolute amplitude of the wind gusts will also increase by the factor f , and consequentially, the absolute amplitude of the rotor speed oscillations will also increase by the factor f . However, the rotor speed changes faster by f^2 , which means that the time until the amplitude can be reached decreases by $\frac{1}{f}$. This means that the risk of stalling the rotor will decrease with increasing wind speed if the rise time of the wind gusts remains constant⁴⁴. So, luckily, the risk is biggest at very low wind speeds where the loss of energy is small due to the small amount of power available in the wind.

Another consequence of this relation should also be noted: From a control system point of view, one can interpret the above mentioned proportional relations in a way that the rise time of the speed control loop is inverse proportional to the wind speed. This means that the smoothing of the grid power by usage of the rotor inertia works best at low wind speeds, while its influence decreases at higher wind speeds.

5.2 Operation near rated wind speed

At this wind speed, the two speed concepts operate in their high speed mode. Therefore, they behave like the respective single speed concepts and will not be shown separately. Figure 22 shows the behaviour of the single speed and variable speed concepts at low turbulence.

It can be seen that all single speed concepts have deep power sags when there are negative wind gusts. The possibility to adjust their pitch angles is of no visible use (at least at this power scale) for the active stall and pitch controlled concepts.

But the main interest lies on the transitions from partial load to rated power and vice versa. These transitions are rather smooth for the passive stall controlled concept, as the stall doesn't occur at the same moment on the whole rotor blade. In reality, the dynamic stall effects which delay the stall will probably sharpen this corner at the entrance into stall a bit.

⁴⁴As the rise time of the wind power gradient follows the complicated equation 25, it is not so clear whether the time interval of the wind gusts is constant. However, counting the gusts in figures 21, 23 and 27 gives 12, 12, and 11 wind gusts, which justifies this assumption at least for the used model. The same effect can also be seen in the time characteristics for 10% turbulence, where the same pattern of wind gusts can be seen in the figures 20 and 22, and with a slight time delay also in figure 26. As these figures are details of longer time characteristics generated from the same random number sequence, this pattern repetition is also an indication that the average rise time of the wind gusts is not too much varying with average wind speed.

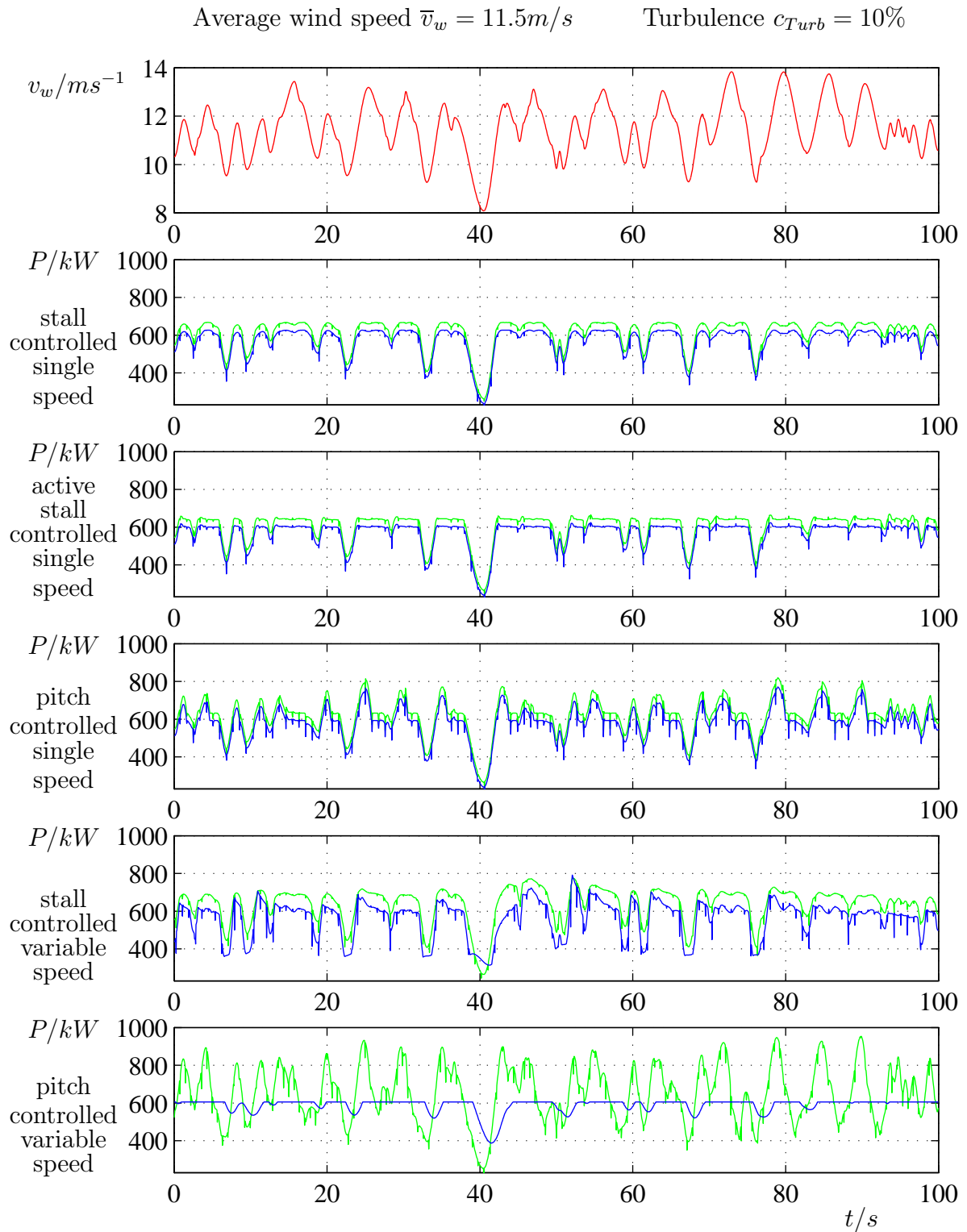

Figure 22: Behaviour of five different control concepts. In the power diagrams, upper line is rotor power and lower line is power fed to the grid.

The active stall controlled single speed system is able to enforce the stall almost instantaneously when it is needed. Therefore, its transitions are sharper, which provides a little gain of energy.

The pitch controlled single speed concept seems to have some problems when entering power limitation. As will be discussed below, its pitch drives are rather slow when compared with the needed pitch angles, so that it takes some time to pitch the blades to the right angle. Therefore, there is always an overshoot in power when power limitation is entered. Also, this concept shows excessive power sags when a rotor blade passes in front of the tower during power limiting, which the stall controlled concepts don't show when they are limiting power. The reason is that the power curve is very steep when the blades are pitched towards feather direction, so that a given change in wind speed results in a large change in power (see also footnote 28). For the stall controlled concepts, things are vice versa. Their flat power characteristic makes them very insensitive to such sudden wind speed changes.

The stall controlled variable speed concept shows very steep power changes when entering and leaving power limitation. The reason is that the stall in this concept is enforced by braking down the rotor (or at least by stopping its acceleration), which calls for faster changes in grid power than in rotor power to work.

The pitch controlled variable speed concept shows the same high overshoots in rotor power when entering power limitation which were already seen for the pitch controlled single speed concept. In fact, the overshoots here are even higher. However, the excessive power taken from the wind can be easily stored in the rotor inertia, so that the grid power is kept constant.

When it comes to power quality, it can be concluded that the pitch controlled single speed and probably also the stall controlled variable speed concept have a poorer power quality than the stall controlled single speed concepts, while it doesn't make much difference whether the stall control is by active or passive means. The pitch controlled variable speed concept seems to provide the best power quality.

The time characteristics for high turbulence in figure 23 show all of the above mentioned effects more drastically.

Especially the power sags during negative wind gusts are much deeper. They reach now down to zero grid power for the single speed concepts, while the variable speed concepts are even during this deepest sag (at around 95s) still able to deliver roughly 150kW.

Something which is more obvious in this figure than in figure 22 (although it is visible there, too) is the slow decrease in power of the passive stall controlled single speed concept when the wind speed becomes really large, as for example between 45s and 50s. The reason is that the single speed concept depends totally on the natural rotor characteristic. If the rotor is an optimum design according to Betz-Schmitz (see [15] for details), this natural rotor characteristic decreases the power coefficient for increasing tip speed ratio, as stall is entered. However, this decrease in power coefficient is not necessarily such that the resulting output power is constant. For the rotor used here, the resulting output power decreases with increasing wind speed in the stall area until a certain wind speed is reached, where it starts to increase again. This leads to the slight decrease in power.

The individual behaviours of the concepts will now be explained in more detail with

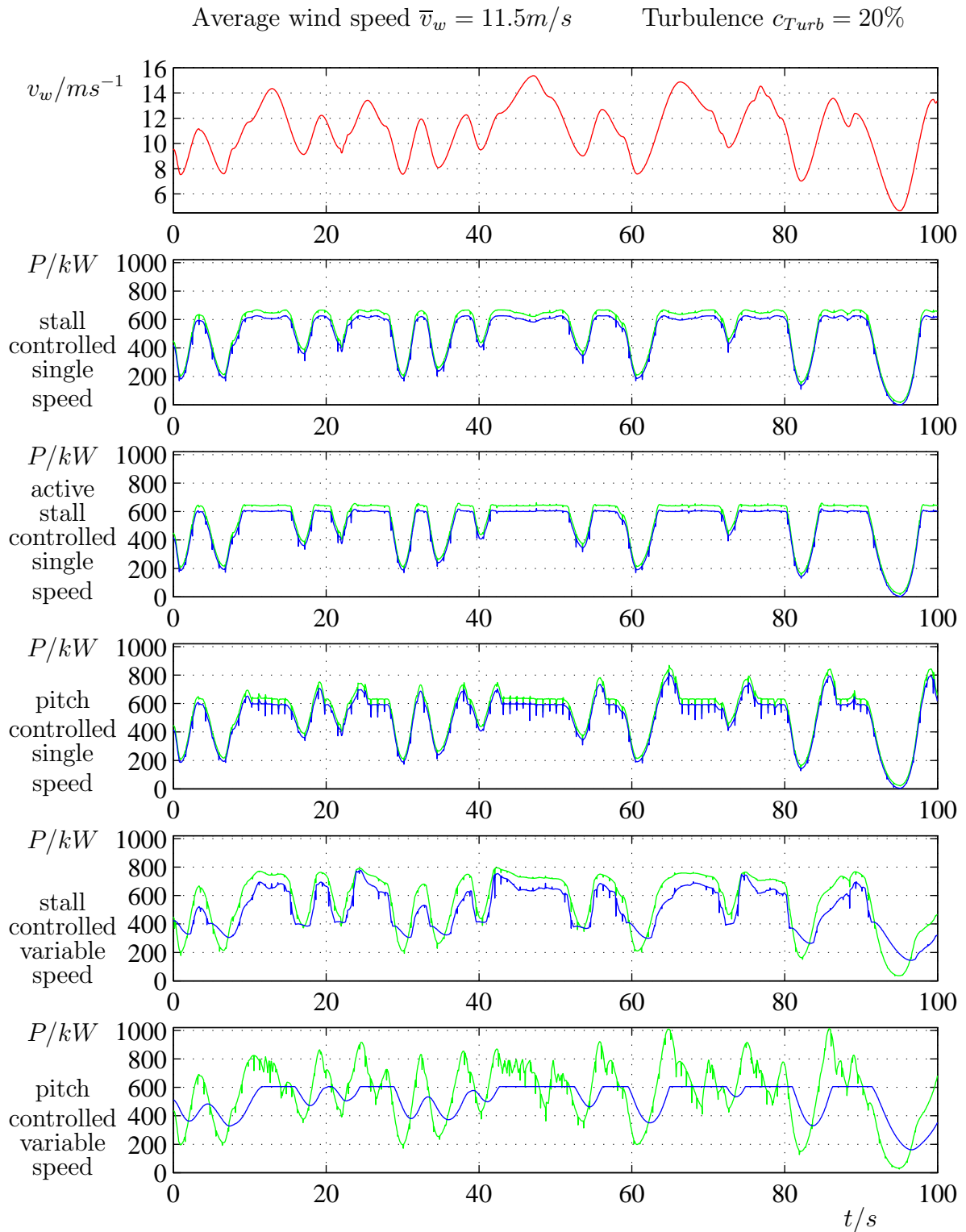

Figure 23: Behaviour of five different control concepts. In the power diagrams, upper line is rotor power and lower line is power fed to the grid.

the help of figure 24 for the single speed concepts with pitchable rotor blades and figure 25 for the variable speed concepts.

In order to show the completely different behaviour of the active stall controlled and pitch controlled single speed concepts, figure 24 depicts not only the output power of these concepts, but also the pitch angles. To give an insight in the differences, the large wind gust after 60s, where the wind speed raises from below 8m/s to more than 14m/s and drops than back to 10m/s will be described in detail.

First, the active stall controlled concept will be looked at. When the wind speed starts to increase at 61s, the pitch angle is around 1.3°. When looking at figure 17, it can be seen that this is the right angle for this rotor power (a little above 200kW). As the rotor power increases, the needed pitch angle decreases until 500kW are reached. As can be seen in figure 17, from now on the pitch angle has to increase very fast to be optimum. This increase is the left side of the pitch angle “spike” in figure 24. When the power level reaches rated power (and the pitch angle reaches 0.3°⁴⁵), the power controller induces stall by rapidly decreasing the pitch angle. But the wind speed increases further and after the stall is developed, the power would fall below its rated value if the pitch angle would be kept constant, because the angle of attack would continue to grow. In order to avoid this, the pitch controller increases the pitch angle so that rated power is delivered all the time during the wind gust. When the wind speed decreases, the procedure is repeated in reverse order.

Next, the behaviour of the pitch controlled concept during the same wind gust will be analyzed. As long as the actual wind speed is below rated wind speed (from 61s to roughly 63s), the power is maximized by using the optimum pitch angle exactly as in the active stall controlled concept. The curve only seems to be different due to the different scale of the α -axis. But as soon as the power increases above rated power, this similarity ends. The power controller now increases the pitch angle as fast as possible to limit the output power to its rated value (except for the short periods where a rotor blade is in front of the tower and the controller is therefore blocked, which show as steps). However, although the rotor blades are turned three times as fast as in the active stall controlled concept, this is still much too slow to keep the output power at its rated value. Therefore, the output power increases up to almost 800kW, while the pitch controller turns the blades as fast as possible towards larger angles.

When the output power is finally brought back to its rated value, the pitch angle has reached 15° and the wind speed already starts to fall again. From now on, the pitch drives are fast enough to follow the wind speed variation and the output power is kept at its rated value, until the wind speed starts to drop quickly. Now there is a short time interval (from 71s to 73s) during which the pitch controlled concept is unable to deliver its rated power although there is enough wind and the active stall controlled concept is still able to deliver rated power. The reason is again that the rotor blades cannot be turned fast enough, although this time they have to be turned in the other direction.

From this, it can be concluded that the dynamic response of the pitch controlled system is much worse than the dynamic response of the active stall controlled system. The reason is of course that the pitch angles required by the pitch controlled system

⁴⁵This is a little lower than in figure 17. The reason is the tracking error of the pitch angle controller during this steep increase.

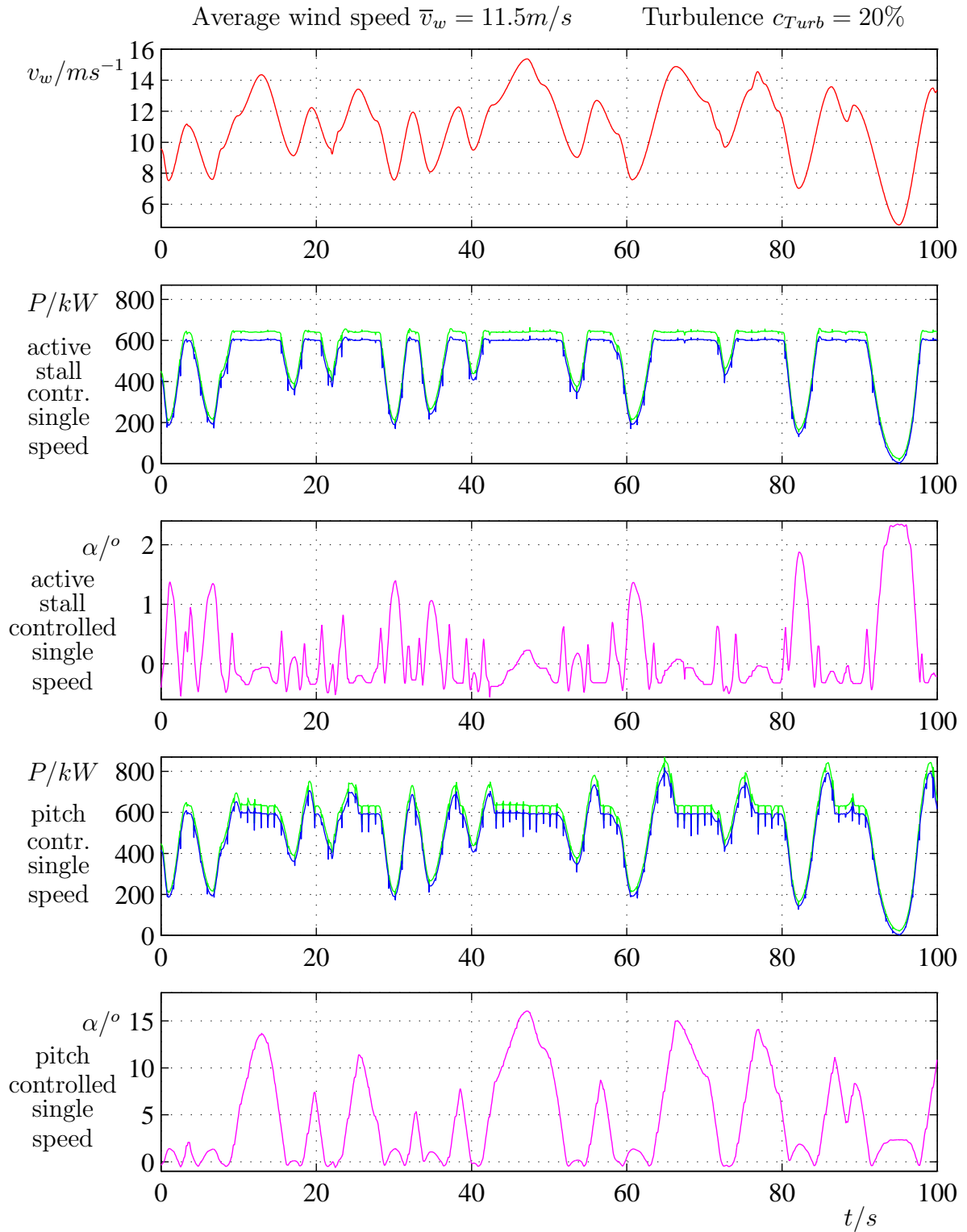

Figure 24: Details of the behaviour of two different control concepts with fixed rotor speed. In the power diagrams, upper line is rotor power and lower line is power fed to the grid.

(around 15°) are much larger than the ones required by the active stall controlled system (around 0.6°). As the difference in needed pitch angle is by a factor of 25, it cannot be compensated by the increase in pitching speed by a factor of 3.

It can also be noted that the power-time-area (which is the energy) gained due to the overpower at the beginning of the wind gust is much larger than the power-time-area lost at its end.

Naturally, the question arises why the pitch drives for the pitch controlled system were not assumed to be much faster. There are two reasons for this: The first one is that it becomes increasingly difficult to build such fast pitch drives with increasing turbine size, as when the rotor blades become larger, their inertia and the bending momentum at the blade root increase much faster than proportional to size. The second one is that the differences between the control concepts are to be shown. Therefore, the parameters should be as similar as possible. Starting from the pitch speed of the active stall controlled concept ($2^\circ/s$), the $6^\circ/s$ was the lowest pitch speed for which the pitch controllers of this concept and also of the pitch controlled variable speed concept worked.

On the other hand, if the pitch drives were assumed to be so fast that they can follow the wind speed changes immediately, than the output power curve would be the same as for the active stall controlled concept. Therefore, for faster pitch drives the results will always lie in between the results of the pitch controlled and the active stall controlled concepts shown here. So these two concepts form the boundaries within which the others will lie.

Figure 25 shows the details of the two variable speed concepts. To make the comparison easier, the same large wind gust after 60s will be used for the explanations where possible.

First the stall controlled variable speed concept will be discussed. During the time of low wind speed shortly after 60s, not only the rotor power but also the rotor speed have dropped, as energy is drawn from the rotor in order to provide a smoother time characteristic of the output power. Accordingly, the output power has dropped, too. When the wind speed increases, all three mentioned quantities start to increase, too. At around 65s, the rotor power has increased to a level where power limiting is necessary. The only way to decrease the rotor power is to decrease the rotor speed. Therefore, the power controller increases the output power rapidly over its rated value ($600kW$) at 65s, which forces the rotor to slow down. While this keeps the turbine in safe operation, it requires the grid to accept more than rated power.

When the wind speed has returned to its rated value (at 71s), the output power is decreased very rapidly because power limiting is no more necessary. Instead, the rotor is now allowed to accelerate freely. As the wind speed does not drop to very low values in the following, the rotor speed increases up to $25min^{-1}$. This rotor speed proves to be too high during the next wind gust (at 74s). Therefore, it has to be decreased very rapidly, which calls for a high grid power. The peak of the grid power lies around $750kW$, which is 25% above rated power.

Next, the behaviour of the pitch controlled variable speed concept will be described. Similar to the stall controlled concept before 61s, the rotor speed of this concept decreases to provide the energy necessary for smoothing the time characteristic of the output power. When the wind speed increases after 61s, the input and output power

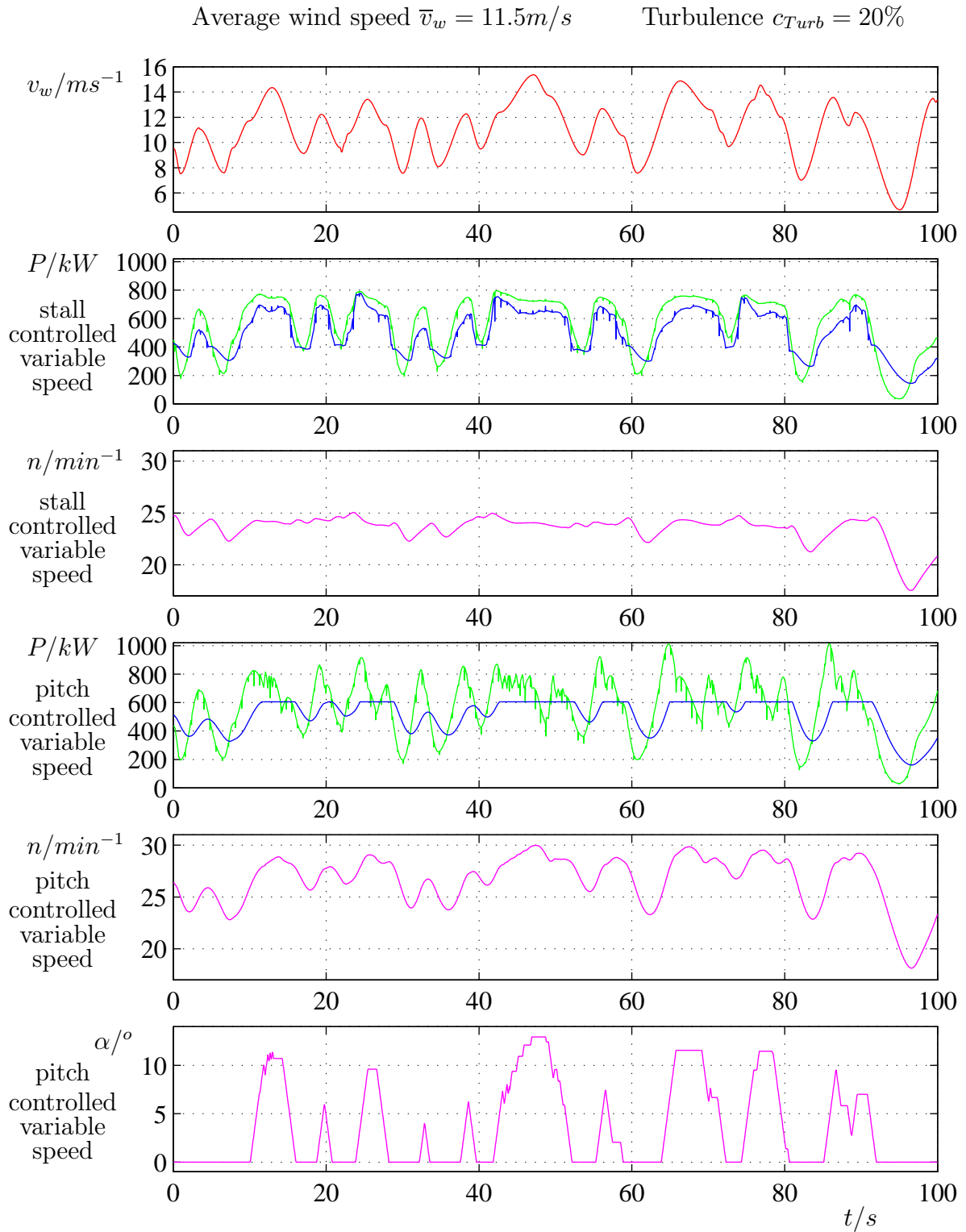

Figure 25: Details of the behaviour of two different control concepts with variable rotor speed. In the power diagrams, upper line is rotor power and lower line is power fed to the grid.

increase as well as the rotor speed. But then at 64s, the rotor power becomes larger than the 800kW mentioned in table 7. Therefore, the pitch controller starts pitching the rotor blades, even though the rotor speed is still low enough for the power controller to remain in partial load operation (i.e., the output power is still below its rated value).

Because the rotor blades are again not fast enough to follow the increase in wind speed immediately, the rotor power increases further (up to 1000kW). However, the power fed to the grid does *not* exceed its rated value of 600kW. The reason is that the power controller reduces the torque produced by the generator so that the output power is exactly its rated value. Because the rotor torque is higher than the generator torque, the rotor accelerates. As the pitch angle increases further, the rotor power decreases below 700kW and the pitch drives are stopped (the rotor speed is not yet high enough to cause the speed controller to pitch the blades further to decrease the speed).

When the wind speed decreases, the rotor power decreases, too. As the rotor power becomes smaller than the output power plus the losses, this means that the rotor speed also decreases. When the rotor speed becomes too small, the speed controller issues the command to turn the rotor blades back towards their normal position. While the increase in rotor power lets the rotor speed increase again, the rotor power reaches 800kW. At this limit, the pitch angle controller starts to turn the blades towards higher pitch angles again for a short interval. When the rotor power decreases below 700kW, the rotor blades are again turned towards lower angles for a short time interval as the rotor speed is still too low. The result is the pitch angle “spike” at 70s.⁴⁶ After some time, the rotor speed falls again, which causes the pitch angle controller to turn the blades back to 0°, as the wind speed decreases below rated wind speed.

It is also interesting to compare the time characteristic of the pitch angle of the variable speed concept with that of the pitch controlled constant speed concept. It can be seen that the variable speed concept starts the pitching later and uses a smaller maximum pitch angle when compared to the constant speed concept. There is also a difference when operating above rated wind speed: The variable speed concept doesn’t have to track the the wind speed with the pitch angle as accurately as the constant speed concept, because it has the rotor inertia as an energy storage.

5.3 Operation in power limiting

In this section, the behaviour of the different concepts at wind speeds much above rated wind speed will be shown. At these wind speeds, there is always much more power in the wind than the wind turbine can handle. Therefore, the wind turbine must be protected from this excessive power. As for the operation at rated wind speed, the two speed concepts operate at full speed here, so that they behave exactly like their single speed counterparts. Therefore, only the latter will be discussed here. Figure 26 shows the behaviour of the five remaining concepts for low turbulence.

The stall controlled concept is not able to deliver its rated power, since it depends entirely on the natural characteristic of the rotor, which gives decreasing power for

⁴⁶This spike should be avoided in the controller of a real wind turbine, as it might excite an eigenfrequency of the blades. However, it was tolerated here as it can be clearly seen that it has absolutely no influence on the energy gain.

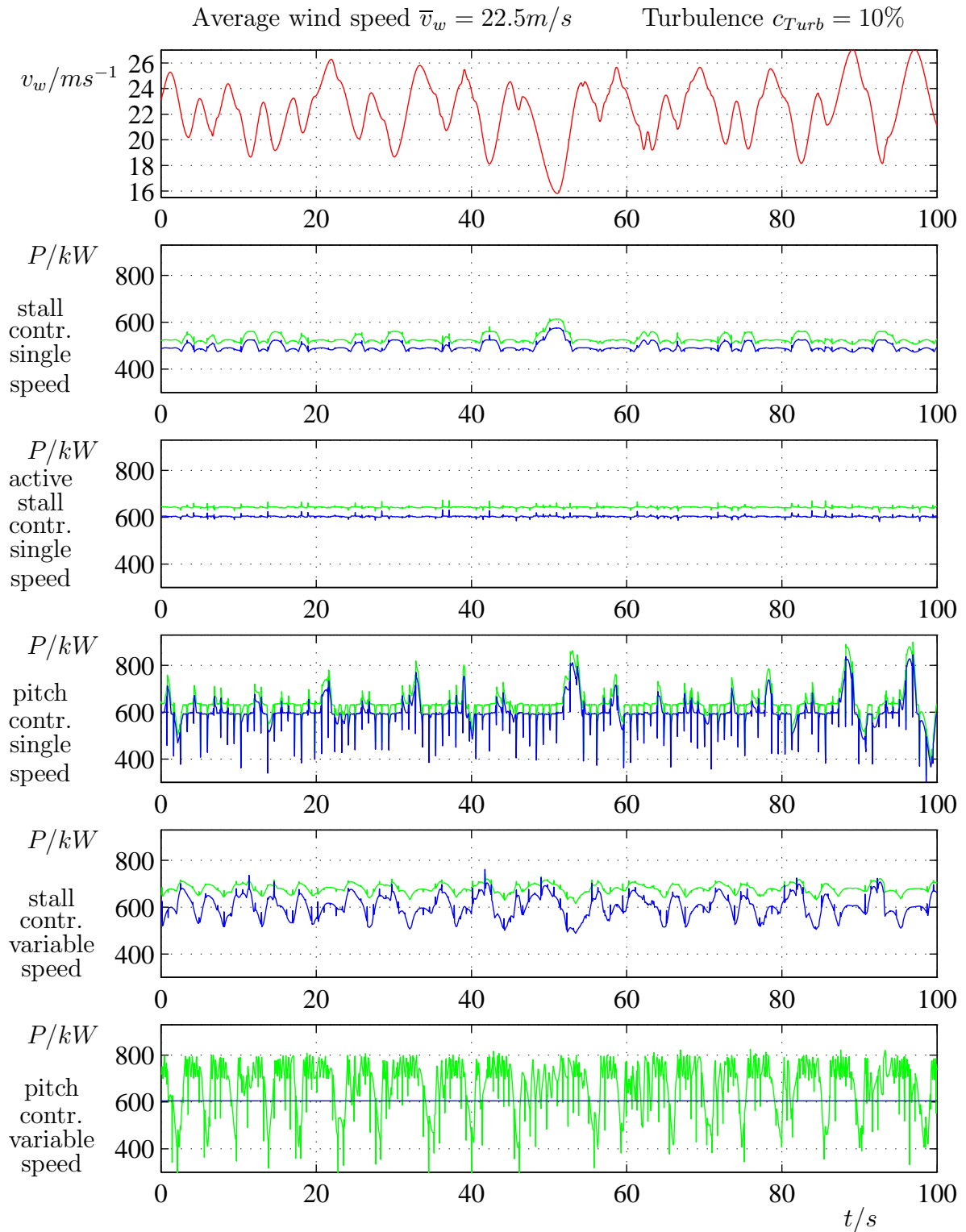

Figure 26: Behaviour of five different control concepts. In the power diagrams, upper line is rotor power and lower line is power fed to the grid.

wind speeds above rated wind speed. However, both the rotor power and the output power are rather smooth.

Even smoother are the two time characteristics for the active stall controlled concept. The possibility to turn the rotor blades is used here to adjust the output power to its rated value. Also, the influence of wind gusts can be compensated by small variations in pitch angle, which can be done almost immediately. As the power is also not that much dependent on wind speed when the rotor blades are stalled, the effect of tower shadow is also not large.

Exactly the opposite is true for the pitch controlled concept. While it is also possible to adjust the output power to the rated power, the required pitching speed is not always provided by the pitch drives, which sometimes leads as well to too high power as to too low power. Also, the influence of tower shadow on the rotor power as well as on output power is large, as the dependence of power on the wind speed is very strong for blades pitched into the direction of zero lift. Together, these two problems lead to a much lower power quality of this system⁴⁷.

The stall controlled variable speed concept shows a completely different behaviour. It has the inherent possibility to regulate the average output power to its rated value by means of a proper adjustment of the rotor speed, but it cannot achieve the same for the instantaneous power. The reason is the required control action. An example will make this clear: If the rotor power becomes too low, then the rotor speed must be increased in order to boost the rotor power up. But in order to increase the rotor speed, the rotor torque (and therefore the rotor power) must be larger than the generator torque (or the input power of the generator). As the rotor power is already too low, the only way to accelerate the rotor is to decrease the input power of the generator (and thereby also the output power) even further. As things are just vice versa when the rotor power becomes too large, it is clear that the output power will always oscillate irregularly around its rated value. This is what figure 26 shows.

Finally, there is the pitch controlled variable speed concept. Although the rotor power of this concept oscillates even more than in the pitch controlled constant speed concept, the output power is ideally smooth. This results from the power controller which adjusts the output power exactly to rated power and leaves the responsibility for the speed control entirely to the pitch controller.

Figure 27 shows the behaviour of the same concepts for a higher turbulence. Most of it is similar to the previous figure. However, the power spikes in the pitch controlled concepts have as well increased as the irregular oscillations of the stall controlled variable speed concept. It can also be noted that the power spikes of the pitch controlled constant speed concept are now considerably higher than for the pitch controlled variable speed concept.

Another interesting point is that the pitch controlled variable speed concept is unable to keep its output power up to rated power two times (at 45s and 98s), although the wind speed is still above rated wind speed. So the reason is not the insufficient

⁴⁷In real wind turbines, there are several factors which decrease these problems. One is the slip of the generator, which makes the rotor speed at least a little variable, and which is neglected in these simulations. There is also the possibility of attaching the gearbox to the nacelle with elastic means. This gives the gearbox and therefore also the rotor shaft some rotational elasticity, which will smooth the torque and thereby also the power to some degree [20].

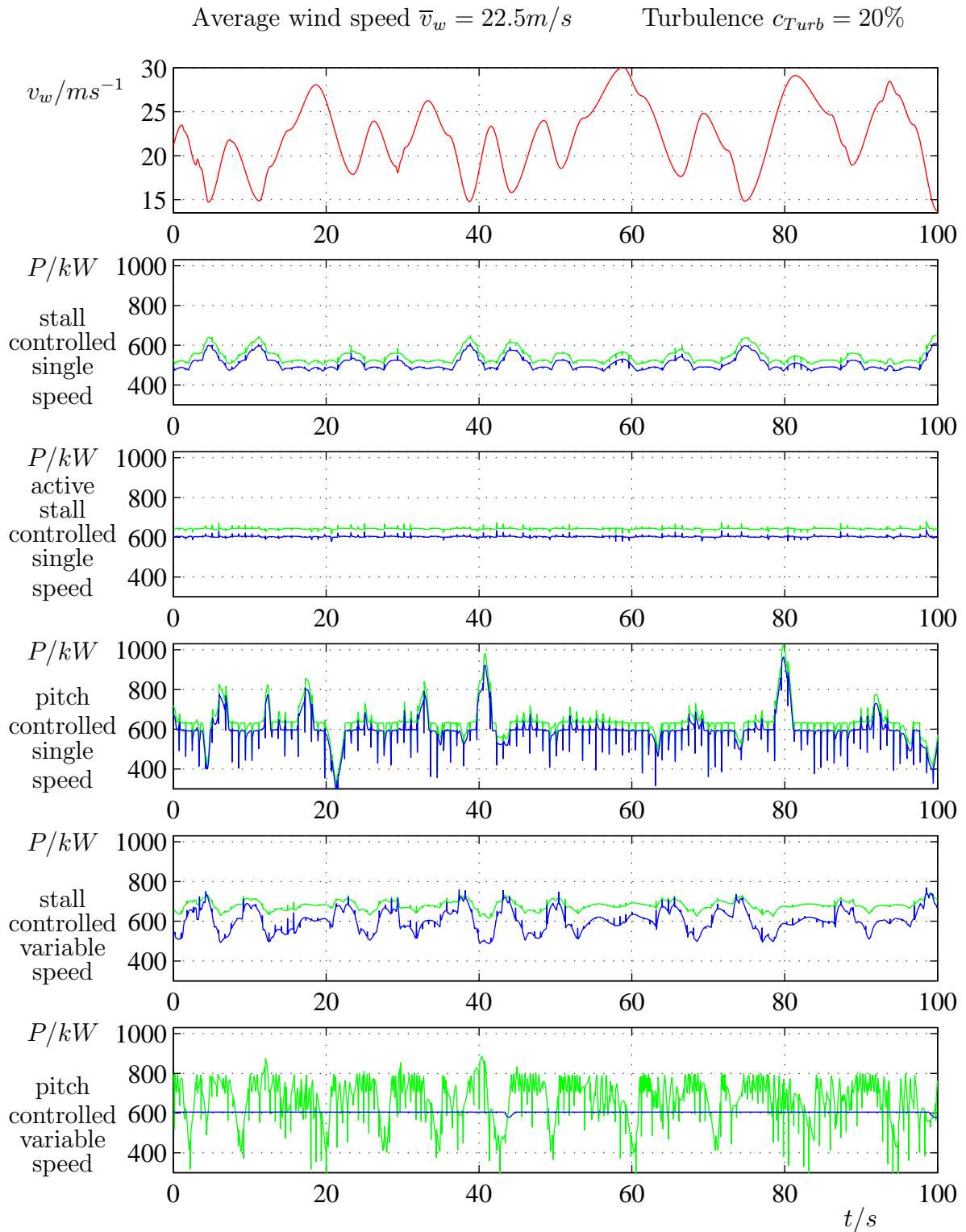

Figure 27: Behaviour of five different control concepts. In the power diagrams, upper line is rotor power and lower line is power fed to the grid.

power in the wind, but rather the insufficient speed of the pitch drives. One could argue that it would be possible to keep rated output power at these instances by slowing down the rotor a bit further and filling up the energy stored in its inertia just a bit later, but this would require a rather complicated controller capable of recognizing such situations. Additionally, if the wind speed would decrease further so that it would reach values below rated wind speed, the energy of the rotor inertia could not be filled up that easily. The result would then be a non-optimum rotor speed for the actual wind speed and therefore an even bigger loss of energy. As it is difficult (if not impossible) for the controller to guess whether the wind speed will or will not decrease below rated wind speed, no attempt in this direction was made⁴⁸.

The stall controlled constant speed concept and the active stall controlled constant speed concept are almost not affected by the increase in turbulence.

⁴⁸While it seems clearly impossible at first glance, it might be feasible to say if the possibility of such a decrease exists by taking into account the previously measured turbulence of the site and the current average wind speed in some sort of empirical knowledge. Therefore I made this restriction.

6 Simulation results in terms of energy capture

In this section, the influence of the different parameters on the relative energy capture of all the concepts will be explained.

First, some typical power curves will be shown to give an idea of the behaviour of each concept. Then, the energy capture of all the concepts will be shown and explained.

6.1 Power curves

For each concept, three power curves are shown, which have been gained at simulated turbulence levels of 0%, 10% and 20% respectively. These curves show the behaviour of the concepts for different average wind speeds and the influence of turbulence on the power curve. All curves are for the profile Goe 758 and a design tip speed ratio of 6. They have a resolution of $1m/s$ (as mentioned in section 4.10).

The power curve for 0% turbulence is identical to the steady-state power curve, as it would be calculated from the rotor characteristic when no wind gusts are taken into account. As reference [42] says that only turbulence levels below 15% will be taken into account when calculating the power curve, the power curve for 10% is probably close to the power curve which would be measured at type approval (except for the caveats in the model, of course). As mentioned before, this is also the turbulence level for which the calibration was done. Finally, the power curve for 20% will give an idea of the things which happen when the turbulence is higher.

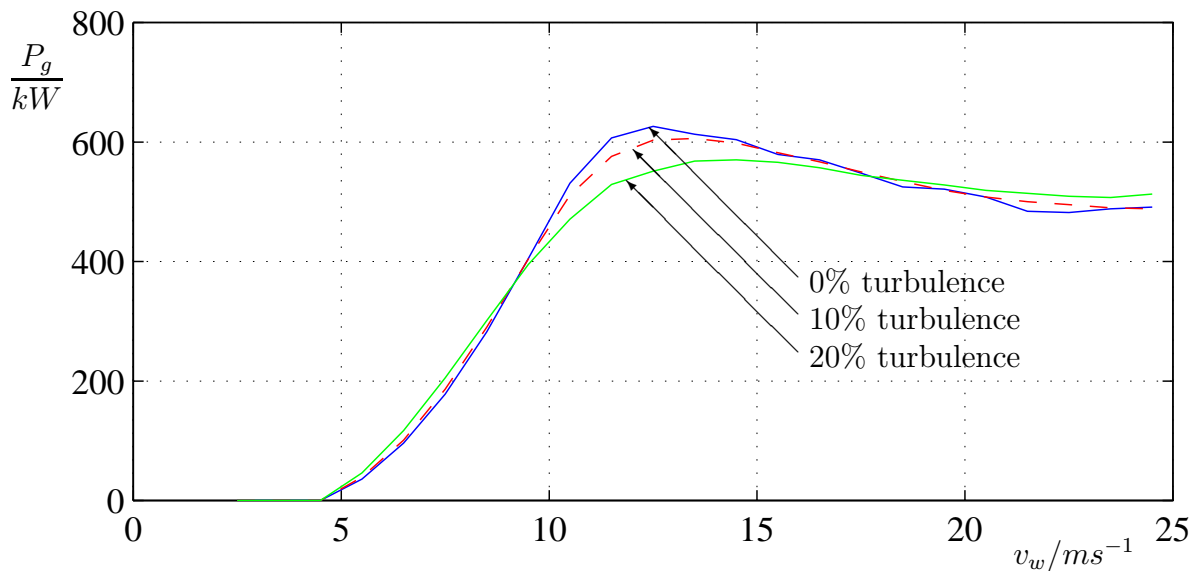

Figure 28: Power curves of the stall controlled single speed concept

Figure 28 shows the power curves of the stall controlled single speed concept. As this concept is not able to adapt to the wind speed at all, it is clear that its performance at low wind speeds is very poor. Production is not started much below $5m/s$. When continuing to higher wind speeds, the power curve for 0% turbulence shows a slope

of increasing gradient. Above 10m/s the gradient decreases again as stall begins to develop on some parts of the rotor. At 12.5m/s , the maximum power is reached. From now on, the power decreases because the stall reduces the power coefficient faster than the power in the wind increases. From 22.5m/s on, the power increases again.

It can be seen that an increase in turbulence results in an more rounded curve. This can be explained as follows: Because the aerodynamic model is without any time delay, the variations of the wind speed during wind gusts simply lead to an averaging of the power curve which was valid for 0% turbulence. Averaged are always the portions which are reached by the wind speed during wind gusts at the actual average wind speed. As is obvious, a higher turbulence means larger variations in wind speed and therefore averaging over a larger part of the power curve. The result of this averaging is that all curved parts of the power curve are moved towards the inner side of the curvature. This leads to an increase in power at low wind speeds, while it leads to a decrease in power around rated wind speed.

Figure 29 shows the power curves for the stall controlled two speed concept. It is clear that the only difference in comparison to figure 28 can be found at low wind speeds, where the turbine operates in low-speed mode. This happens below a wind speed of 7.5m/s , as can easily be seen by the sharp bend in the power curve for 0% turbulence. It can also be seen that the power production below this wind speed is larger for the two speed concept. Additionally, the cut-in wind speed is also lower, which again shows an improved performance at low wind speeds.

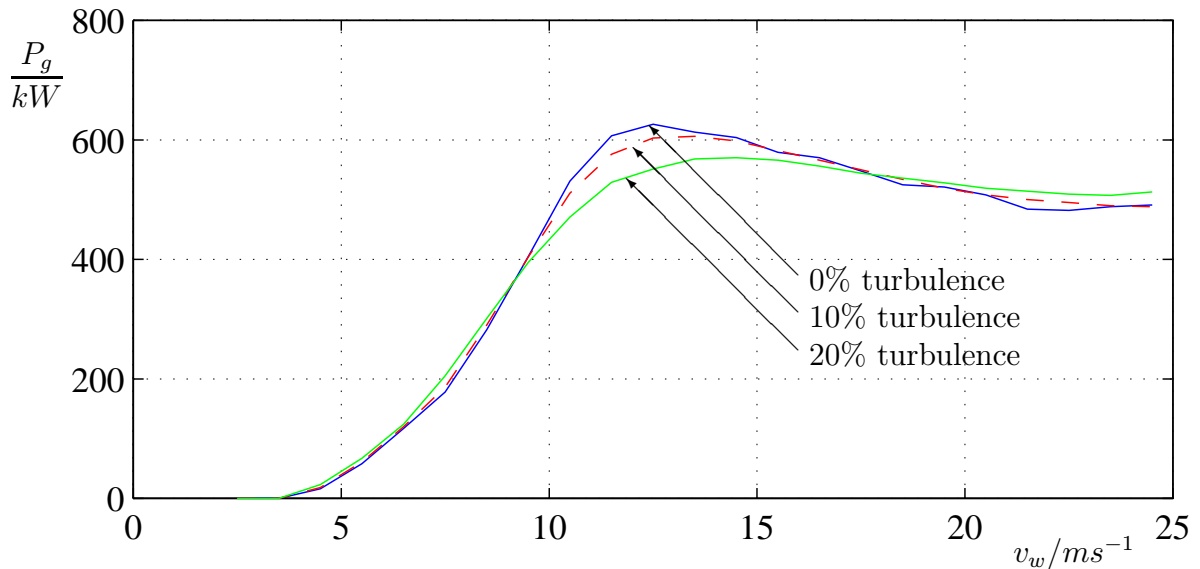

Figure 29: Power curves of the stall controlled two speed concept

The power curves for the active stall controlled single speed concept are shown in figure 30. The possibility to control the stall by turning the blades is useful at high wind speeds, where it is possible to cut the output power to exactly the rated power, as the curve for 0% turbulence shows. This exact limitation at high wind speeds almost

regardless of turbulence and wind speed is rather impressive⁴⁹.

In contrast, the possibility to adjust the angle of the rotor blades to its optimum value in partial load operation doesn't show a very big benefit at first glance. However, having a closer look it can be seen that the average power for 4.5m/s wind speed and 20% turbulence is somewhat above 0, which wasn't the case in figure 28 for the stall controlled single speed concept. Therefore, it can be concluded that a slight gain can be achieved by turning the blades to their optimum angle at low wind speeds

Like the time traces, the power curves show again that the dynamic behaviour of this concept is very good, as the power curves for higher turbulence are again simply an averaging of the power curve for 0% turbulence.

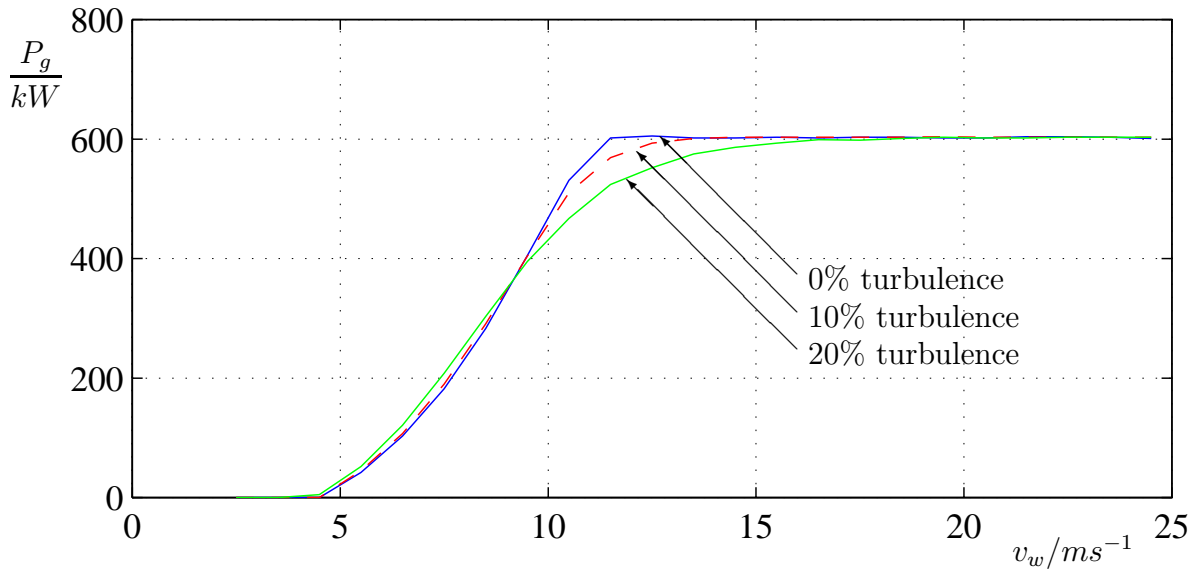

Figure 30: Power curves of the active stall controlled single speed concept

As expected, the two speed active stall controlled concept shown in figure 31 differs from its single speed counterpart only in the improved performance at low wind speeds. This is again the region below 7.5m/s , where the low speed operation mode is used.

The power curves for the pitch controlled single speed concept are shown in figure 32. In partial load operation, these curves are identical to those shown in figure 30. This is clear, as exactly the same optimization strategy is used for both concepts.

In contrast, the behaviour of the two concepts in power limiting is quite different. For the pitch controlled concept, it is no more simply an averaging of the power curve. Instead, the maximum power increases with increasing turbulence. As the maximum power at 10% turbulence was chosen to be the calibration point, the power limit for 0% turbulence had to be set to a lower value, which can be seen in figure 32. On the other hand, the power curve for 20% turbulence shows some overpower even in the average power. These problems in power limiting are the result of the rather poor dynamic behaviour of this concept, which is discussed in more detail in section 5.2.

⁴⁹The slight curvature around rated power is a result of the limited horizontal resolution of 1m/s .

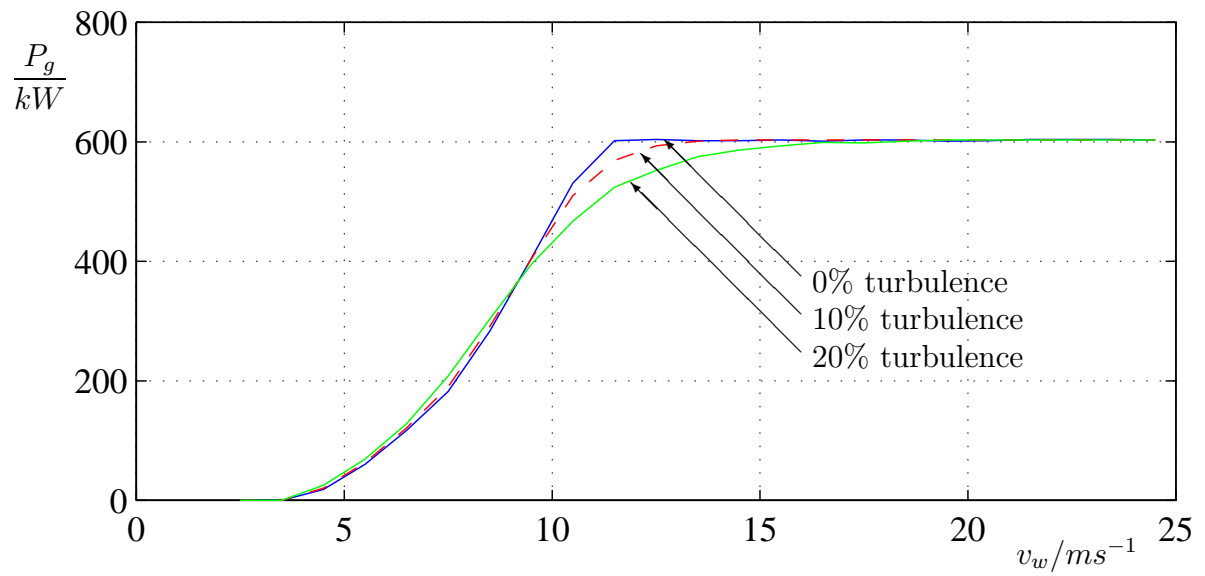

Figure 31: Power curves of the active stall controlled two speed concept

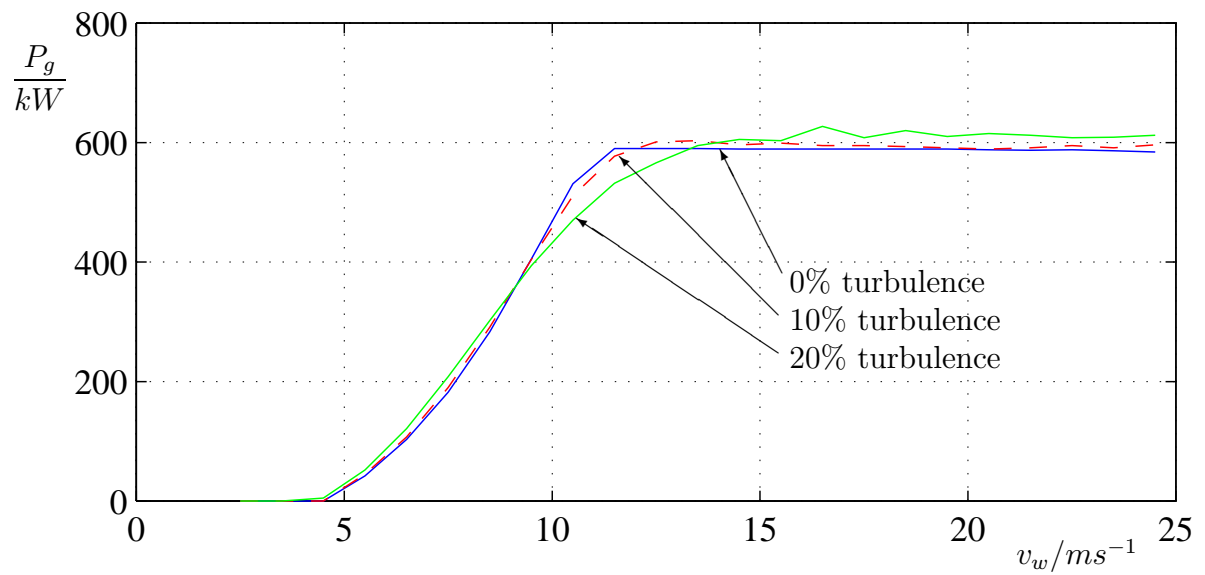

Figure 32: Power curves of the pitch controlled single speed concept

The difference between the pitch controlled single speed concept shown in figure 32 and the pitch controlled two speed concept shown in figure 33 is once more only the higher output power of the latter at low wind speeds. The bad dynamic behaviour at high wind speeds is of course common to both.

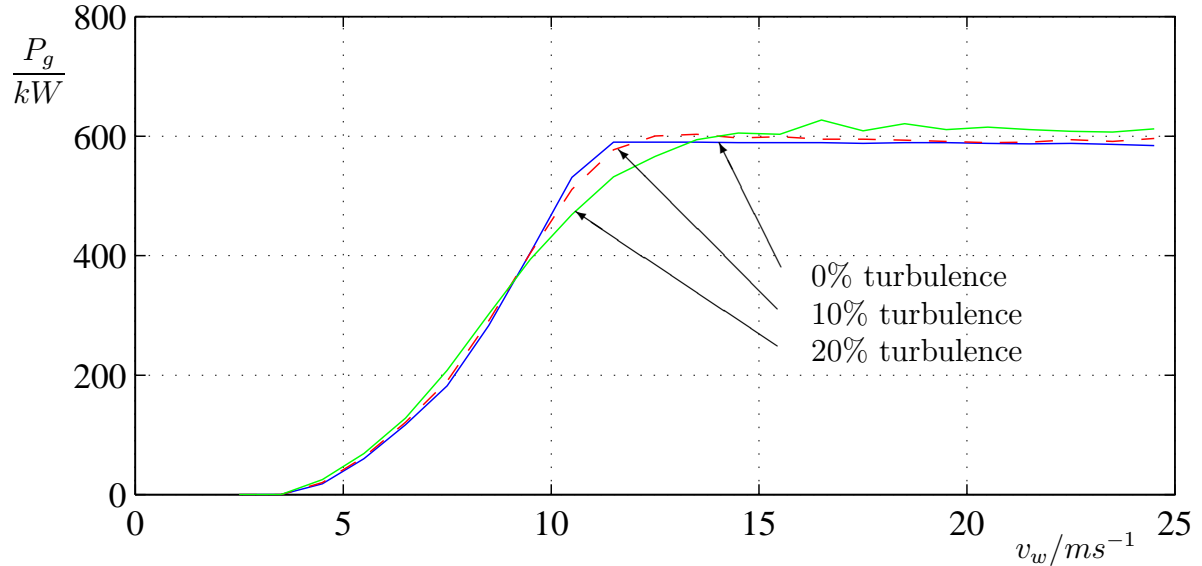

Figure 33: Power curves of the pitch controlled two speed concept

In figure 34, the power curves of the stall controlled variable speed concept are depicted. When compared with the power curves of the fixed speed concepts shown previously, the first and biggest difference is the much higher power production of the variable speed concept at low wind speeds. This is especially true for the 0 turbulence power curve. However, because of the unwanted stalling effect shown in section 5.1, the energy gain resulting from turbulence is lower for the variable speed concept.

The next interesting point is the transition from partial load to full load. Here, the effect of “cutting the edge of the power curve” as shown in figure 8 can be seen clearly in the power curve for 0% turbulence⁵⁰. It is also interesting to see that the power curve for 10% turbulence still shows the cutting of the edge, while the power curve for 20% turbulence doesn’t show it any more. The averaging is now taking place over such a wide area that the effect is smeared so much that it can’t be seen any more.

Finally, the high wind speed region is also interesting, because here it can be seen that the controller is able to keep the reference average power regardless of wind speed and turbulence. This is quite a bit surprising after the rather rough time characteristic presented in section 5.3. However, it shows that the average power can be controlled by using speed variation to control the stall effect.

Last but not least, the power curves for the pitch controlled variable speed concept are shown in figure 35. The low speed behaviour is of course the same as for the stall

⁵⁰The slight curvature in the cutting line results again from the limited horizontal resolution of 1m/s. As the intersection between the cutting line and the rated power line lies a bit to the left of the 12.5m/s point, the theoretically straight line seems to flatten out a bit towards the right.

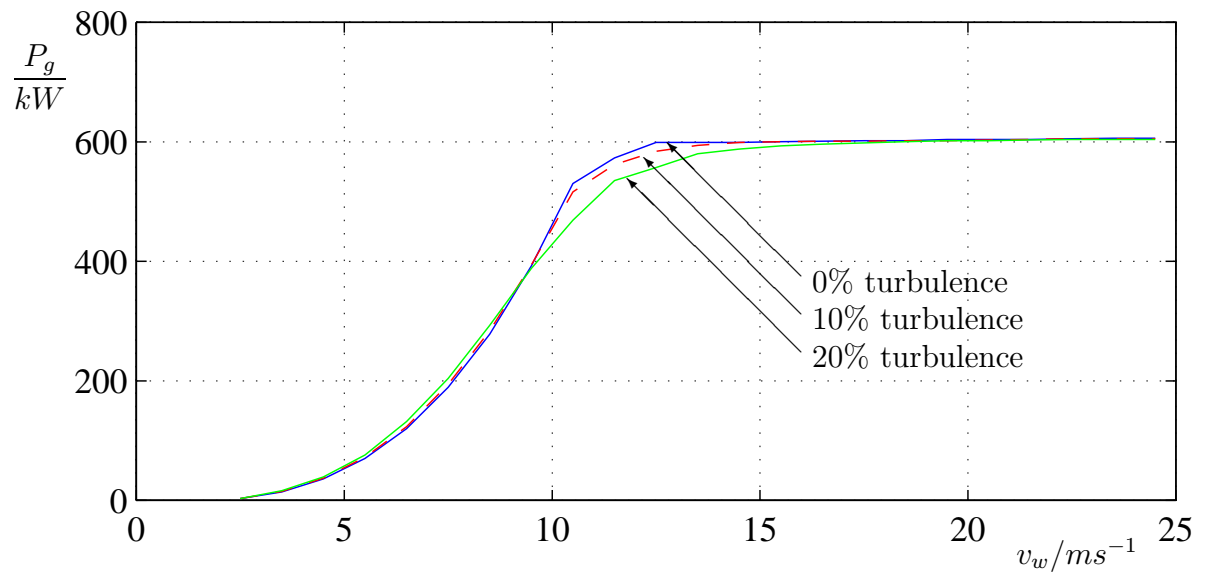

Figure 34: Power curves of the stall controlled variable speed concept

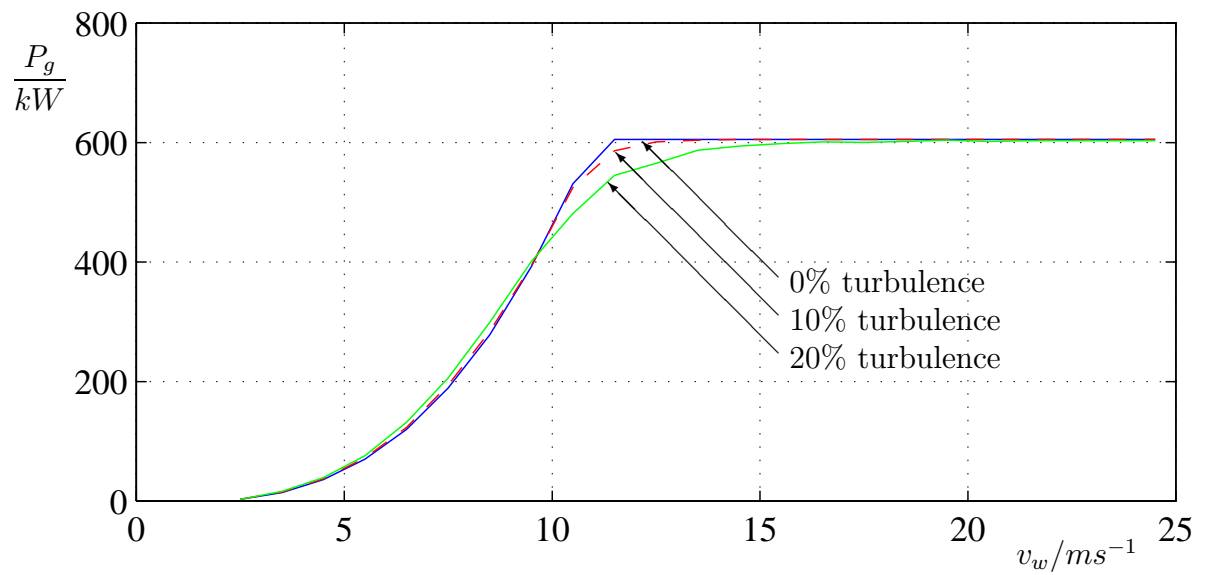

Figure 35: Power curves of the pitch controlled variable speed concept

controlled variable speed concept, because the same controller is used in this region.

Around rated wind speed, the power curve for 0% turbulence looks like the one for pitch or active stall controlled fixed speed concepts. Because of the pitchable rotor blades, no “cutting the edge” is required, which results in a larger area under the power curve and therefore in a higher energy capture, as will be shown later on⁵¹.

Despite this similarity to fixed speed concepts, a close look should be given to the power curve for 20% turbulence. This power curve shows that the output power of the variable speed pitch controlled concept is a bit larger around rated wind speed when compared to fixed speed concepts. This is not the result of a higher system efficiency, but it results from the ability of the variable speed concept to store some energy in the rotor inertia. During wind gusts, the energy is stored by running at a slight overspeed, and it can be used to fill a closely following drop in wind power. Again, this leads to more area under the power curve and therefore to a higher energy capture.

At high wind speeds, the average output power is very well controlled, which is not too surprising after the very smooth time characteristic of the output power shown in section 5.3.

6.2 Influence of the annual mean wind speed

In order to understand the way the following results are presented, first of all the numbering of the individual concepts will be repeated:

Table 10: The numbers of the concepts (repetition of table 1)

	(passive) stall	active stall	pitch
single speed	stall controlled single speed concept 1	active stall controlled single speed concept 3	pitch controlled single speed concept 5
two speed	stall controlled two speed concept 2	active stall controlled two speed concept 4	pitch controlled two speed concept 6
variable speed	stall controlled variable speed concept 7	active stall controlled variable speed concept 8	pitch controlled variable speed concept 8

After this, there are two difficulties which have to be clarified:

- The first one is that there is an inherent limitation in the number of graphs which can be presented here. As the influence of 5 different parameters is to be looked at, and as the system behaviour depends on all parameters in a nonlinear way, it

⁵¹The little “cutting” effect results again from the limited horizontal resolution of the power curve.

would be logical to show one figure for each possible combination of parameters. But even if we would assume only three values for each parameter to be adequate (and for an important parameter like the annual mean wind speed this is certainly not enough), this would lead to $3^5 = 243$ different figures. Such a large amount of graphs would not only make this thesis much thicker than it should be, but it would also be rather confusing.

- The second problem is that the differences of the energy capture between the concepts are rather small. This can be seen in figure 36, which is provided here to show how difficult these small differences are to see and to interpret.

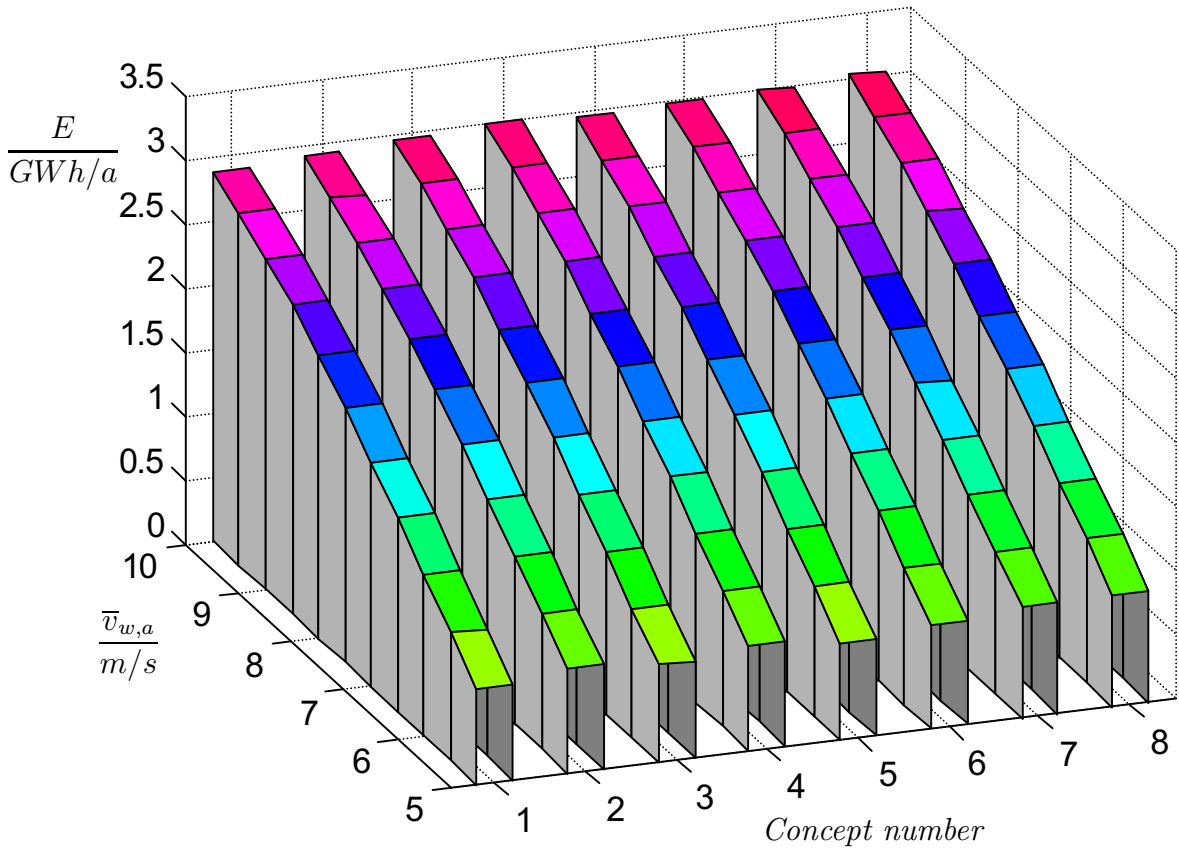

Figure 36: Absolute energy capture of the concepts as a function of $\bar{v}_{w,a}$. Parameters: $k = 2$, $c_{Turb} = 10\%$, $\lambda_D = 6$, profile Goe 758.

As a solution of the first problem, each figure will show the influence of one (or in some cases two) parameters for a special combination of the others. Of course this cannot provide the overview over all possible combinations, but it will show the most interesting effects.

In order to increase the visibility of the differences between the concepts, in the following only these differences will be shown. Therefore, the gain of each concept over the stall controlled single speed concept (which is considered to be the simplest and therefore the reference point) will be shown.

However, even the absolute difference is not the optimum for presentation. If profitability is considered, the relative gain is much more important. A short example will make this clear: If one has the choice between a wind turbine A and another wind turbine B which costs 10% more than A (or, which is the same, which costs the 1.1-fold), then wind turbine B will be more profitable at a certain site if it produces more than 10% more energy than A (or, more than 1.1 times the energy of A). Otherwise, A will be preferable.

For this reason, the relative difference of the energy yield of the wind turbine concepts will be shown here. To achieve this, for each concept the difference between its actual energy capture and the energy capture of the stall controlled single speed concept under *exactly the same combination of parameters* is calculated first. Then, this difference is normalized by dividing it by the latter of the two values. The result is finally presented in percent. This means that the stall controlled single speed concept always has a gain of 0%. The result is figure 37 instead of figure 36.

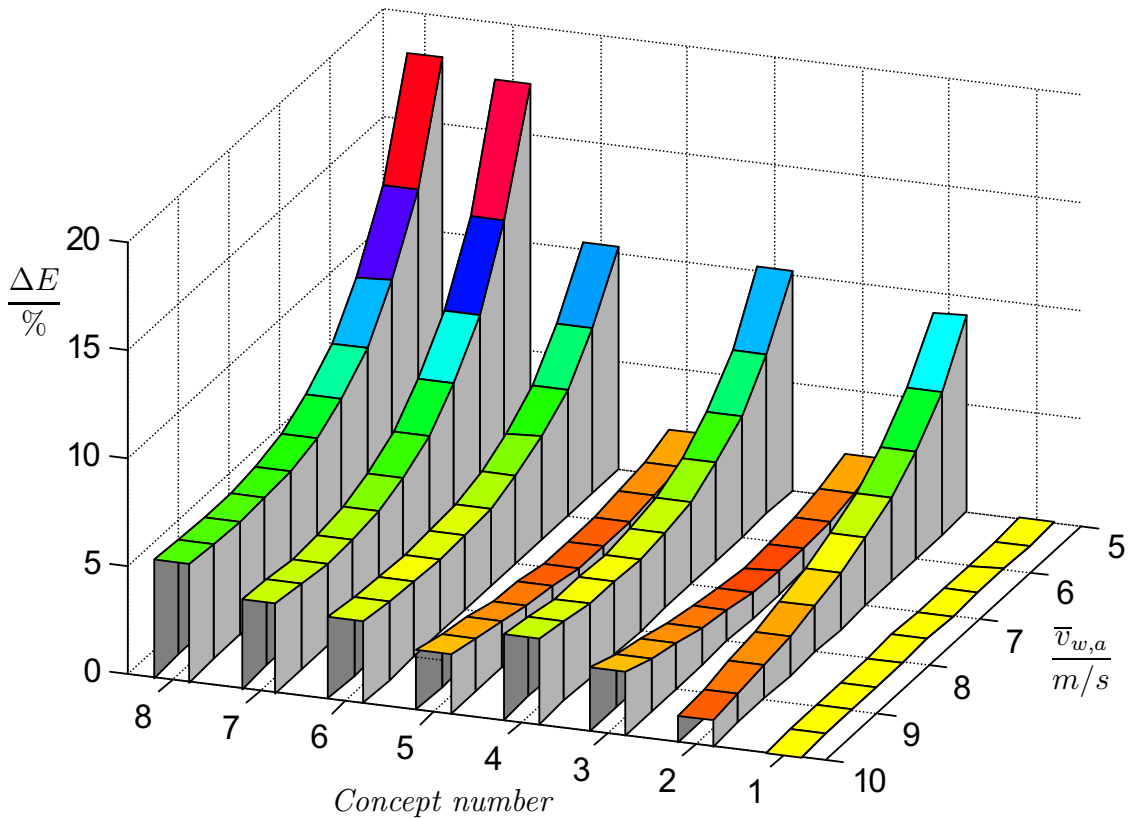

Figure 37: Energy gain of the concepts over concept 1 as a function of $\bar{v}_{w,a}$. Parameters: $k = 2$, $c_{Turb} = 10\%$, $\lambda_D = 6$, profile Goe 758.

It is important to understand this normalization, because nearly all graphs presented in the following use it. It is also the basis of the detailed discussion of all the curves.

Figure 37 shows the energy gain of all concepts over concept 1 as a function of the

annual mean wind speed, while all other parameters are kept at their standard values.

The single speed concepts with active stall (3) and pitch (5) control have rather similar characteristics. This means that at a turbulence level of 10% the difference in dynamic behaviour between the two concepts doesn't show large results regarding energy capture. Both concepts show an increasing energy gain at low as well as at high average annual wind speeds with a minimum in between. The cause for the increase at low wind speeds is the possibility to optimize the power coefficient by turning the blades to an optimum pitch angle in partial load operation. A lower annual mean wind speed increases the weights on these parts of the power curve. On the other hand, high annual mean wind speeds increase the weights on the part of the power curve which lies above rated wind speed. In this part of the power curve, both concepts benefit from their ability to keep rated power, while the power of the stall controlled single speed concepts drops above rated wind speed because of the natural characteristic of the rotor.

The two speed stall controlled concept (2) has its only advantage over concept (1) in its ability to use a lower rotor speed at low wind speeds, which results in an higher energy gain at these wind speeds. Consequentially, it achieves a high gain only for low annual mean wind speeds where there are large weights on the improved parts of the power curve. As the annual mean wind speed becomes higher, the operation time at low wind speeds (in low speed mode) decreases, and therefore the advantage of this concept decreases also to a very low margin at really high annual mean wind speeds.

The two speed active stall controlled (4) and pitch controlled (6) concepts seem to be almost a linear combination of the corresponding single speed concepts (3) and (5) and the two speed stall controlled concept (2). However, their gain is slightly smaller than the sum of the two, especially at low wind speeds. The reason is that the benefit of pitching the rotor blades to their optimum position in partial load operation is reduced by the two speed layout, because in a two speed system the deviation between the actual tip speed ratio and the optimum tip speed ration doesn't become as large as in a single speed system. So the margin for improvements is smaller in two speed systems.

The variable speed concepts with stall (7) and pitch (8) control have an even higher gain than the two speed concepts especially at low annual mean wind speeds, because they are able to adapt much more perfect to the wind speed than their two speed counterparts. With increasing annual mean wind speed their advantage is reduced, because it lies in the low wind speed region (when compared to the active stall and pitch controlled concepts) and a high annual mean wind speed leads to a reduction of the weights on this part of the power curve. The stall controlled variable speed concept has always a slightly lower energy capture when compared to its pitch controlled counterpart because of its need to cut the edge of the power curve around rated power. This disadvantage increases with increasing annual wind speed, as the weights on this part of the power curve are also increased.

6.3 Influence of the annual wind speed distribution

Figure 38 shows the influence of the Weibull shape parameter k on the relative energy capture of the different control concepts. To give an impression of real values for k , reference [15] provides the following sites with their shape parameters: On Heligoland

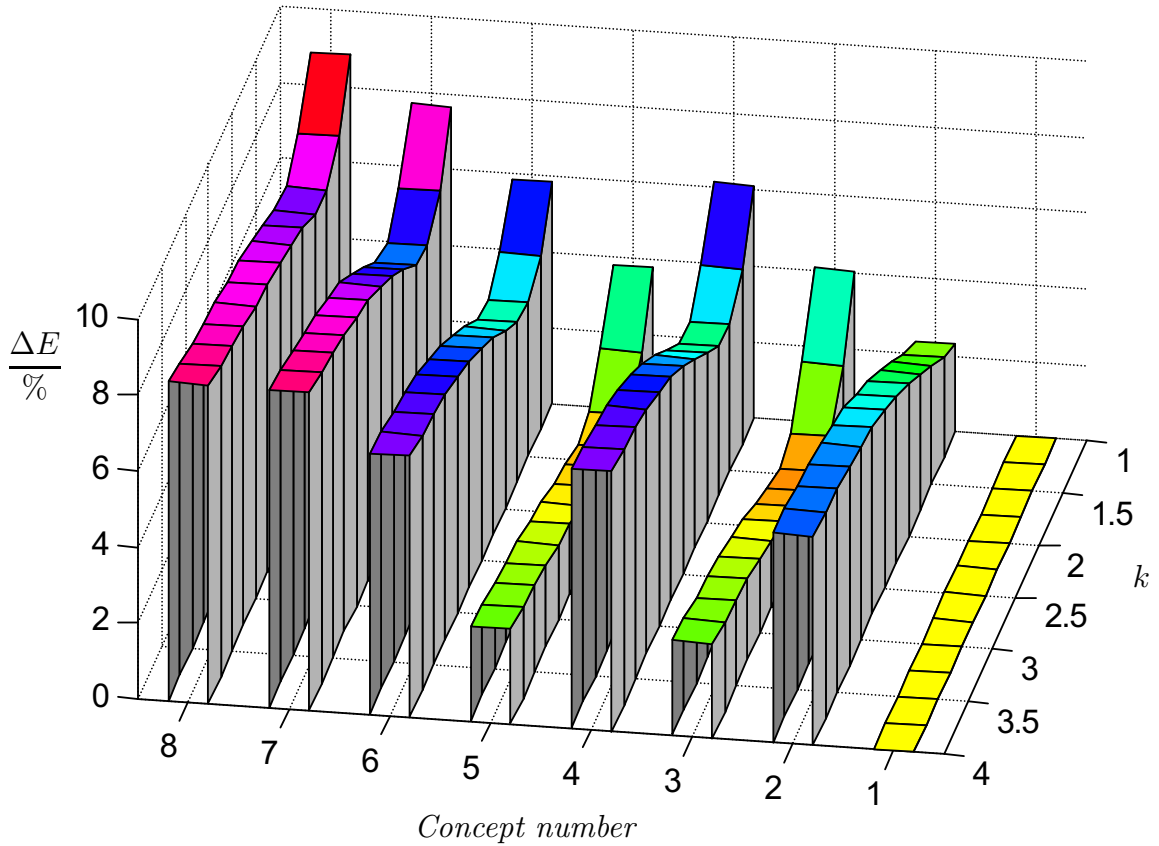

Figure 38: Energy gain of the concepts over concept 1 as a function of k . Parameters: $\bar{v}_{w,a} = 7m/s$, $c_{Turb} = 10\%$, $\lambda_D = 6$, profile Goe 758.

(a small island in the north sea) $k = 2.09$, for Berlin $k = 1.9$ and for Munich $k = 1.28$.

At first glance, the behaviour of the single speed concepts with active stall (3) and pitch (5) control is a bit surprising, as their energy gain is almost independent of the Weibull shape parameter k if the shape parameter is only larger than 2, while for smaller values of k the energy gain increases drastically with descending k . The reason for this behaviour is easily seen with the help of figure 18. If the shape parameter k approaches 1 then the weights on the very low wind speeds *and* on the high wind speeds are strongly increased. As mentioned above, these are the areas where the concepts under consideration have a better performance than the reference concept (1) (due to the pitch optimization in partial load operation and the ability to provide rated power for all wind speeds above rated wind speed). As will be explained in the next paragraph, the increase at low wind speeds does not provide a large increase in energy gain, which can also be seen in the behaviour of the stall controlled two speed concept (2). However, the increased weights on high wind speeds lead to the observed increase in energy gain.

The stall controlled two speed concept (2) shows a slight decrease in energy gain with decreasing shape parameter k . To explain this behaviour, figure 18 must be looked

at again. There it can be seen that with decreasing shape parameter the weight on the very low wind speeds increases, but there is also an interval between roughly $0.7\bar{v}_{w,a}$ and $1.5\bar{v}_{w,a}$ in which the weight decreases. For an average wind speed of $7m/s$, this interval extends between $\approx 5m/s$ and $\approx 10m/s$, which contains a large part of the interval in which the two speed concept is superior to the single speed concept when one looks at the power curves in section 6.1. The decreasing weight on this interval is the reason for the decreasing energy gain at low values of k in spite of the increasing weights at lower wind speeds.

The two speed active stall (4) and pitch (6) controlled concepts again show a behaviour similar to the sum of their respective single speed counterparts and the two speed passive stall controlled concept. The reason why they don't reach a gain which is exactly the addition of the gains of the underlying concepts has already been discussed in the description of figure 37 and therefore doesn't have to be repeated here.

The behaviour of the variable speed concepts (7,8) is rather close to those of the two speed concepts. Especially the stall controlled variable speed concept (7) simply has an almost constant gain over the pitch controlled two speed concept. This gain is the result of its better ability to adapt to the wind speed. The pitch controlled variable speed concept (8) does not only have another slight gain (because there is no need to cut the edge of the power curve in this concept), but it also doesn't have the slight dip around a shape parameter of 1.5.

In the following, the influence of the annual mean wind speed and the form parameter on the energy gain will be shown for only one concept per figure, but therefore as a function of both parameters at the same time. The reason is that in reality sites with a rather high annual mean wind speed (e.g. offshore sites) tend to have a larger shape parameter, while interior sites with low annual mean wind speeds tend to have a smaller shape parameter[15]⁵². Of course there is also a dependence between the annual mean wind speed and the turbulence, but unfortunately it is not possible to show the energy capture as a function of more than two variables at the same time.

However, not all concepts will be shown individually. As mentioned above, the behaviour of the two speed active stall and pitch controlled concepts are almost a linear combination (i.e., the sum) of the behaviours of their respective single speed variants and the passive stall controlled two speed concept⁵³. Therefore, the two speed variants of the active stall controlled and the pitch controlled concept will not be shown in a separate diagram here.

First, as the basis of the whole comparison, the absolute energy capture of the stall controlled single speed concept is shown in figure 39.

As expected, the annual energy capture increases with increasing annual mean wind speed. However, the amount of this increase depends largely on the shape parameter. While for small annual mean wind speeds a small shape parameter leads to a higher annual energy capture, the opposite is true for large annual mean wind speeds. This

⁵²This is probably due to the higher roughness of the terrain often found in the vicinity of sites with lower annual average wind speeds. This roughness of course creates a higher turbulence, but as it seems it has also an impact on the shape parameter in the direction that larger variations in wind speed are more probable, which leads to a smaller shape parameter.

⁵³Although their energy gain is always a bit smaller than the sum as discussed above. However, the dependence on the parameters under consideration is like that of the sum of the two.

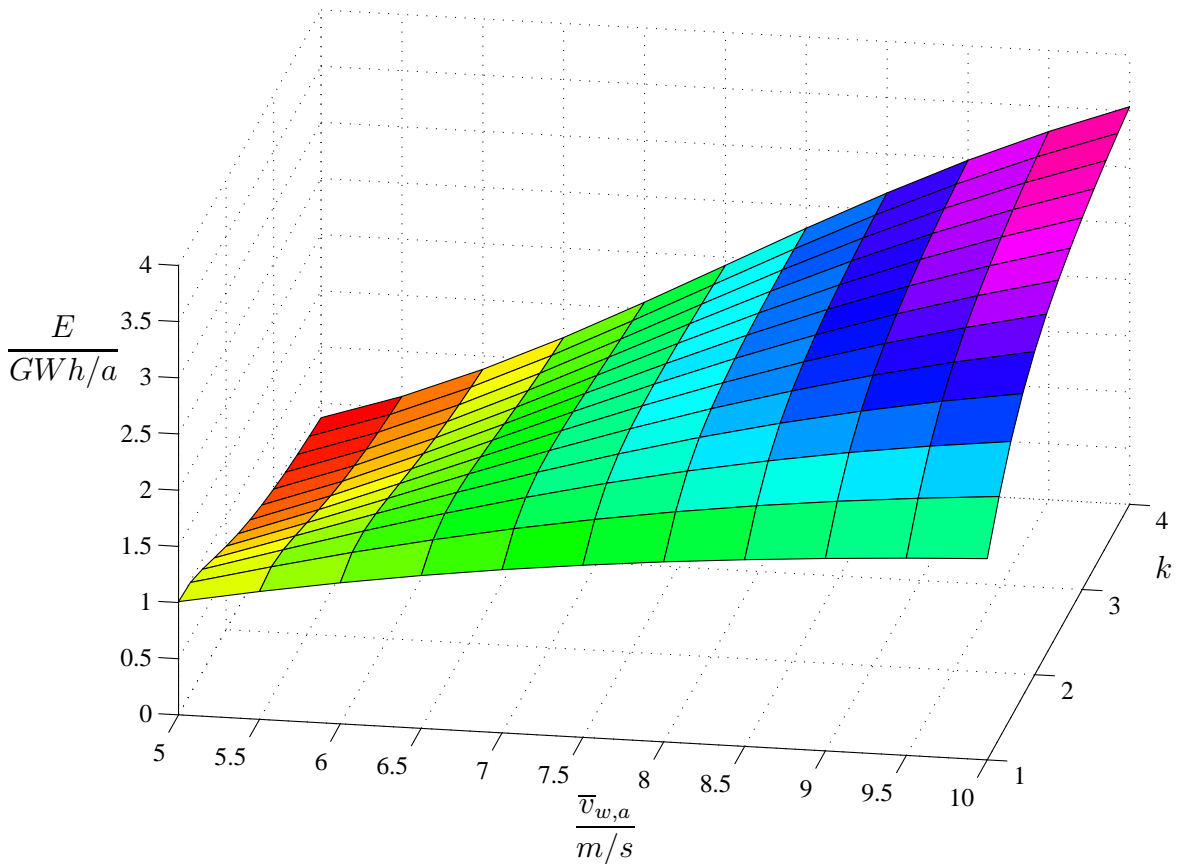

Figure 39: Absolute energy capture of the concept 1 as a function of $\bar{v}_{w,a}$ and k . Parameters: $c_{Turb} = 10\%$, $\lambda_D = 6$, profile Goe 758.

is of course an advantage for wind turbines in general, as it helps in making good use of each annual mean wind speed by using the above mentioned correlation with the shape parameter.

It also shows up that the increase in energy capture with wind speed is in no way proportional to the third power of the wind speed, as is the power inherent in the wind. The reason for this is of course the limitation of the wind turbine, which is not able to produce more than its rated power. It can also be seen that for small shape parameters the increase of the annual energy capture is even slower than linear. In contrast, for large shape parameters the increase in annual energy capture is faster than linear for small annual mean wind speeds and almost linear for large wind speeds.

Further, the very small energy captures for the (rather unrealistic) combinations of a small annual mean wind speed and a larger shape parameter must be noted, as this small capture is one reason for the huge (and completely unrealistic!) gains of some of the other concepts shown in the next figures.

For all following figures it should be noted that the comparisons shown in the figures 37 and 38 might be seen as a collection of cuts through the figures of all individual concepts. The cut for figure 37 would be along the line $k = 2$, while the cut for figure

38 would be along the line $\bar{v}_{w,a} = 7\text{m/s}$.

The first of these, figure 40, shows the energy gain of the stall controlled two speed concept over its single speed counterpart.

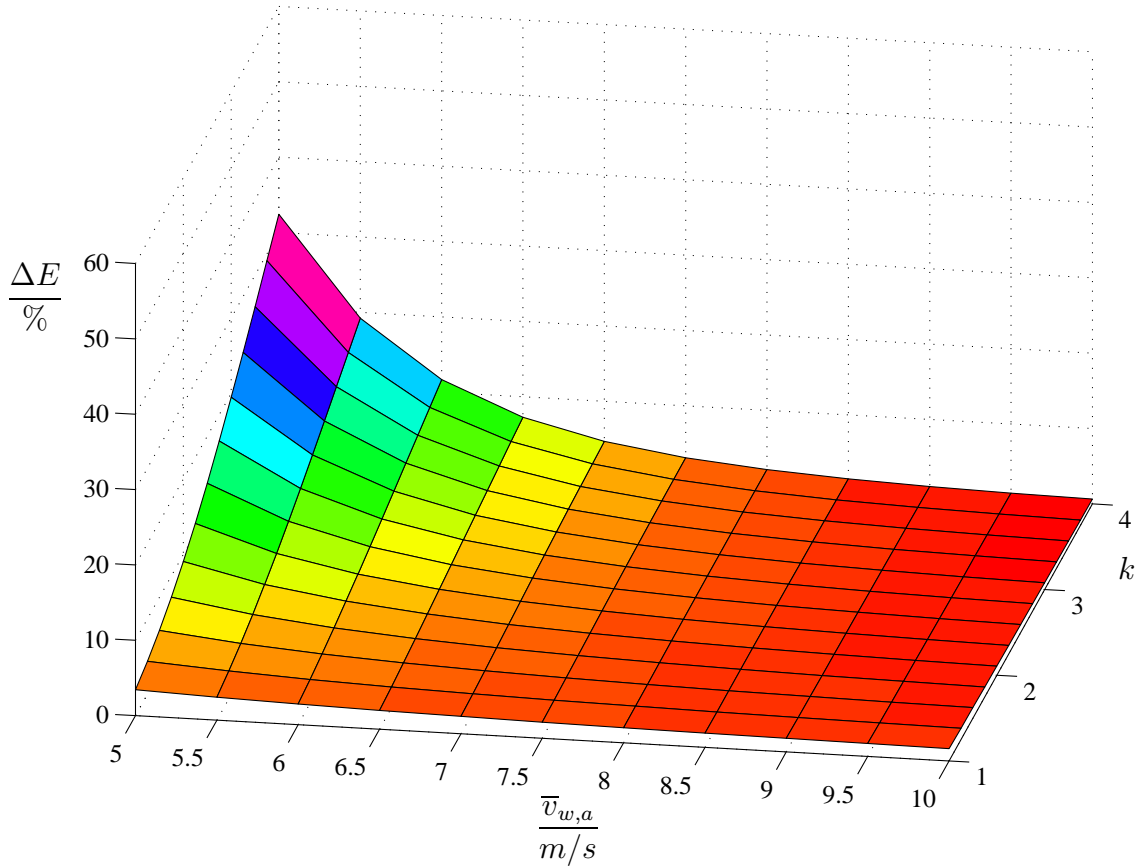

Figure 40: Energy gain of the concept 2 over concept 1 as a function of $\bar{v}_{w,a}$ and k . Parameters: $c_{Turb} = 10\%$, $\lambda_D = 6$, profile Goe 758.

The first thing to note is the large gain for a combination of low annual mean wind speeds and large shape parameters, which is unrealistic as sites with these conditions probably don't exist.

The next point to mention is that the generally positive feature of the stall controlled single speed concept, that its characteristic makes good usage of each annual mean wind speed by the correlated shape parameter, reduces the advantage of the two speed concept. It can clearly be seen that for low annual mean wind speeds the minimum of energy gain is at low shape parameters, which are likely to be found here, while for high annual mean wind speeds the minimum energy gain occurs at high shape parameters, which are also likely to be found here.

Generally speaking (and a bit drastic), one could also say that the natural characteristics lead to a minimization of the gains of more advanced control systems.

Figure 41 shows the same as before, but for the active stall controlled single speed concept.

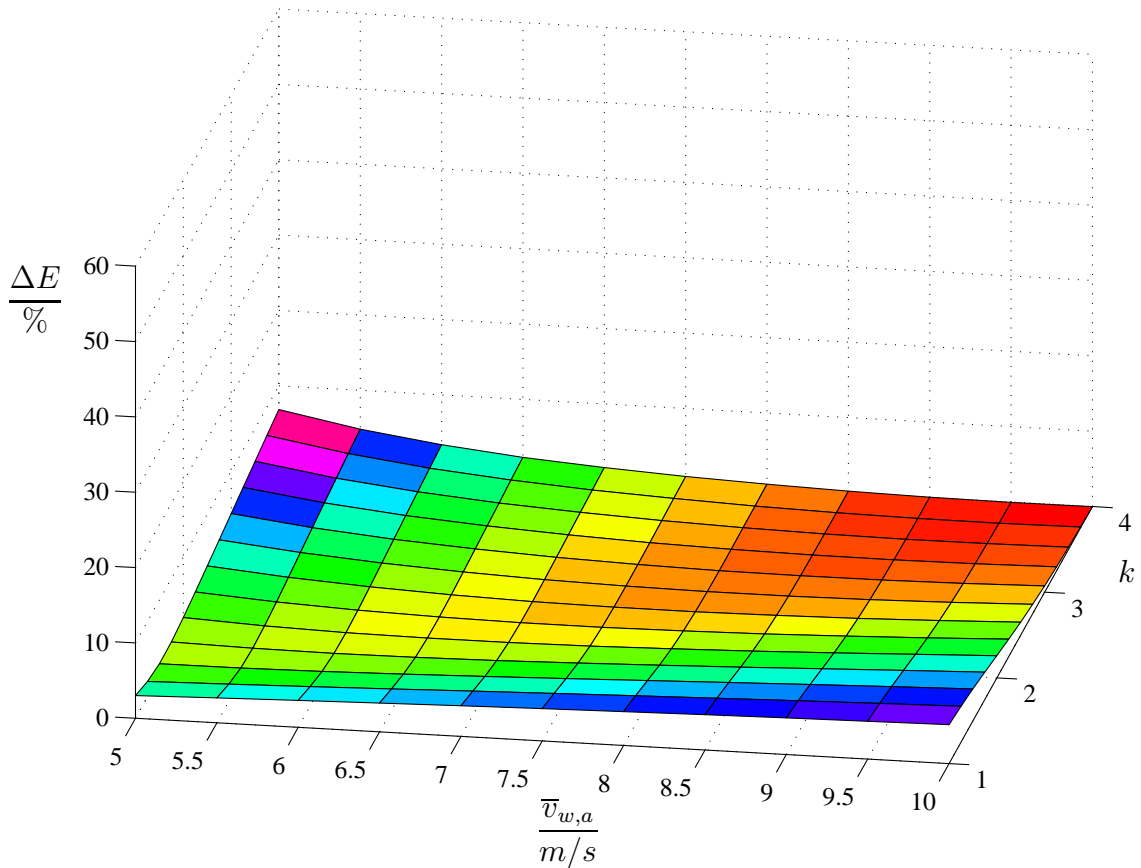

Figure 41: Energy gain of the concept 3 over concept 1 as a function of $\bar{v}_{w,a}$ and k . Parameters: $c_{Turb} = 10\%$, $\lambda_D = 6$, profile Goe 758.

It can be seen that the dependence of the general energy gain on the parameters is much lower. But still, there is a minimum in gain for each annual mean wind speed. And again it lies at low shape parameters for low annual mean wind speeds and at high shape parameters for high annual mean wind speeds, which means that it is again probable that these minima are hit by realistic site conditions.

But regardless of site conditions, the gain by the two advantages of this concept (pitching the blades to an optimum angle below rated wind speed and keeping rated power for all wind speeds above rated wind speed) is not more than a few percent⁵⁴.

As figure 42 shows, exactly the same is true for the pitch controlled single speed concept, although there are slight variations between the exact amount of energy gain between this concept and the active stall controlled one.

These very small variations are due to the different dynamic responses of the two concepts which show up around and above rated wind speed (see sections 5.2 and 6.1 for details). The slower response of the pitch controlled concept leads to a slightly different energy production especially at high average wind speeds and at low shape

⁵⁴The scale of the vertical axis has been chosen to be the same for all figures from 39 to 44 in order to make comparisons easier.

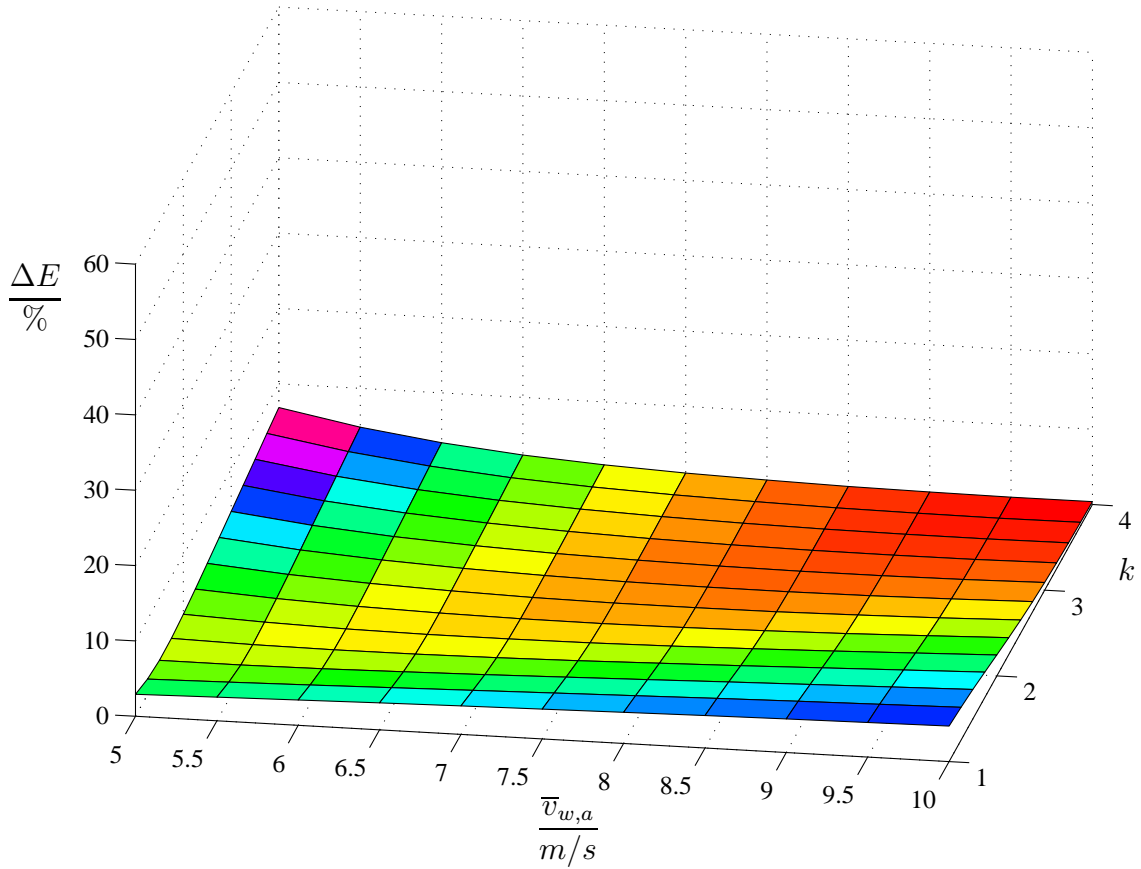

Figure 42: Energy gain of the concept 5 over concept 1 as a function of $\bar{v}_{w,a}$ and k . Parameters: $c_{Turb} = 10\%$, $\lambda_D = 6$, profile Goe 758.

parameters, as these conditions put an increased weight on the wind speeds much above rated wind speed.

Things are again looking much different when it comes to variable speed concepts. Figure 43 shows the gain in energy capture for the stall controlled variable speed concept, and it can be seen that this time there is again a large peak in the gain in energy over concept 1 for small annual mean wind speeds and large shape parameters. In fact, this peak is even much higher than for the stall controlled two speed concept shown in figure 40. But again, these are no realistic site conditions and therefore these large gains cannot be realized.

Again for each annual mean wind speed, there is a minimum of gain. And unfortunately also again, these minima lie on the side of low shape parameter for low annual mean wind speeds and at high shape parameters for high annual mean wind speeds, which makes it likely that most sites lie within these minima.

Another interesting point worth mentioning is that if the Weibull shape parameter is low then the energy gain of this concept is almost independent of the annual average wind speed.

What should also be noted is the extreme difference in energy gains depending

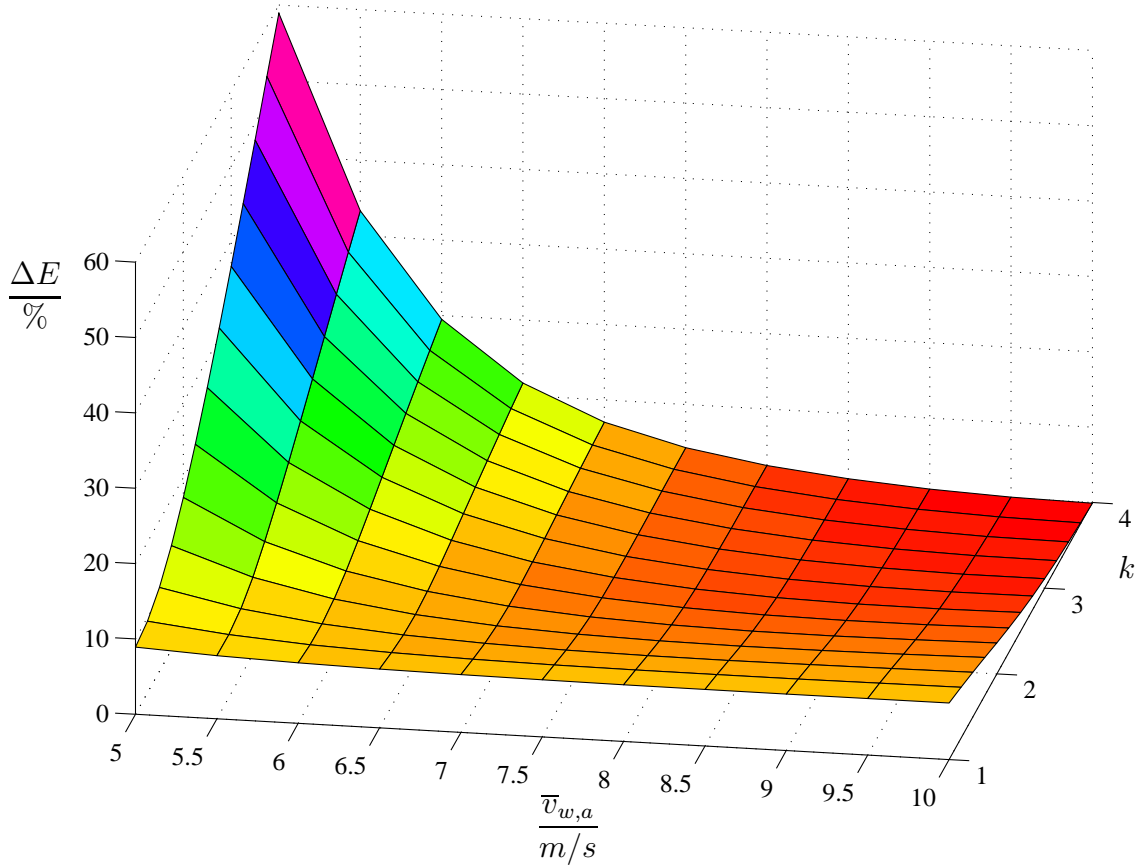

Figure 43: Energy gain of the concept 7 over concept 1 as a function of $\bar{v}_{w,a}$ and k . Parameters: $c_{Turb} = 10\%$, $\lambda_D = 6$, profile Goe 758.

on these two parameters. As a shape parameter of $k = 4$ might not be realistic, let's assume a maximum realistic shape parameter of $k = 3$. Even for this value, the energy gain of this variable speed stall controlled concept over the stall controlled single speed concept can range from a minimum of $\approx 2\%$ at an annual mean wind speed of $\bar{v}_{w,a} = 10m/s$ up to a maximum of $\approx 35\%$ percent at an annual mean wind speed of $\bar{v}_{w,a} = 5m/s$, depending only on the annual average wind speed. Therefore, if no exact parameters are given, almost any result can be obtained⁵⁵.

The last concept which has to be looked at is the pitch controlled variable speed concept. The gain of this concept is depicted in figure 44. This figure looks very similar to the stall controlled variable speed concept shown in figure 43. Almost all of the facts stated there are also applicable here, especially that realistic site conditions lead always to a minimum energy gain and that the energy gain is almost independent of the annual average wind speed if the shape parameter is small.

However, there is also a difference in figure 44 which may be noted at second glance:

⁵⁵And even if it has nothing to do with the scientific nature of this study it should be mentioned that especially any *wanted* result can be produced by choosing simply the right site conditions (i.e. the right parameters for the simulation) to provide this result.

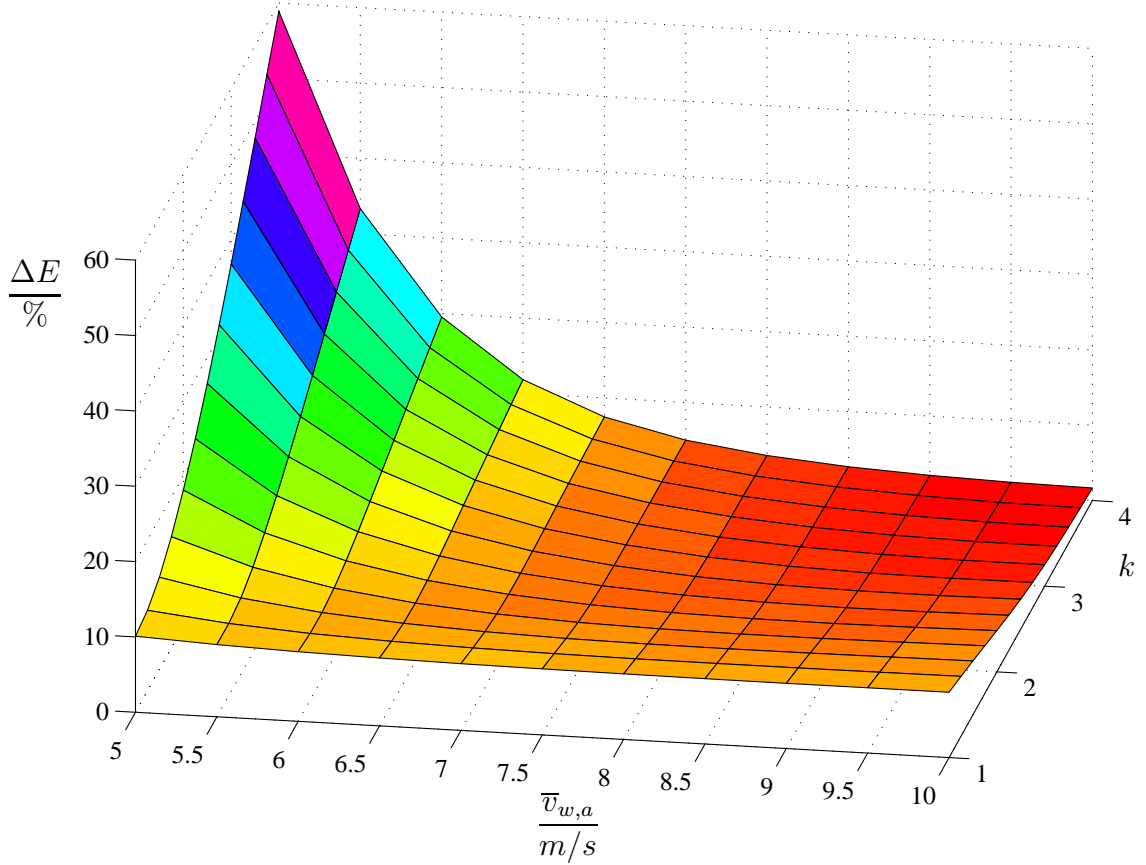

Figure 44: Energy gain of the concept 8 over concept 1 as a function of $\bar{v}_{w,a}$ and k . Parameters: $c_{Turb} = 10\%$, $\lambda_D = 6$, profile Goe 758.

While the peak for low annual mean wind speed and large shape parameter is of the same height as in figure 43, the borders at large shape parameters and high annual mean wind speeds show a slightly larger energy gain for these conditions. The reason is that these conditions (at the mentioned borderlines) put sufficient weight on the part of the power curve just around rated power, where the pitch controlled concept has its advantage over the stall controlled one. In contrast, figure 18 shows that for the conditions at the top of the peak ($\bar{v}_{w,a} = 5m/s$ and $k = 4$), there is almost no weight on anything above a wind speed of $9m/s$. Therefore, there is no difference in energy gain between the two variable speed concepts here.

6.4 Influence of the turbulence

The influence of the turbulence on the energy capture is shown in Figure 45. As only the relative energy gain of the different concepts is shown, it might be interesting to know that the absolute energy capture of the reference concept (1) falls with increasing turbulence.

The values given for 0 turbulence are “ideal” values, which would also have been

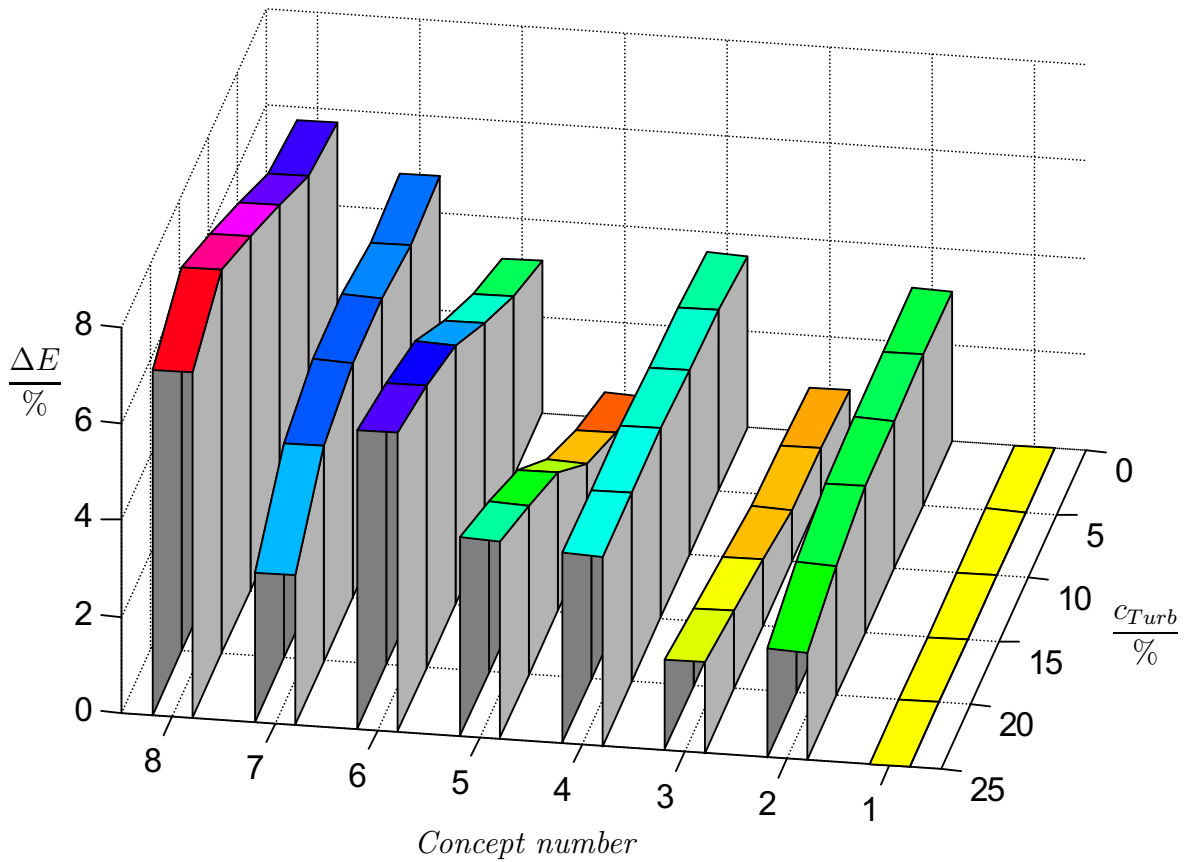

Figure 45: Energy gain of the concepts over concept 1 as a function of c_{Turb} . Parameters: $\bar{v}_{w,a} = 7m/s$, $k = 2$, $\lambda_D = 6$, profile Goe 758.

the result if one would have done only steady-state calculations. The very different behaviour of the different concepts calls for a detailed discussion here.

The first point to note is that the energy gain of the active stall controlled single speed concept (3) is almost independent of the turbulence. This is caused by the excellent dynamic behaviour of this concept.

However, things are much different for the pitch controlled single speed concept (5), as it shows a rather large increase in energy capture with increasing turbulence level. The reason is that the control of this concept is rather slow, as was already seen in section 5.2. As depicted there, this concept is sometimes not able to limit the output power fast enough when operating around rated wind speed. Instead, for some time intervals overpower is produced, which of course contributes to the annual energy capture and leads to this increase in energy gain. However, this is not something to be regarded as positive, because in fact the turbine feeds more than its rated power into the grid, which is not what it should do. Furthermore, this overpower also poses high mechanical stress on many components, like rotor blades and gearboxes, and it may overload the generator, too. So it is something not really wanted.

The stall controlled two speed concept (2) has an almost constant energy gain, which

drops only slightly at high turbulence levels. The reason is that high turbulence can lead to rather high peaks in the wind speed while the turbine is in low speed operation mode. These high peaks are able to stall the turbine rotor at low speed operation so that energy is lost which can be captured by a single speed turbine because its rotor is always at full speed.

In contrast, the active stall controlled two speed concept (4) can avoid this energy loss because of its ability to pitch the rotor blades always to their optimum angle, which is used here to avoid stalling the rotor at low rotational speed⁵⁶.

The pitch controlled two speed concept (6) shows a combination of the characteristics of the concepts (2) and (5). All the comments made on the drawbacks of the increased energy gain at high turbulence made for concept (5) also apply to this concept.

The energy gain of the stall controlled variable speed concept (7) drops with increasing turbulence. The reason is that when the turbine is in partial load operation and the rotor is slow, then the wind speed can increase faster than the rotor speed is able to follow, which results in stalling the rotor and a loss of energy. This phenomenon was already discussed in section 5.1 in more detail. Its influence increases with increasing turbulence, of course, and causes thereby the drop in energy gain.

However, the pitch controlled concept (8) doesn't show the same behaviour, at least not for low levels of turbulence, which means that the underlying effect must be compensated by something else. The reason is that around rated wind speed, this concept suffers from the same dynamic control problems as the pitch controlled concepts (5) and (6). However, the concept (8) doesn't have to feed the additional power during wind gusts into the grid as overpower, but instead it can store it in the rotor inertia by an increase in rotor speed. If a drop in wind speed follows soon after (before the rotor speed controller has slowed the rotor down to its rated speed), then the energy stored in the rotor can be fed into the grid. So this concept is able to use the overpower without letting the grid see it. However, at very high turbulence levels the effect of stalling the rotor in partial load operation as described for concept (7) cannot be compensated and a loss of energy gain occurs.

From figure 45 it can be seen that the energetic advantage of the pitch controlled variable speed concept (8) over its two speed counterpart (6) decreases with increasing turbulence. As it also decreases with increasing annual mean wind speed (shown in figure 37), the question arises whether there is a crossover point. And, as figure 46 shows, there really is one.

In figure 46 this crossover point seems to be at $\approx 20\%$ of turbulence (and an annual mean wind speed of $\bar{v}_{w,a} = 9m/s$, of course, as figure 46 is plotted for this value). Figure 46 also shows that the general behaviour of the different control concepts is not far apart from their behaviour at an annual mean wind speed of $\bar{v}_{w,a} = 7m/s$ as in figure 45 while the absolute values are different, of course. The only slight exception from this similar behaviour is that the energy gain of the pitch controlled single speed (5) and two speed (6) concepts increases even stronger than in figure 45. The reason for this is that a higher annual mean wind speed puts larger weights on the interval

⁵⁶However, this might cause unwanted overpower of the small generator during wind gusts, which can be avoided in a real system by modifying the pitch angle vs. power characteristic appropriately, but at the expense of losing this energy.

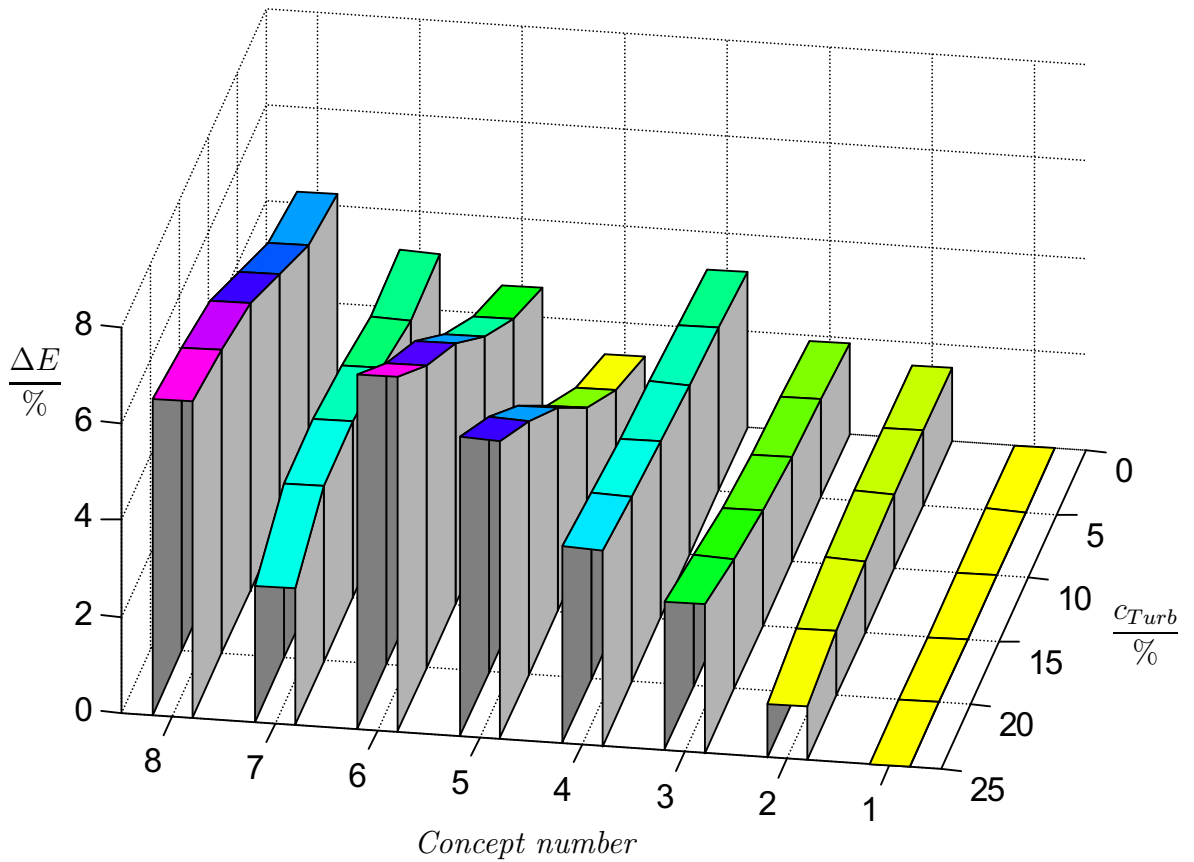

Figure 46: Energy gain of the concepts over concept 1 as a function of c_{Turb} . Parameters: $\bar{v}_{w,a} = 9m/s$, $k = 2$, $\lambda_D = 6$, profile Goe 758.

around rated wind speed where the overpower shows up.

In order to show not only one point of crossover as in figure 46, it is of course possible to plot the gain of the variable speed pitch controlled concept over its two speed counterpart as a function of both annual mean wind speed and turbulence, which has been done in figure 47.

As expected, the largest gains with variable speed are achieved at low annual mean wind speeds. With increasing annual mean wind speed, the advantage of variable speed drops first quickly and then flattens out above $6m/s$. But the influence of turbulence remains almost unchanged⁵⁷, which causes the curves of equal advantage to change their direction. It can be seen that the curve of the same energy production (0%) runs from an annual mean wind speed of $7.9m/s$ and a turbulence of 25% to $10m/s$ and 17%.

⁵⁷While the figure at first glance suggests something different, it can be seen that changing the turbulence from 0% to 25% at an annual mean wind speed of $5.1m/s$ changes the advantage from 7% to a bit more than 5%. Doing the same increase in turbulence at $7.8m/s$ annual mean wind speed leads to a decrease from 2% to a bit more than 0%. So it can be seen that the same increase in turbulence leads to the same reduction in advantage.

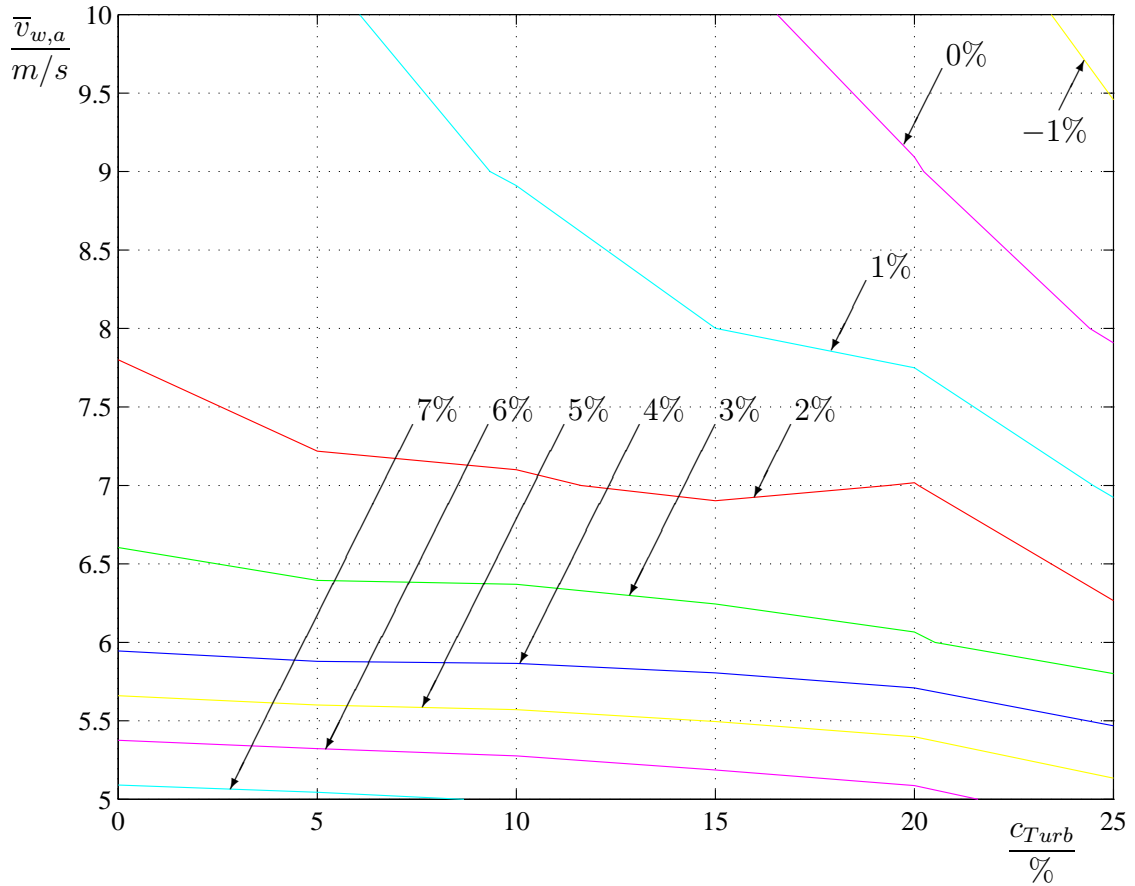

Figure 47: Energy gain of the concept 8 over concept 6 as a function of $\bar{v}_{w,a}$ and c_{Turb} . Parameters: $k = 2$, $\lambda_D = 6$, profile Goe 758.

However, the important point here is that this line of equality exists, not at which exact conditions it occurs. As was said before, this study is intended to be qualitative rather than quantitative. As the advantage of complicated control strategies is usually overestimated by simulations because of the neglect of many small influences, it is likely that the line of zero advantage lies more to the left and lower than figure 47 shows. This opinion is also strengthened by the results shown in reference [5].

6.5 Influence of the design tip speed ratio

This section has been mainly provided because during the discussion of special offshore wind turbines, there was the proposition to increase the design tip speed ratio of these turbines in [27]. This would lead to a lower torque and therefore to a lighter construction. The drawback of a higher tip speed ratio, which is more noise, is not so problematic in offshore use.

The influence of the design tip speed ratio on the relative energy capture is shown in figure 48. In order to be able to interpret the results better, it might be interesting to know that the energy capture of the single speed stall controlled reference concept

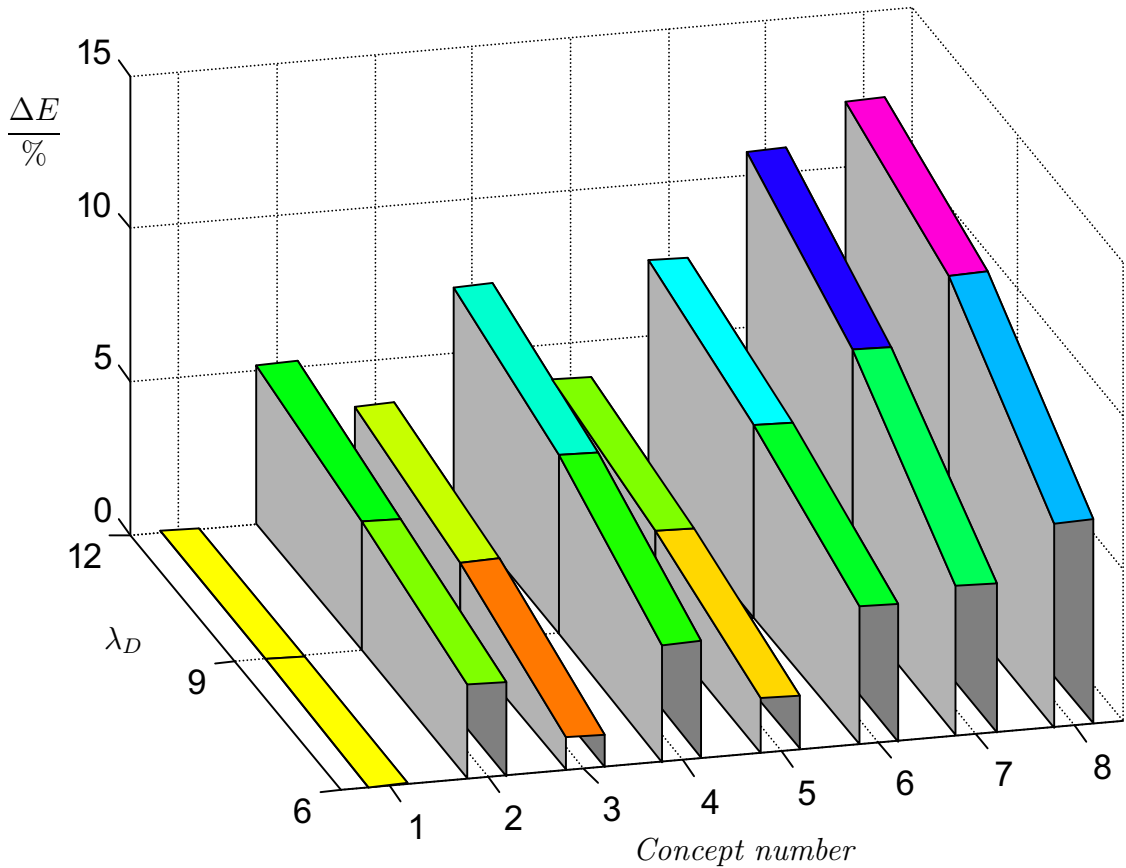

Figure 48: Energy gain of the concepts over concept 1 as a function of λ_D . Parameters: $\bar{v}_{w,a} = 7\text{m/s}$, $k = 2$, $c_{Turb} = 10\%$, profile Goe 758.

(1) drops with increasing design tip speed ratio. The reason is mainly that the tip losses were not modeled in the blade element model used for the simulations, as vortex shedding cannot easily be included in a blade element model⁵⁸.

It can be seen that the energy gain of all concepts over the reference concept (1) increases with increasing design tip speed ratio. This means that the higher the design tip speed ratio, the more will the complicated concepts pay off.

The reason for this behaviour is that the rotor characteristic of a rotor designed for a higher design tip speed ratio becomes “sharper”, which means that the band of the tip speed ratios in which high power coefficients are produced becomes relatively narrower. Therefore, a rotor running at one or two fixed speeds loses more energy than it does with a broader rotor characteristic at a lower design tip speed ratio.

However, while figure 48 seems to point clearly in the direction of variable speed

⁵⁸The method described in [15] by reducing the diameter depending on the design tip speed ratio and the number of rotor blades has not been implemented. The reason is that this method uses only design parameters to calculate the reduced diameter. Therefore, it would have exactly the same influence on the power produced by all concepts at each design tip speed ratio, which means that it wouldn't have any influence on the relative energy gain of one concept over another one.

for higher design tip speed ratios, once more things are not so simple. As these high speed concepts are intended for offshore use, they will run at higher annual mean wind speeds, and as figure 49 shows, the energy gain still drops for higher annual mean wind speeds. So at least a part of the increased advantage of sophisticated concepts gained by higher design tip speed ratios will be eaten up by the also increased annual mean wind speed of the offshore sites.

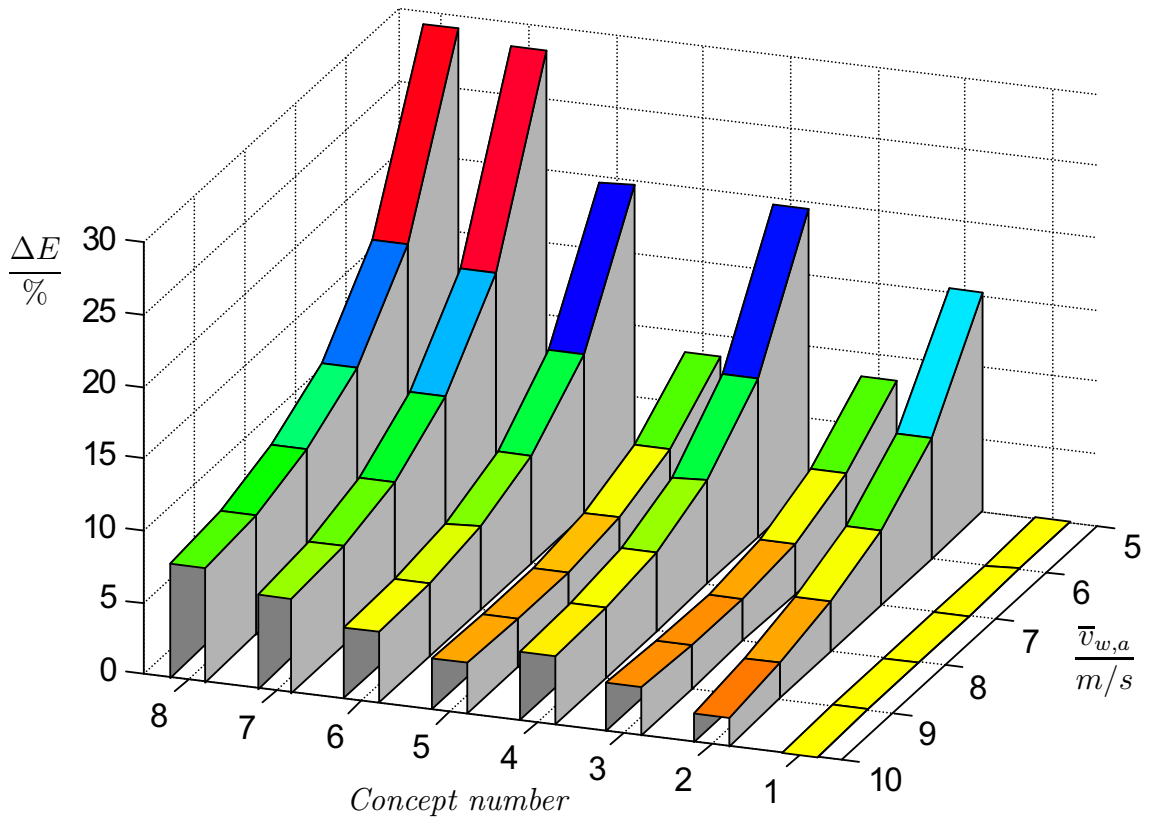

Figure 49: Energy gain of the concepts over concept 1 as a function of $\bar{v}_{w,a}$. Parameters: $k = 2$, $c_{Turb} = 10\%$, $\lambda_D = 12$, profile Goe 758.

When comparing figure 49 to figure 37, at first glance the figures look very similar. However, the scale of the gain is different, so that the gains of all concepts are much higher in figure 49.

Another interesting point is that the single speed concepts with active stall (3) and pitch (5) regulation don't show the typical minimum in gain seen in figure 37 any more. The reason is that the partial load behaviour of the reference concept (1) is much worse (as was already said above). Therefore, the energy gain in the low wind speed portion of the power curve possible by pitching the rotor blades to their optimum pitch angles has increased a lot. This means that the benefits at low wind speeds are much bigger than the benefits at high wind speeds from always operating at rated power. Therefore, putting bigger weights on the low speed portion of the power curve (i.e. reducing the annual mean wind speed) increases the relative energy gain.

Finally, it should be noted that the energy gain of the variable speed concepts has improved much. This is not so natural as it first might seem, as an increase in design tip speed ratio means that all rotor speeds are increased while all rotor torques are reduced. Therefore, the problem of following the wind speed with the rotor speed during wind gusts becomes more difficult, which will definitely increase the energy losses produced by stalling the rotor during wind gusts. The only possible answer to this is that the fixed speed concepts loose even more energy due to the sharp rotor characteristic.

Figure 50 shows the influence of turbulence for a high design tip speed ratio. When comparing it to figure 45, the first interesting point is that with a high design tip speed ratio the pitch controlled single speed and two speed concepts show the same behaviour which the active stall controlled ones have already shown at a low design tip speed ratio. This indicates that the dynamic performance of the pitch controller has improved due to the sharper rotor characteristic.

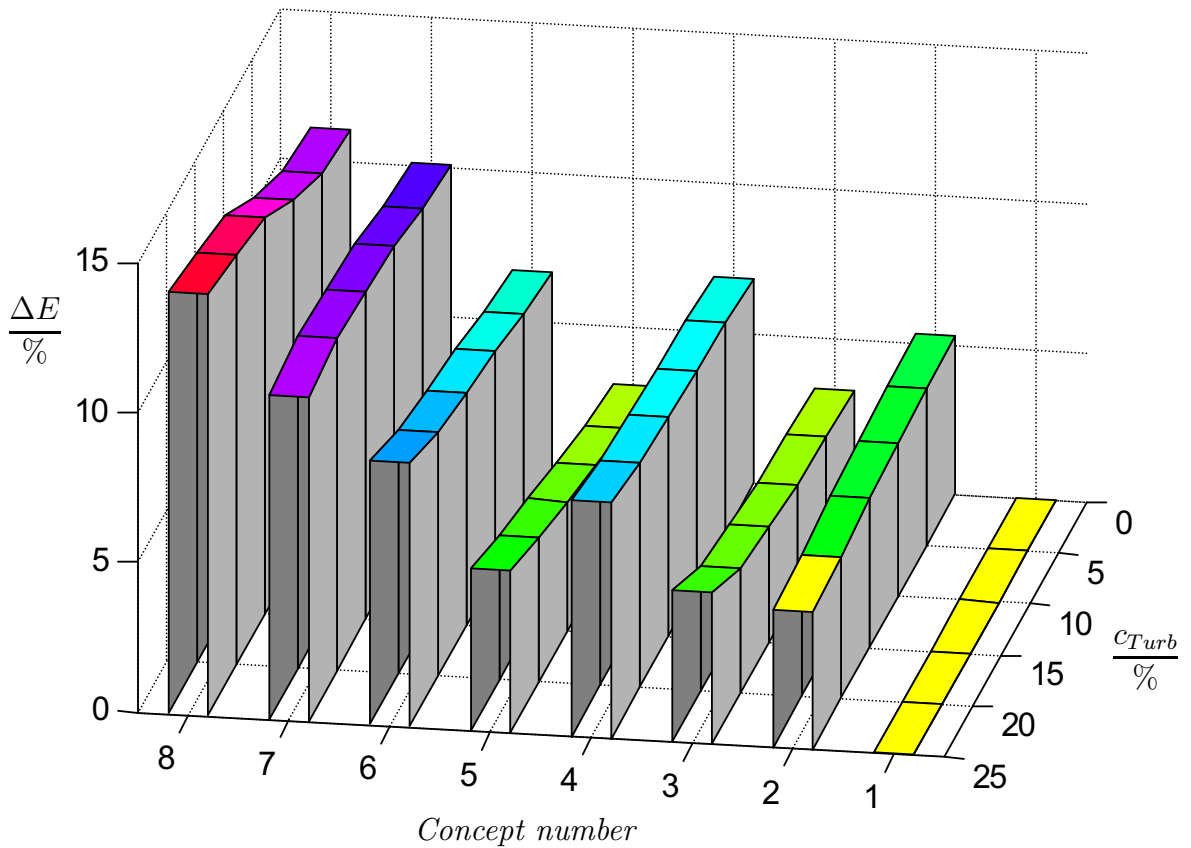

Figure 50: Energy gain of the concepts over concept 1 as a function of c_{Turb} . Parameters: $\bar{v}_{w,a} = 7m/s$, $k = 2$, $\lambda_D = 12$, profile Goe 758.

The next, and surprising difference is that the stall controlled variable speed concept doesn't show the large energy loss which it did for the lower design tip speed ratio. Having the above problem of variable speed concepts in mind, the only explanation can

be that the fixed speed concepts also lose more energy at higher design tip speed ratios and high turbulence. And indeed they do, because their problems are not related to the positive wind gusts, but rather to the negative gusts, where the wind becomes weak and therefore the tip speed ratio leaves the smaller range where good power coefficients are obtained. Also, the “ventilator operation” mentioned in section 5 becomes stronger at high design tip speed ratios.

However, it can be noted that the possibility of the pitch controlled variable speed concept to store some energy in the rotor inertia during wind gusts around rated wind speed (i.e., by running overspeed for some time), still works at higher design tip speed ratios, although the energy gain achieved by this is reduced because the pitch controller has become more dynamic, as was already mentioned. The remaining gain is mainly due to the tolerance band in the speed controller mentioned in section 3.2. The difference between the upper and lower limit of this band also corresponds to a possibility of energy storage, which is used here.

6.6 Influence of the aerodynamic rotor profile

Here, the three different aerodynamic rotor profiles mentioned in section 4.2 will be compared regarding their influence on the relative energy capture of the different concepts. However, it must be noted that as these profiles do not belong to a single systematic line of rotor profiles no conclusions regarding similar profiles can be drawn. Also, it is not clear how realistic the values presented in this section are, because in real wind turbines the aerodynamic profile varies very much between the blade root and the tip, which was not modeled here at all⁵⁹. Therefore, the results in this section should be seen with some mistrust.

However, before discussing the behaviour of the energy gain of the different concepts, it must first be explained why the simulations for these other two profiles were done with a design tip speed ratio of $\lambda_D = 9$ instead of the $\lambda_D = 6$ used for the profile Goe 758. The reason is hidden in the different aerodynamic behaviour mentioned in section 4.2. Due to this different behaviour, the difference between the tip speed ratio where the power coefficient reaches its maximum and the tip speed ratio where stall occurs (i.e. from where on the power coefficient drops very quickly) is much bigger for these two rotor profiles. As the rotor speed of the stall controlled concepts is adjusted to give the correct maximum power, this rotor speed is a function of the aerodynamic behaviour of the rotor. For the two rotor profiles which are under consideration here, it showed up that designing the rotor for a tip speed ratio of $\lambda_D = 6$ lead to unrealistic low rotor speed values (at least for this size of turbines). In order to obtain more realistic values, the design tip speed ratio was increased to $\lambda_D = 9$.

It is also necessary to mention that in the definition used here the design tip speed ratio is the tip speed ratio at which the rotor reaches its highest power coefficient. It is *not* equal to the tip speed ratio at which the wind turbine reaches its highest (=rated) power. The latter of the two is much smaller; for stall controlled turbines, it is the tip speed ratio at which stall occurs on large parts of the rotor.

⁵⁹The reason was that no aerodynamic data would have been available for the intermediate cross sections between the well-defined profiles.

One final word to the stall controlled variable speed concept (7): The following two rotor profiles are not favorable for this concept. Due to their broader rotor characteristic, even with “cutting the edge of the power curve” as described in section 3.2, bringing the rotor into stall leads to excessive torque demands which would make the generator and the power converter very large and expensive (at least the rectifier, if a brake chopper is used). Therefore, the energy gains of this concept are provided here only for completeness and are not interpreted in detail.

First the energy capture of the different profiles as a function of annual mean wind speed will be looked at. Here, figure 51 shows the energy gain of all concepts over the stall controlled single speed concept (1). This figure should be compared to figure 37. At first glance, the two figures look very similar. However, there are some small differences which will be discussed in the following.

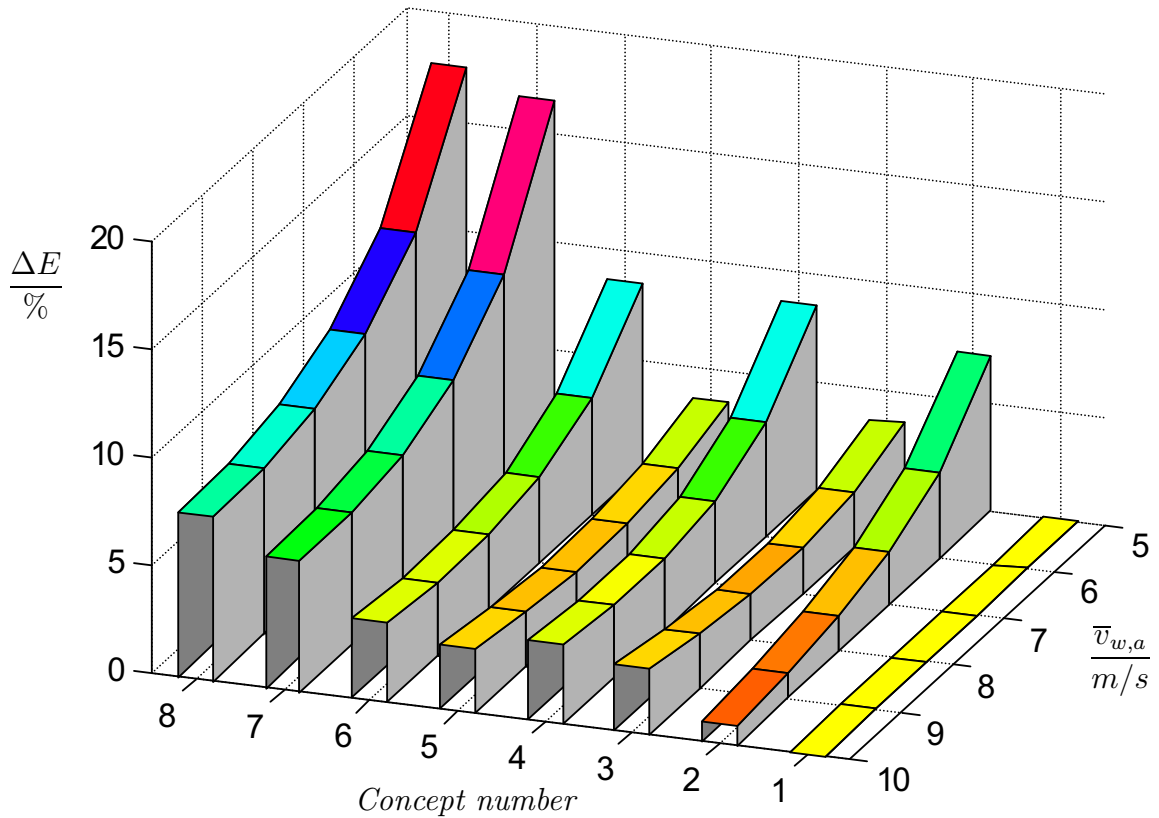

Figure 51: Energy gain of the concepts over concept 1 as a function of $\bar{v}_{w,a}$. Parameters: $k = 2$, $c_{Turb} = 10\%$, $\lambda_D = 9$, profile Goe 771.

The gain for the stall controlled two speed concept (2) is a bit lower in figure 51, especially at low annual mean wind speeds. This is due to above mentioned different rotor behaviour. As with the profile Goe 771 the difference between the tip speed ratio where stall occurs and the optimum tip speed ratio is larger, it is clear that the difference between the same two points in terms of wind speed must have become larger, too. This means that for the same rated wind speed, the wind speed at which

the rotor achieves its highest power coefficient (or aerodynamic efficiency) has become lower. Therefore, the single speed rotor performs better in low wind speeds, which means that there is not as much to win with a two speed concept as in figure 37.

On the other hand, it can be seen that the active stall (3) and pitch (5) controlled single speed concepts gain more than in figure 37. The reason is that the lower wind speed belonging to the maximum power coefficient means that the power curve is more rounded between this wind speed and rated wind speed. As a result, there is more energy to win because also in this area some energy gains are possible by pitching the blades to their optimum angles.

The active stall (4) and pitch (6) controlled two speed concepts are again almost a linear combination of their respective single speed counterparts and the stall controlled two speed concept (2). However, they also have a lower energy gain at low wind speeds due to the better performance of the reference concept (1).

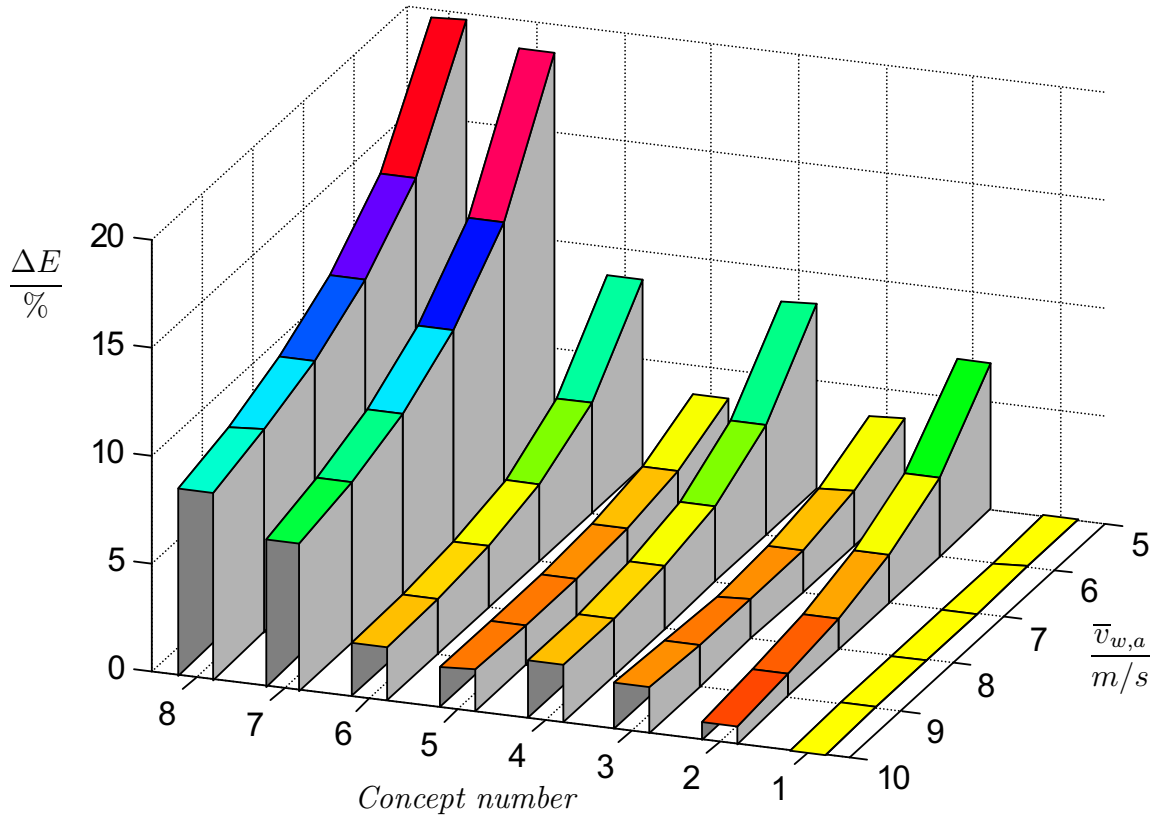

Figure 52: Energy gain of the concepts over concept 1 as a function of $\bar{v}_{w,a}$. Parameters: $k = 2$, $c_{Turb} = 10\%$, $\lambda_D = 9$, profile Goe 535.

After saying this, it is a bit surprising that the variable speed concepts (7) and (8) achieve nearly the same energy gain then in figure 37. The reason is that their low wind speed performance has also improved, for the larger difference between the optimum tip speed ratio and the tip speed ratio at which stall occurs means that following the wind gusts with the rotor speed has become much less critical. Due to the broader

rotor characteristic, no energy will be lost during wind gusts by unwanted stalling.

In figure 52, the same diagram is shown for the rotor profile with the broadest characteristic. As can be seen, it looks very similar to the preceding figure 51.

The only difference is that the energy gain of the variable speed concepts is a bit higher, which is not easy to explain. The fact that the energy gain is increased over the whole range of wind speeds leads to the supposition that the whole form of the power characteristic of the rotor is a bit more favorable for variable speed. However, analyzing this in detail would lead into a completely new field, as it would be necessary to analyze the dependence of the energy gain of all concepts on the form of the power characteristic of the rotor⁶⁰.

Finally, the dependence of the energy gain from the turbulence will be shown for these two rotor profiles, too. Figure 53 shows it for the profile Goe 771. It should be compared to figure 45.

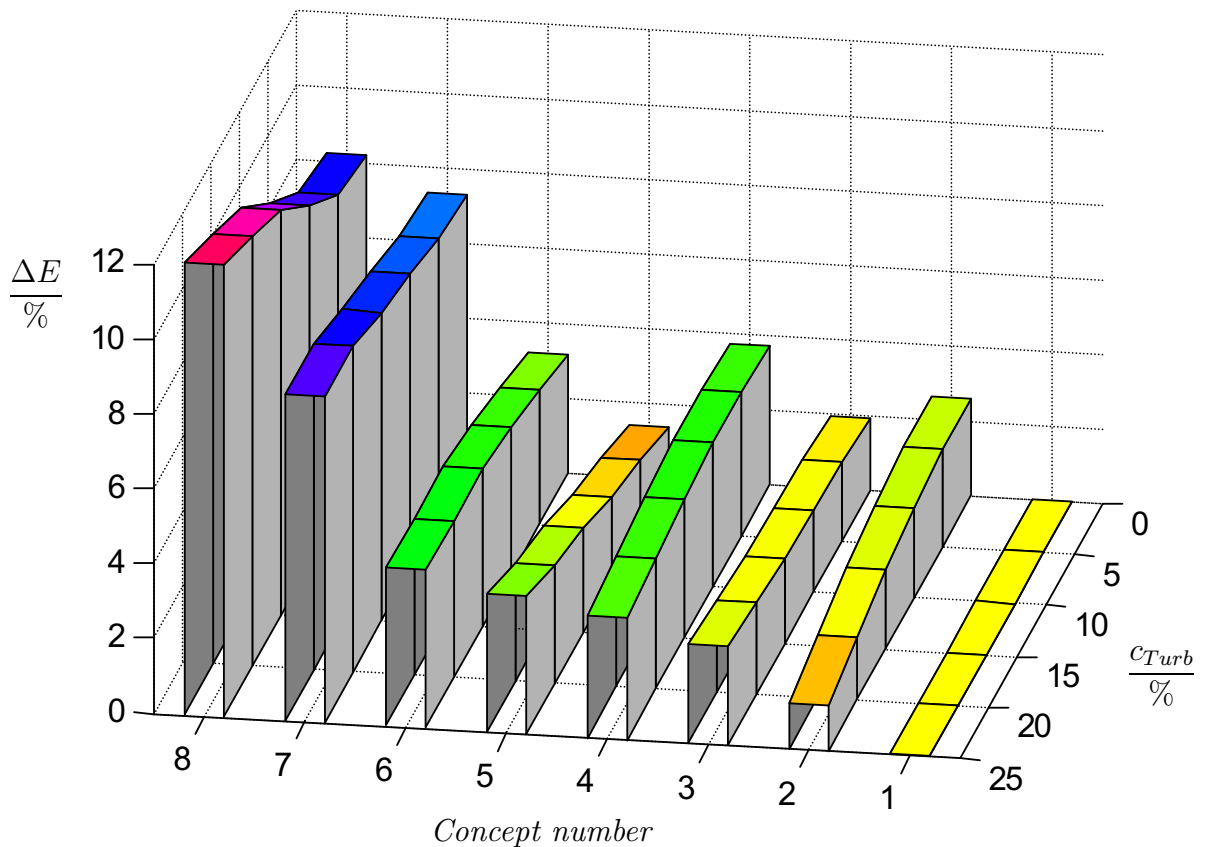

Figure 53: Energy gain of the concepts over concept 1 as a function of c_{Turb} . Parameters: $\bar{v}_{w,a} = 7m/s$, $k = 2$, $\lambda_D = 9$, profile Goe 771.

An interesting point is that the energy gain of the stall controlled two speed concept

⁶⁰Such a study would probably provide a highly interesting subject, especially if it could be broken down to the influence of the profile characteristic. However, the subject of such a study would not be really electrotechnical.

(2) still drops with increasing turbulence, even a bit more than in figure 45. At first glance, one would think that the broader rotor characteristic of this profile would not only decrease the possibility of stalling the rotor during wind gusts in variable speed operation, but also at the lower of the two speeds. However, as a close look shows, this is not true. The reason is the following: At variable speed, the wind turbine tries to operate the rotor at the tip speed ratio which belongs to the maximum power coefficient. If the rotor characteristic is broader (i.e. if the difference in tip speed ratio between this point and the point where stall occurs is larger) then the increase in wind speed which is needed to stall the rotor is also increased. With fixed speed and stall regulation, the rotor speed is adjusted so that the tip speed ratio where stall occurs is at rated wind speed. If the rotor is switched down into low speed operation, the speed where stall occurs is reduced by the same factor than the rotor speed (here by a factor of 2/3). As the low rotor speed is used for the same wind speeds than with the rotor profile Goe 758, this means that the increase in wind speed needed to stall the rotor has *not* increased for the two speed concept.

The active stall controlled two speed concept (3) again shows its good dynamic properties by its energy gain, which is independent of turbulence. Its two speed counterpart (4) again combines this behaviour with the behaviour of the passive stall controlled two speed concept (2), which leads to a slight decrease in energy capture with increasing turbulence. The decrease is slighter than for the concept (2) as the effect of stalling the turbine in low speed operation can be reduced by pitching the blades to the optimum angle for the actual tip speed ratio, which is done by the concept (4).

The increase in energy gain of the pitch controlled single speed concept (5) is smoother than in figure 45. The characteristic of the pitch controlled two speed concept (6) is a combination of the behaviour of the pitch controlled single speed concept (5) and the stall controlled two speed concept (2). Together, this leads to an energy gain which is almost independent of turbulence.

The variable speed concepts (7) and (8) show the improvement of the broader rotor characteristic regarding unwanted stalling during wind gusts at low wind speeds, as the energy gain of the stall controlled variable speed (7) concept is almost independent of turbulence. The pitch controlled variable speed concept (8), however, still benefits from its possibility to store some energy in the rotor inertia during wind gusts around rated wind speed, which can then be used shortly later on, if the wind speed drops below its rated value. This possibility leads to an increase in energy gain with increasing turbulence.

Finally, figure 54 shows the same characteristics for the last rotor profile under consideration, Goe 535.

It can be seen that for this rotor profile with its even broader characteristic most things developed just a bit further than for the last profile, Goe 771. Especially the increase in energy gain of the pitch controlled single speed concept (5) with increasing turbulence has become lower, which means that the dynamic properties of the pitch control are better when using this profile.

This better control dynamics also lead to a reduction of the increase in energy gain with increasing turbulence of the pitch controlled variable speed concept (8), because the better control dynamics mean that the speed controller can limit the power taken from the wind much better during wind gusts. While this certainly reduces the

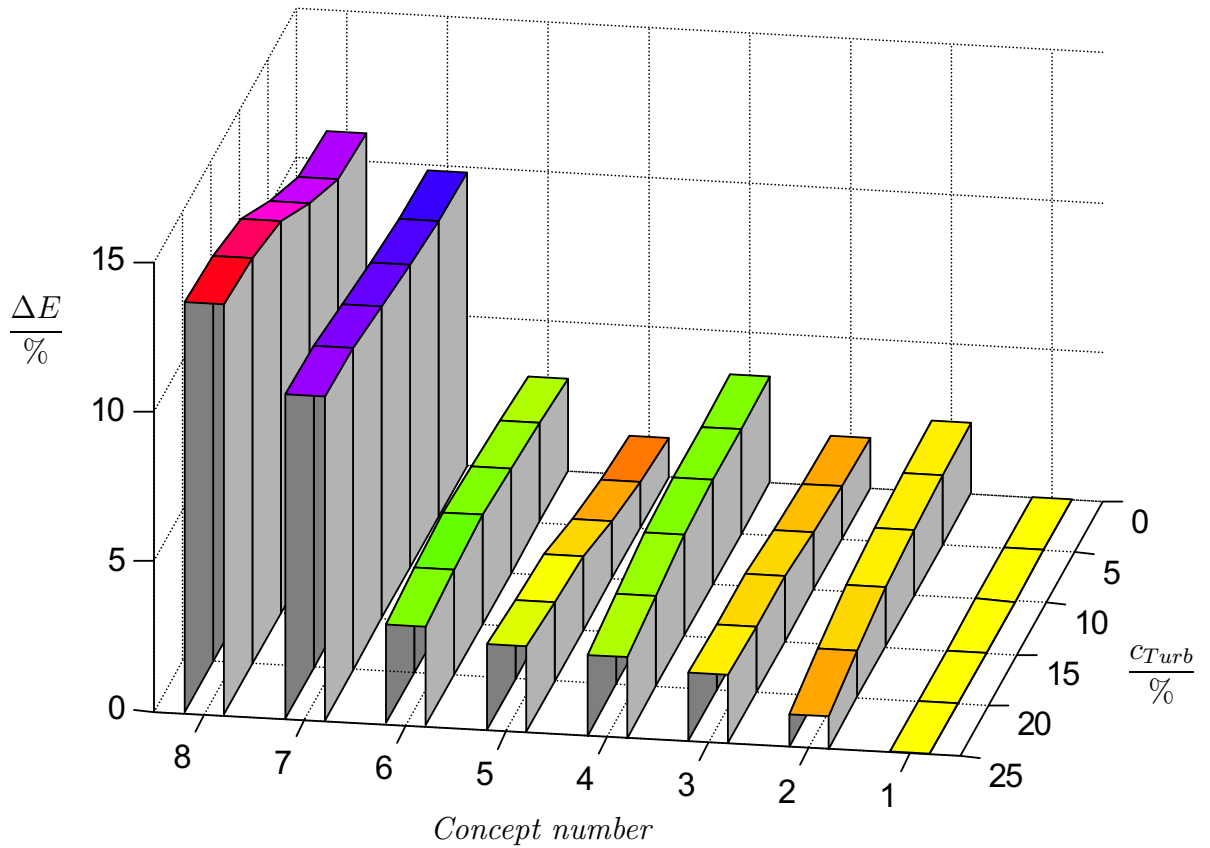

Figure 54: Energy gain of the concepts over concept 1 as a function of c_{Turb} . Parameters: $\bar{v}_{w,a} = 7m/s$, $k = 2$, $\lambda_D = 9$, profile Goe 535.

mechanical stress on components, it also means that the amount of energy which is stored in the rotor inertia during wind gusts around rated wind speed decreases. This of course also means that the capability to bridge short negative gusts has decreased, which leads to the lower increase of energy gain with increasing turbulence so that it approaches the behaviour seen in figure 50. On the other hand, it can be seen that the general energy gain of variable speed concepts has even increased a bit with this rotor profile.

7 Conclusion

This study provides some results concerning the influence of control concepts on the annual energy capture of wind turbines which are equal in the aerodynamic part of the system. As simulations rather tend to overpredict the advantages of complicated systems over simple ones (because the simulations leave out the nonideal behaviour which typically decreases the performance of complicated system more than those of simple systems), these results should be regarded as qualitative rather than quantitative. This is even strengthened by the fact that the modeling used to gain these results has been rather crude.

The results given in this study show that a comparison between the energy capture of the different control concepts is strongly influenced by the site conditions (annual mean wind speed, turbulence and the form of the annual wind speed distribution) as well as by design parameters (design tip speed ratio and choice of rotor profile). The dependence on the parameters is nonlinear so that it doesn't allow any precise predictions for conditions which have not been covered by the simulations.

However, the nonlinearity is not so large that it would be completely impossible to predict general trends, such as the direction in which the gain of one concept over another will develop if a certain parameter is changed. The explanations given for the different phenomena in the discussion of the results may be seen as some hints on what to consider when making such general predictions. This will allow a qualitative extension of the given diagrams to none-given combinations of parameters.

As the parameters of the site conditions can be found in the European Wind Atlas⁶¹ or gained from measurements, this study allows to draw at least general conclusions about the relation between the energy capture of different control concepts. This might be used to get at least general ideas about which concept might suit which place, although the price of the turbine cannot be left out of such a comparison.

Another interesting consequence is that in each comparison a detailed discussion of the parameters used for this comparison is absolutely necessary, as otherwise it is impossible to compare the results of different studies even in a qualitative way.

⁶¹The European Wind Atlas has not been used in this study. Therefore, it is not in the references. However, it is known to be a very valuable source of wind data.

8 Outlook

It is important to understand this study not as one which has produced final results, but rather as a starting point for further investigations. When it comes down to the question in which direction future research efforts may point, the following are regarded as beneficial:

It will be necessary to proceed from a qualitative to a quantitative comparison. This can be done either by measurements, which have the advantage that they do not reflect the reality, they *are* the reality. However, measurements will be expensive and may also be difficult to interpret regarding the agreement reached between the parameters while testing different concepts. Therefore, simulations with more detailed models (especially in the aerodynamic part and the rotor model) would also help a lot. While not possible for this study due to the amount of computation time, they might become possible very soon due to the fast advance of microcomputer technology.

Another interesting topic might be the influence of the rotor characteristic and finally the profile properties on the energy capture, especially if this relation could be inverted somehow so that it would be possible to answer the question what an alteration in the profile characteristic (or the choice of a different aerodynamic profile) will do to the energy capture.

However, the biggest caveat in this study which needs to be closed is that the typical mainstream concept of today, the pitch controlled variable speed wind turbine with gearbox and double fed induction generator is not present. This results from the wrong assessment at the beginning of this study that this concept didn't look very promising. However, now it would mean quite a lot of new simulations, as the efficiency of this concept will be rather different from the same control concept with a direct driven synchronous generator due to the different loss characteristics of the gearbox. Additionally, this concept will also introduce a new parameter, namely the width of the operational speed band, which cannot be neglected for the double fed induction generator, as it is a main design parameter which has an influence not only on the size (and thereby on the price) of the power converter, but also on the annual energy capture.

If a more quantitative comparison of energy capture will become available, it would also be good to have a study on the cost of the different concepts, as a combination of such studies would make it possible to say directly which control concept will be the best choice for which site conditions. Today we are limited to rather general statements, but in a long term view it might become possible to identify the geographic areas where each control concept fits best. So maybe one day we can plot a map of this and tell the future owner of a wind turbine which control concept to choose in order to maximize his economical profit (or to minimize the production costs of wind energy).

9 Appendix

9.1 Derivation of the polynomial coefficients of table 8

In table 8, the formulas for calculating the coefficients $C_{n,2}$ and $C_{n,3}$ are given. However, the derivation of these coefficients is not so simple at first glance. The conditions mentioned in the text near the table – touching the two points $(t_{n-1}, v_{w,n-1})$ and $(t_n, v_{w,n})$ and having horizontal tangents in these points – can be formulated mathematically into the following conditions:

$$v_w(t_{n-1}) = v_{w,n-1} \quad (44)$$

$$\left. \frac{dv_w}{dt} \right|_{t_{n-1}} = 0 \quad (45)$$

$$v_w(t_n) = v_{w,n} \quad (46)$$

$$\left. \frac{dv_w}{dt} \right|_{t_n} = 0 \quad (47)$$

These four conditions can be met with a third-order polynomial, which can be written as

$$v_w(t) = C_{n,0} + C_{n,1} \cdot t + C_{n,2} \cdot t^2 + C_{n,3} \cdot t^3 \quad (48)$$

and its derivative

$$\frac{dv_w}{dt} = C_{n,1} + 2C_{n,2} \cdot t + 3C_{n,3} \cdot t^2 \quad (49)$$

The task is now to determine the four coefficients $C_{n,0...3}$ from the four conditions. Of course this is definitely possible, as inserting the above equations into the conditions gives a linear equation system of fourth order. But solving this system might be a bit lengthy and boring, and it may also lead to lengthy expressions for the four coefficients.

However, things can be simplified much by a simple linear translation of the coordinate system, which is shown in figure 55. The idea behind this translation of the coordinate system is to get one of the two points under consideration into the origin of the translated coordinate system, so that t'_{n-1} and $v'_{w,n-1}$ will become 0. As will be shown, these zeros are sufficient to make the equation system easily solvable.

First, it can be seen from figure 55 that the translation of the coordinate system (and the transformation between the two systems) can be achieved by the following two equations:

$$t' = t - t_{n-1} \quad (50)$$

$$v'_w = v_w - v_{w,n-1} \quad (51)$$

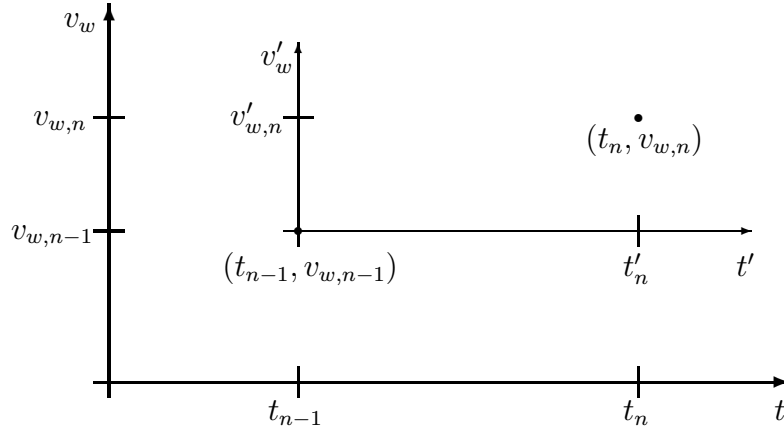

Figure 55: Coordinate transformation for the derivation of the polynomial coefficients

Transforming the four conditions 44–47 gives:

$$v'_w(0') = 0 \quad (52)$$

$$\left. \frac{dv'_w}{dt'} \right|_{0'} = 0 \quad (53)$$

$$v'_w(t'_n) = v'_{w,n} \quad (54)$$

$$\left. \frac{dv'_w}{dt'} \right|_{t'_n} = 0 \quad (55)$$

Inserting the polynomial and its derivative – which are transformed by simply setting t' instead of t , v'_w instead of v_w and $C'_{n,0..3}$ instead of $C_{n,0..3}$ – gives the following four equations for the new coefficients:

$$v'_w(0) = 0 = C'_{n,0} \quad (56)$$

$$\left. \frac{dv'_w}{dt'} \right|_0 = 0 = C'_{n,1} \quad (57)$$

$$v'_w(t'_n) = v'_{w,n} = C'_{n,0} + C'_{n,1} \cdot t'_n + C'_{n,2} \cdot t'^2_n + C'_{n,3} \cdot t'^3_n = C'_{n,2} \cdot t'^2_n + C'_{n,3} \cdot t'^3_n \quad (58)$$

$$\left. \frac{dv'_w}{dt'} \right|_{t'_n} = 0 = C'_{n,1} + 2C'_{n,2} \cdot t'_n + 3C'_{n,3} \cdot t'^2_n = 2C'_{n,2} \cdot t'_n + 3C'_{n,3} \cdot t'^2_n \quad (59)$$

As can be seen, only two equations with two coefficients remain, which can be even more easily solved for the coefficients as the left side of equation 59 is 0. Therefore, first equation 59 is written as (by multiplication with t'_n)

$$C'_{n,2} t'^2_n = -\frac{3}{2} C'_{n,3} t'^3_n \quad (60)$$

which is correct as t'_n must be different from 0 in order to make sense. Now, equation 60 is inserted into equation 58, which gives:

$$v'_{w,n} = -\frac{3}{2}C'_{n,3}t'^3_n + C'_{n,3}t'^3_n = -\frac{1}{2}C'_{n,3}t'^3_n \quad (61)$$

Solving for $C'_{n,3}$ leads to:

$$C'_{n,3} = -2\frac{v'_{w,n}}{t'^3_n} \quad (62)$$

Inserting this in equation 60 gives

$$C'_{n,2}t'^2_n = 3v'_{w,n}, \quad (63)$$

which finally leads to:

$$C'_{n,2} = 3\frac{v'_{w,n}}{t'^2_n} \quad (64)$$

Now, the polynomial can be written as:

$$v'_w(t') = C'_{n,2} \cdot t'^2 + C'_{n,3} \cdot t'^3 \quad (65)$$

Transformed back to the original coordinate system, the result is:

$$v_w(t) = C'_{n,2} \cdot (t - t_{n-1})^2 + C'_{n,3} \cdot (t - t_{n-1})^3 + v_{w,n-1} \quad (66)$$

The equations 62, 64 and 66 are the same as the ones given in table 8, except for the facts that the apostrophes of the coefficients have been left out in the table because there was no need for them there and that the translation was written directly in the equations.

9.2 Parameters of the wind turbine model

The parameters of the wind turbine model will be given in two tables. The first one (table 11) gives the main parameters common to all control concepts, while the second one (table 12) gives the rotor speeds of the single speed and two speed concepts for the different cases. The controller settings of all the controllers are not mentioned for all cases. They can be found out by the procedures used to determine them, which are described in section 4.9.

Table 11: Main wind turbine parameters

Parameter	Value	Dimension
Number of rotor blades	3	
Rated power	600	<i>kW</i>
Rotor diameter	45	<i>m</i>
Rotor inertia	$500 \cdot 10^3$	<i>kgm²</i>

Table 12: Rotor speed for different parameter settings

Profile Goettingen Goe	758			771	535
λ_D	6	9	12	9	9
Rotor speed in s^{-1}	2.42	3.51	4.55	3.08	2.895

9.3 Block diagrams of simulated systems

This section provides block diagrams to illustrate the structure not only of all simulated control concepts, but also of the overall simulation model. Parameters of the controllers can not always be provided, as they are dependent on system parameters such as the design tip speed ratio or the rotor profile under consideration. Examples of these parameters can be found in the tables of sections 3 and 4. There, the procedure used for determining the parameters is also described.

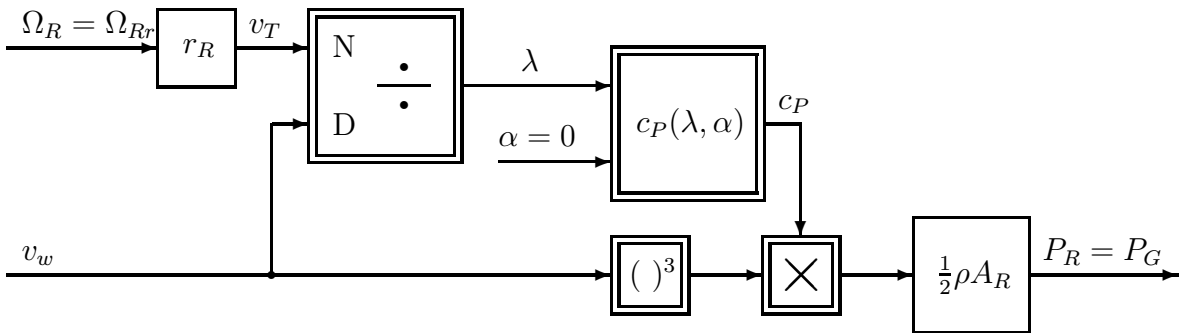

Figure 56: The stall controlled single speed concept.

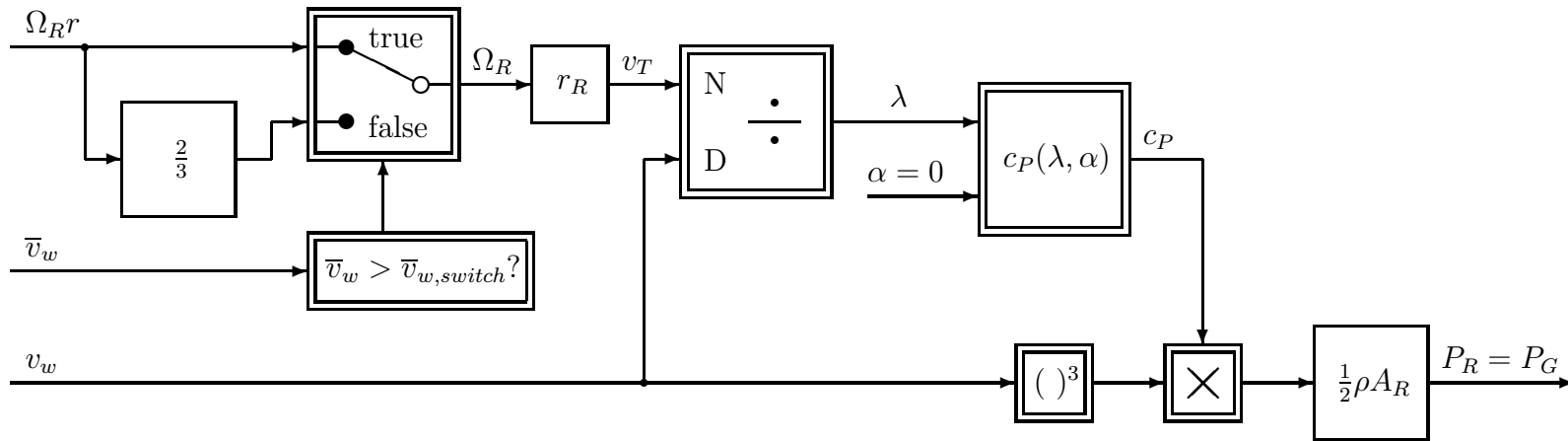

Figure 57: The stall controlled two speed concept. *Note:* The position of the switch determining the rotor speed Ω_R is never changed during a simulation. Its position can only be changed from one simulation to the other.

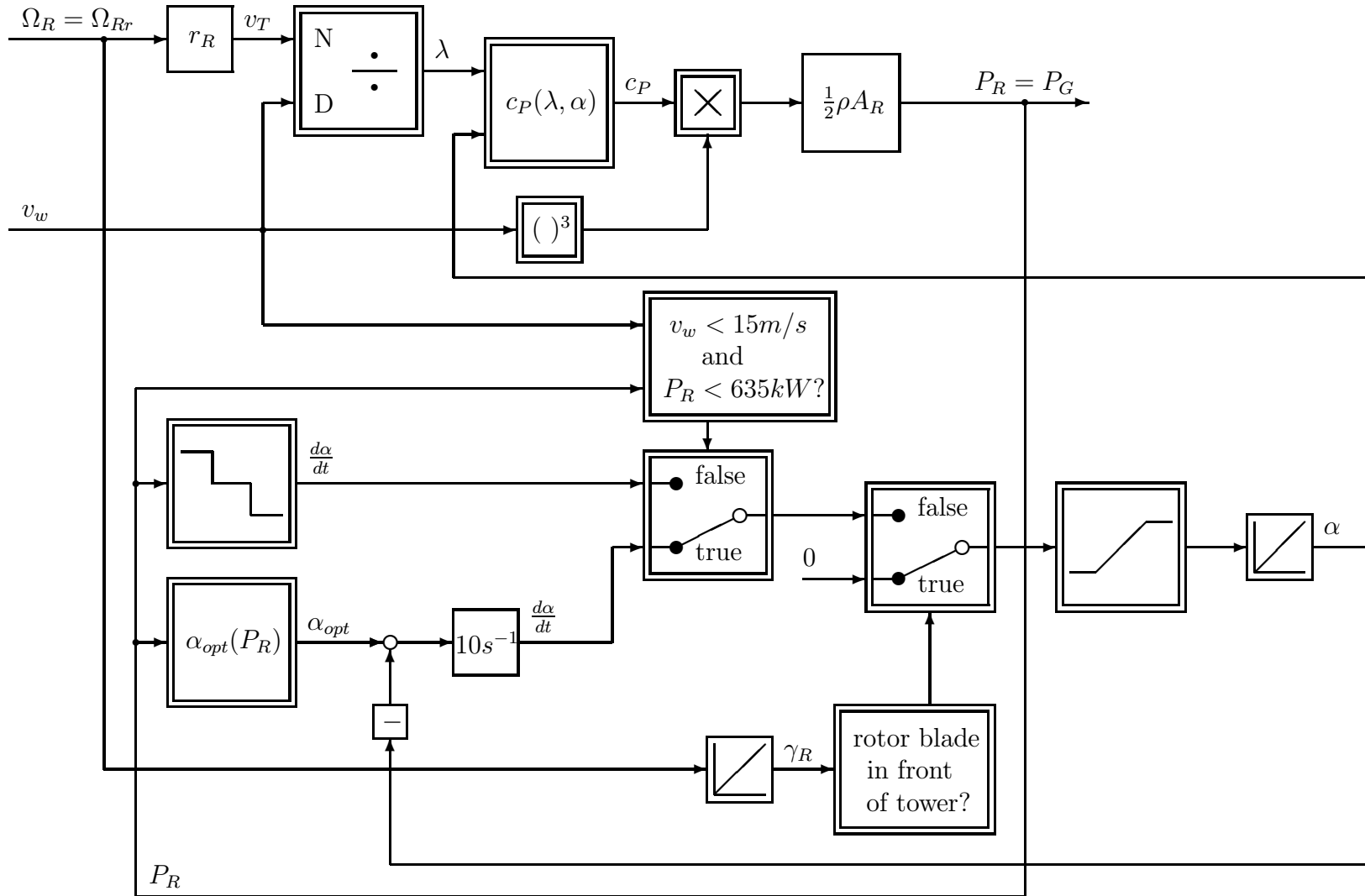

Figure 58: The active stall controlled single speed concept.

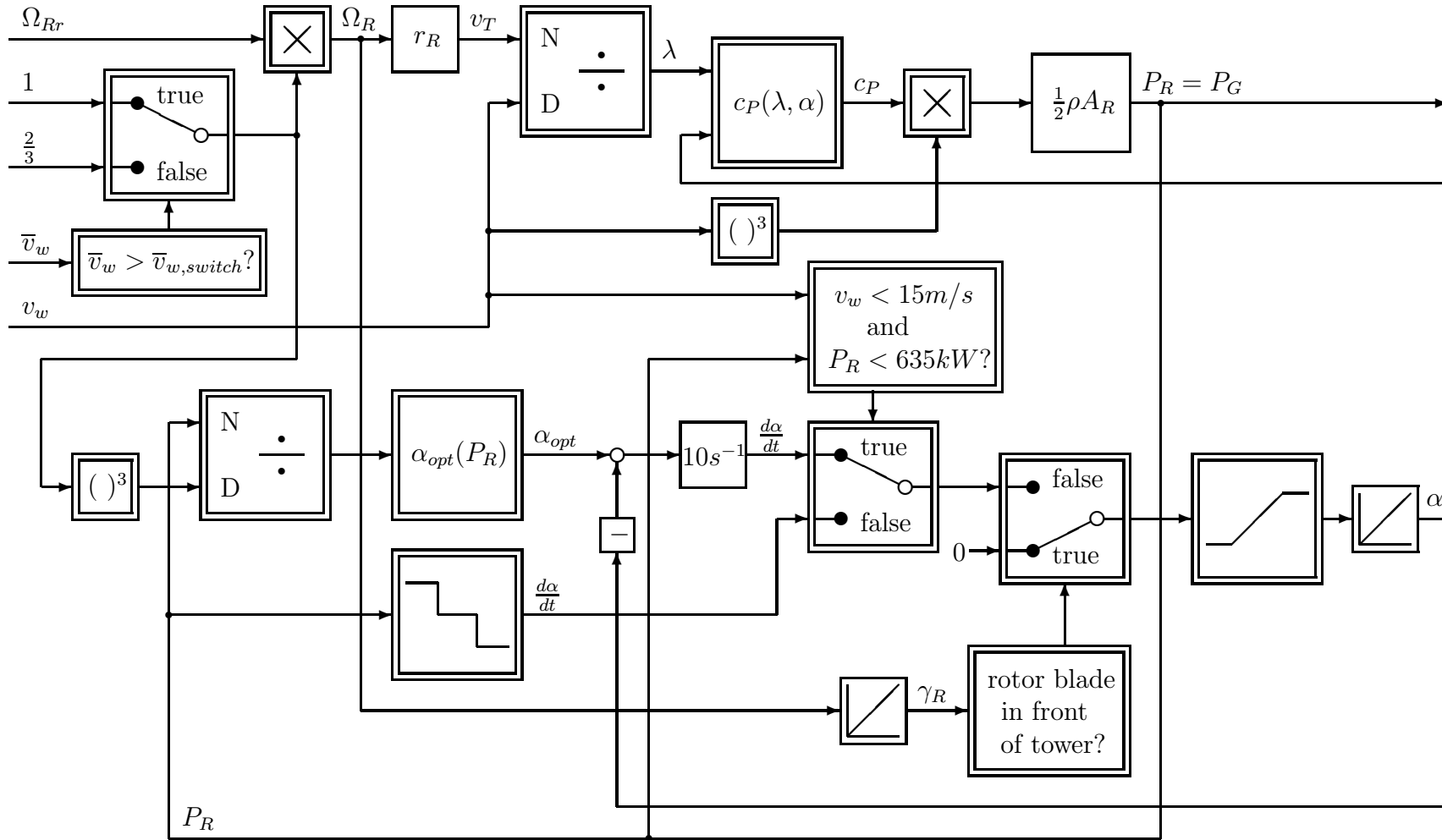

Figure 59: The active stall controlled two speed concept. *Note:* The position of the switch determining the rotor speed Ω_R is never changed during a simulation. Its position can only be changed from one simulation to the other.

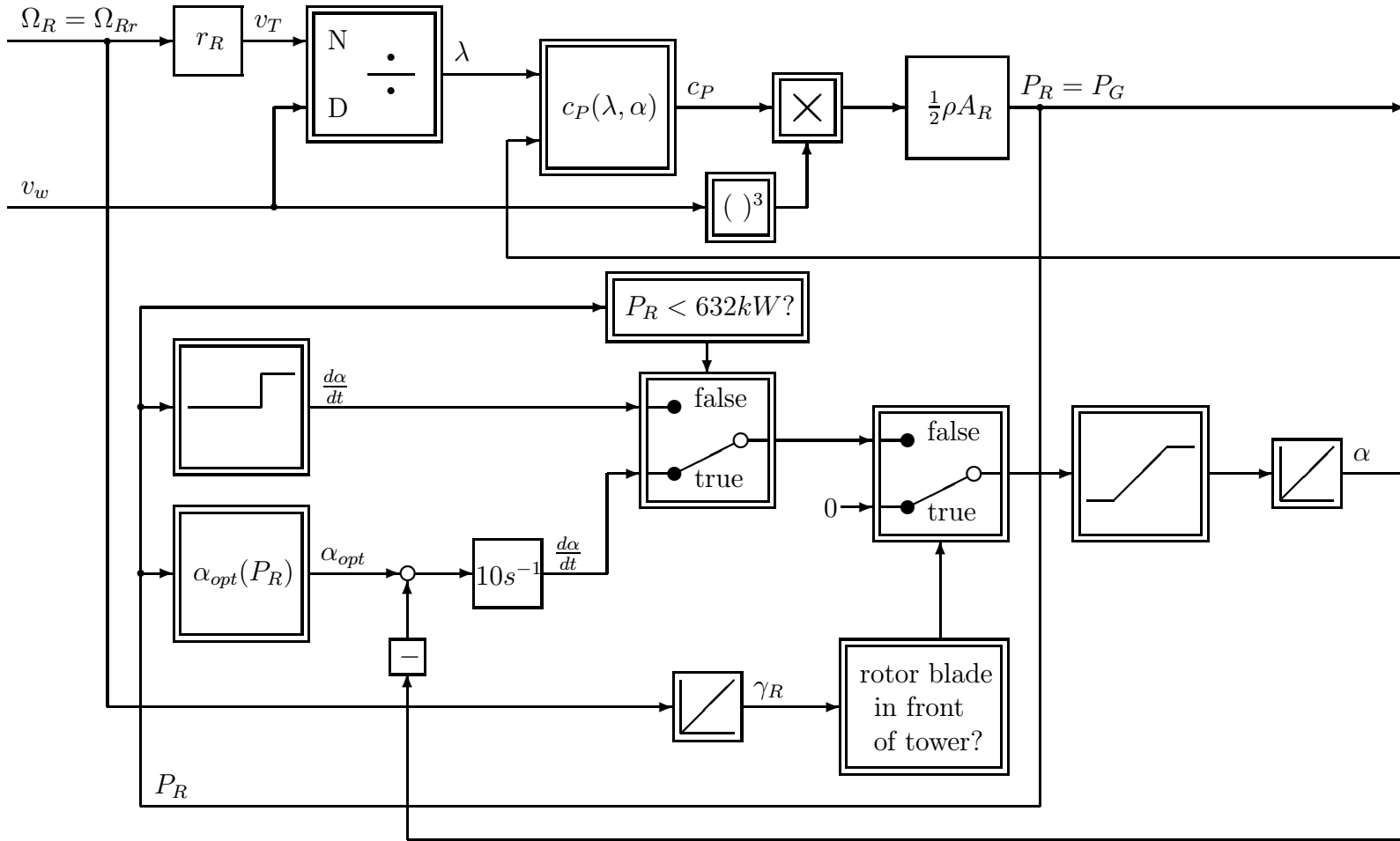

Figure 60: The pitch controlled single speed concept.

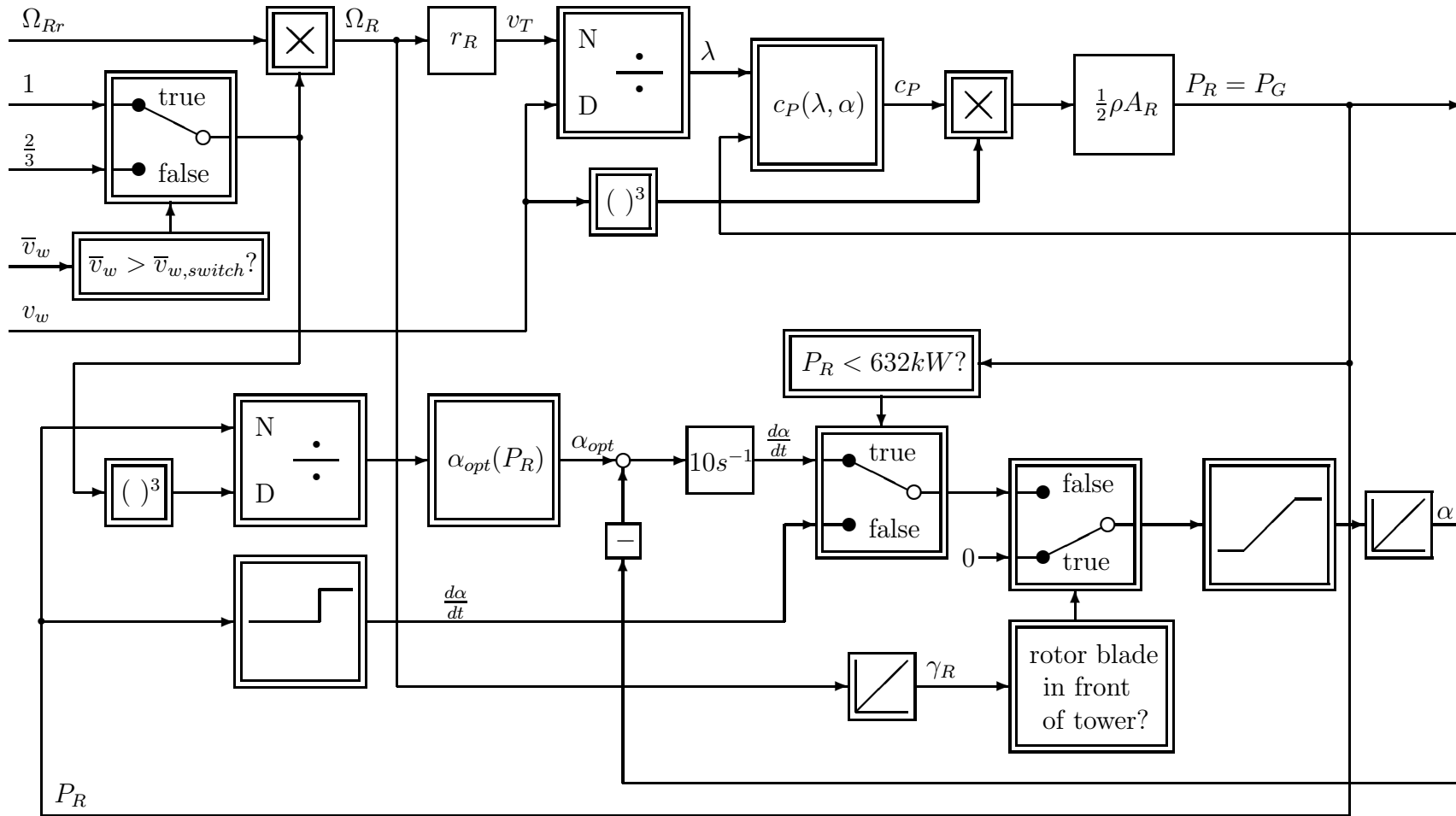

Figure 61: The pitch controlled two speed concept. *Note:* The position of the switch determining the rotor speed Ω_R is never changed during a simulation. Its position can only be changed from one simulation to the other.

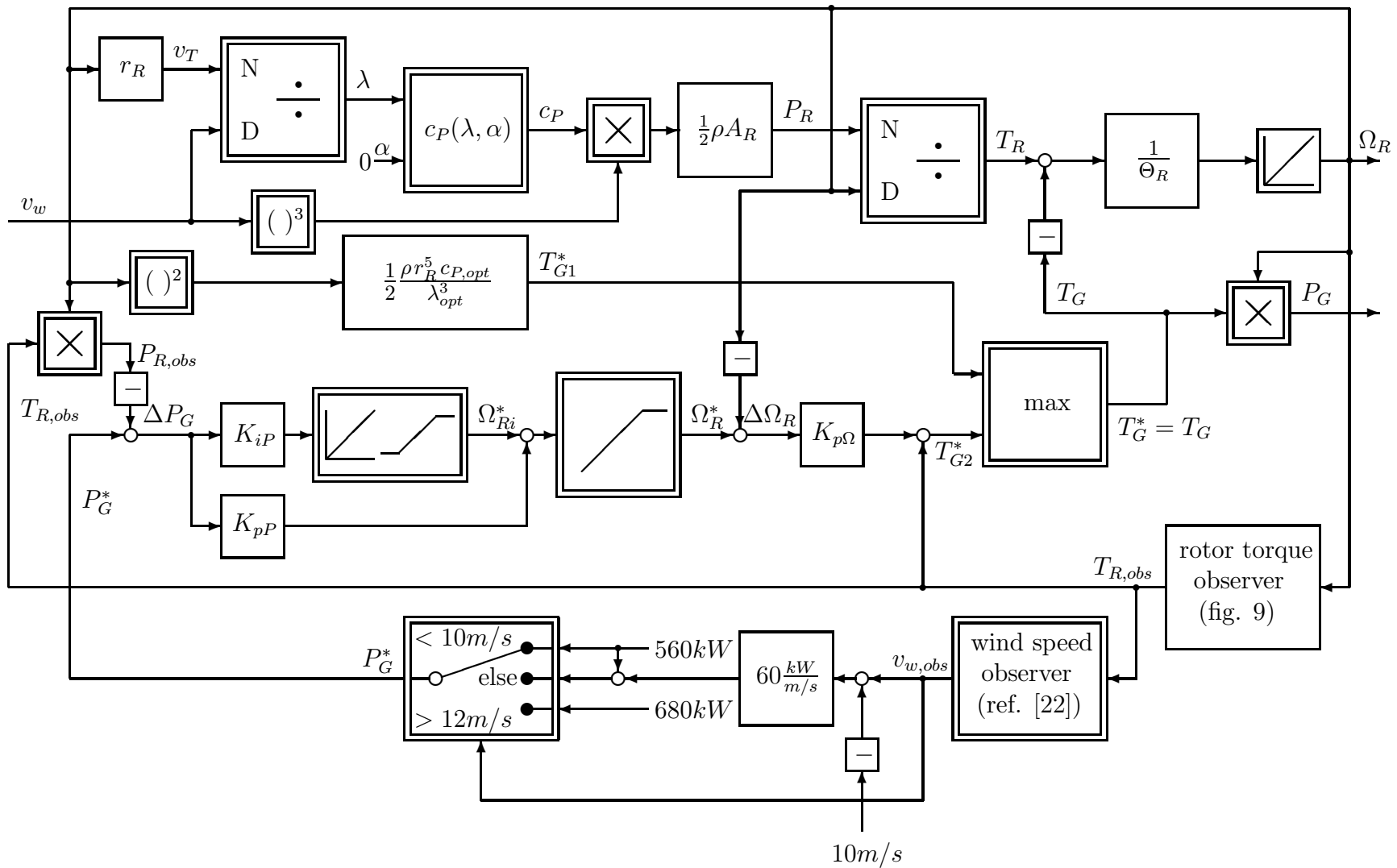

Figure 62: The stall controlled variable speed concept. **Important note:** The wind speed observer has not been used in the simulations! Instead, the actual wind speed v_w was used as observed wind speed $v_{w,obs}$, too, which means that the behaviour of the wind speed observer was assumed to be ideal. The reason for this was to speed up the simulation.

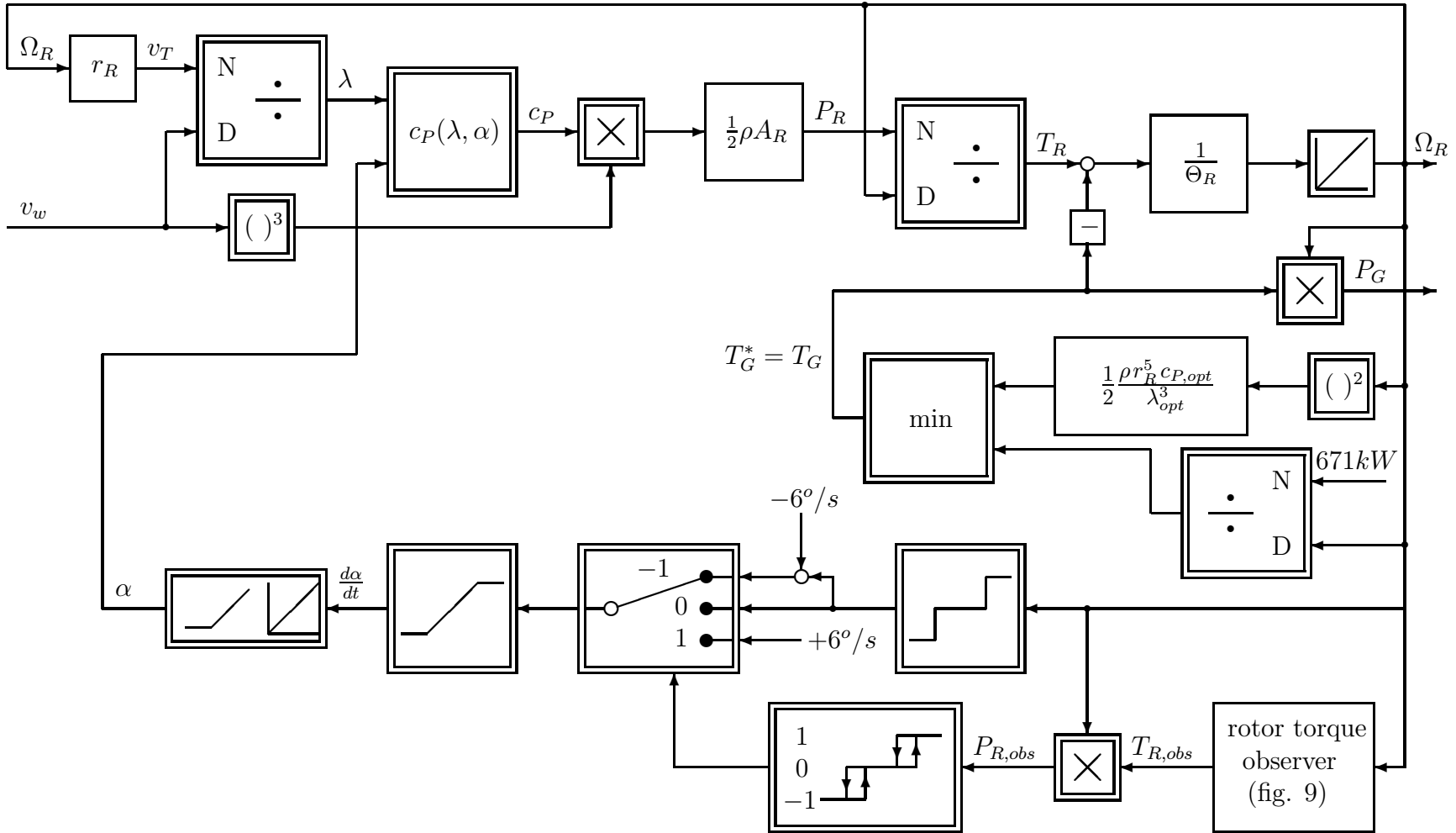

Figure 63: The pitch controlled variable speed concept.

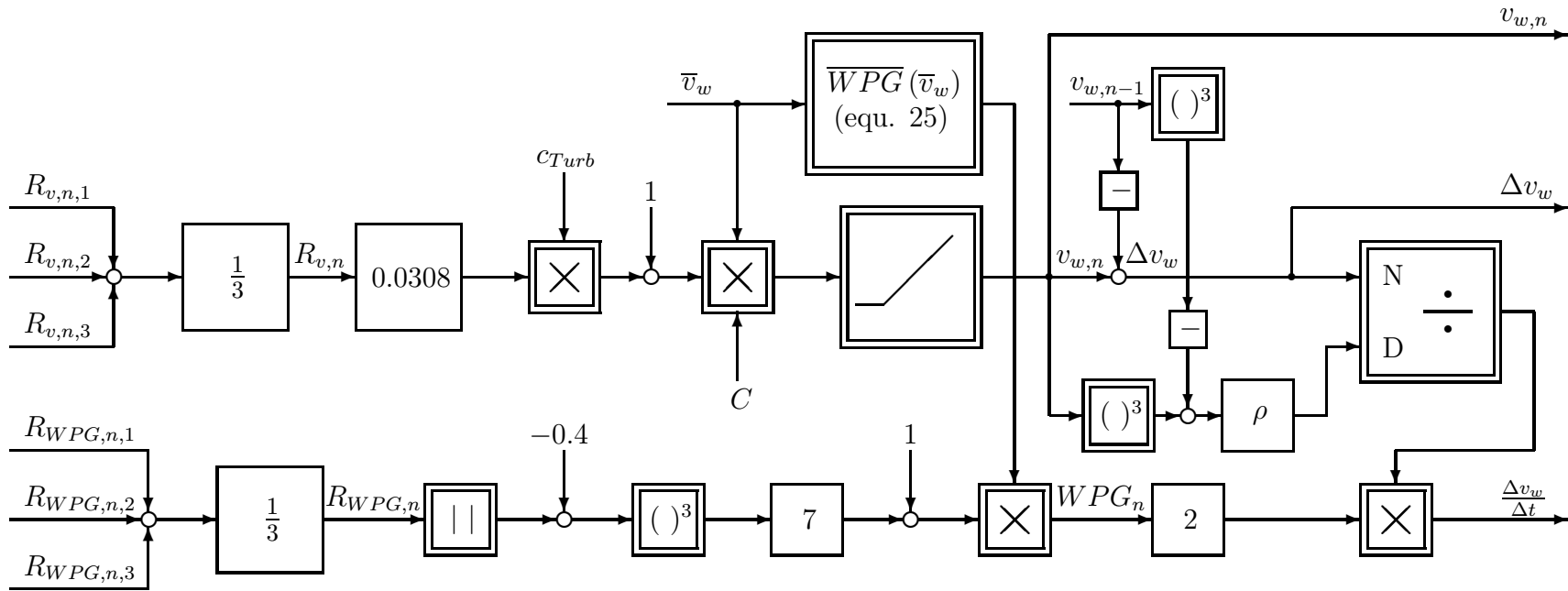

Figure 64: Generation of the polynomial coefficients used for the wind speed generation (part1).

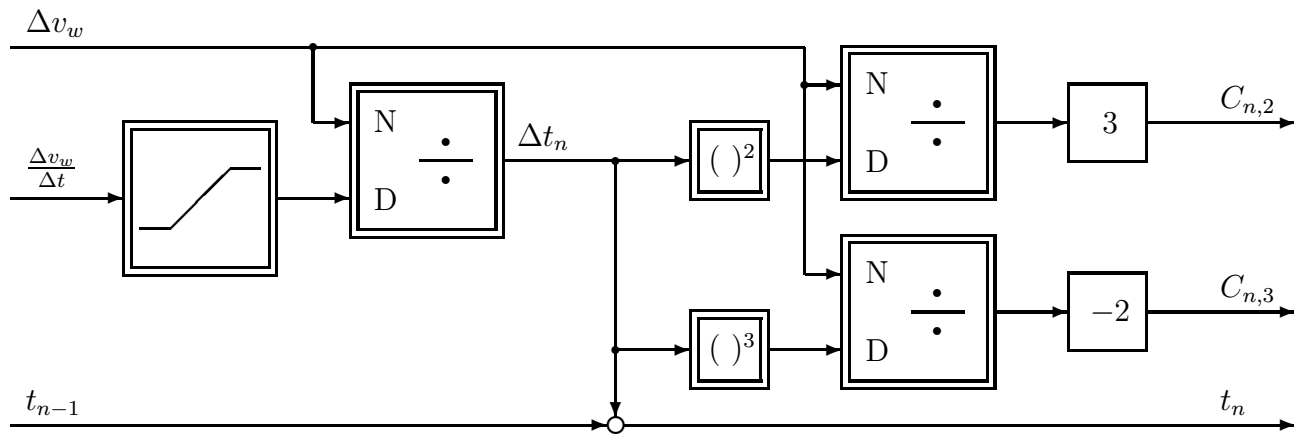

Figure 65: Generation of the polynomial coefficients used for the wind speed generation (part2).

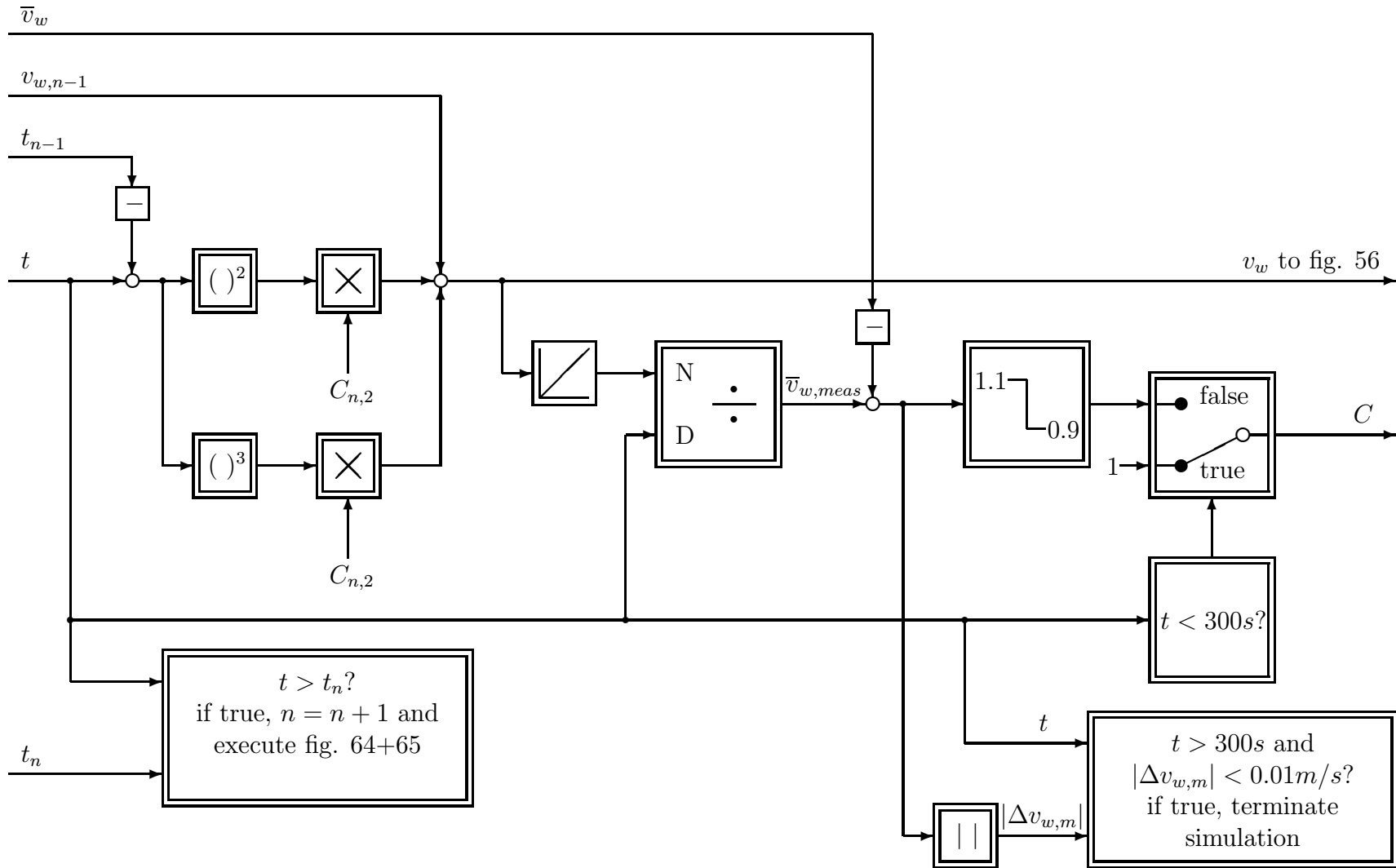

Figure 66: Wind speed generation.

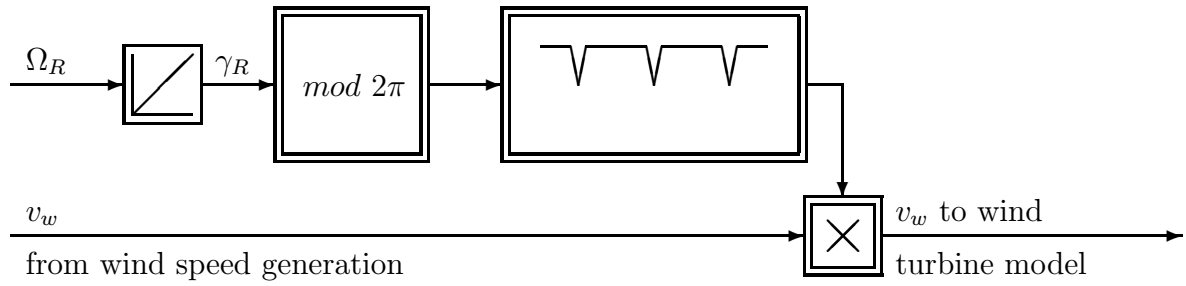

Figure 67: Method used for generating the tower shadow effect, which is needed by the wind speed observer of the stall controlled variable speed concept shown in figure 62. It is used in the simulations to generate some dynamic excitations for the systems.

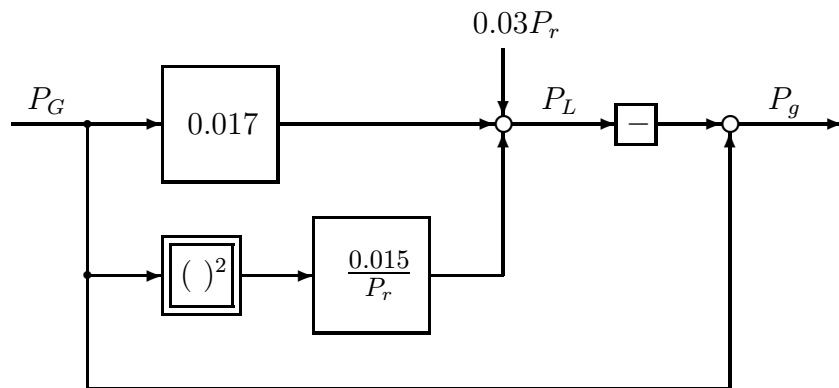

Figure 68: Losses of the single speed and two speed concepts.

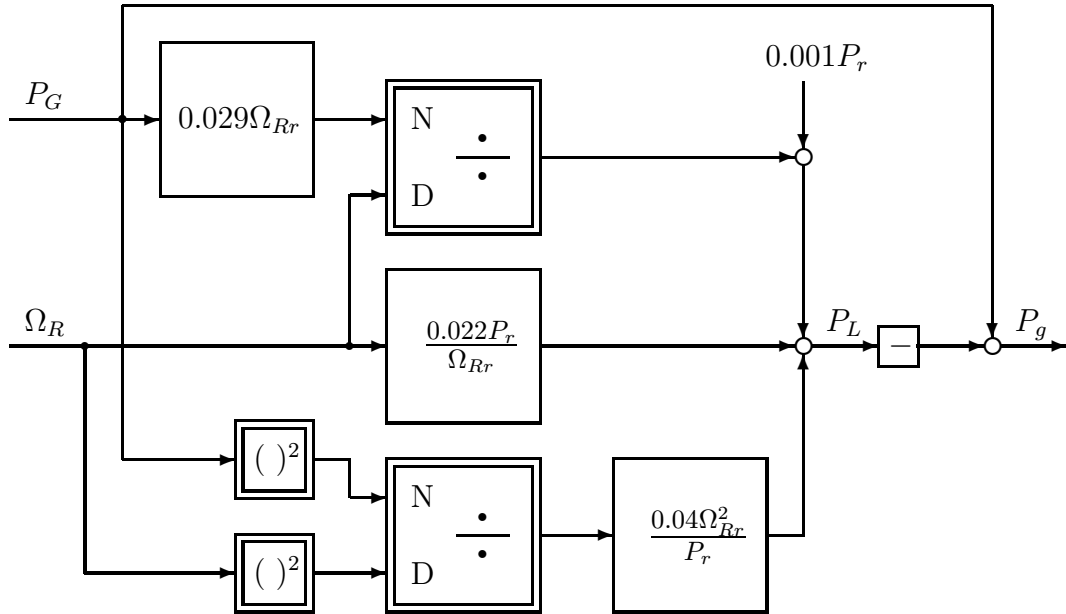

Figure 69: Losses of the variable speed concepts.

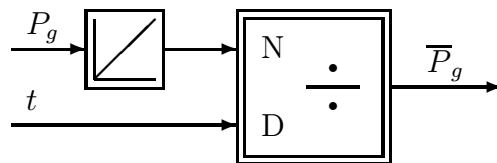

Figure 70: Averaging of the power fed to the grid.

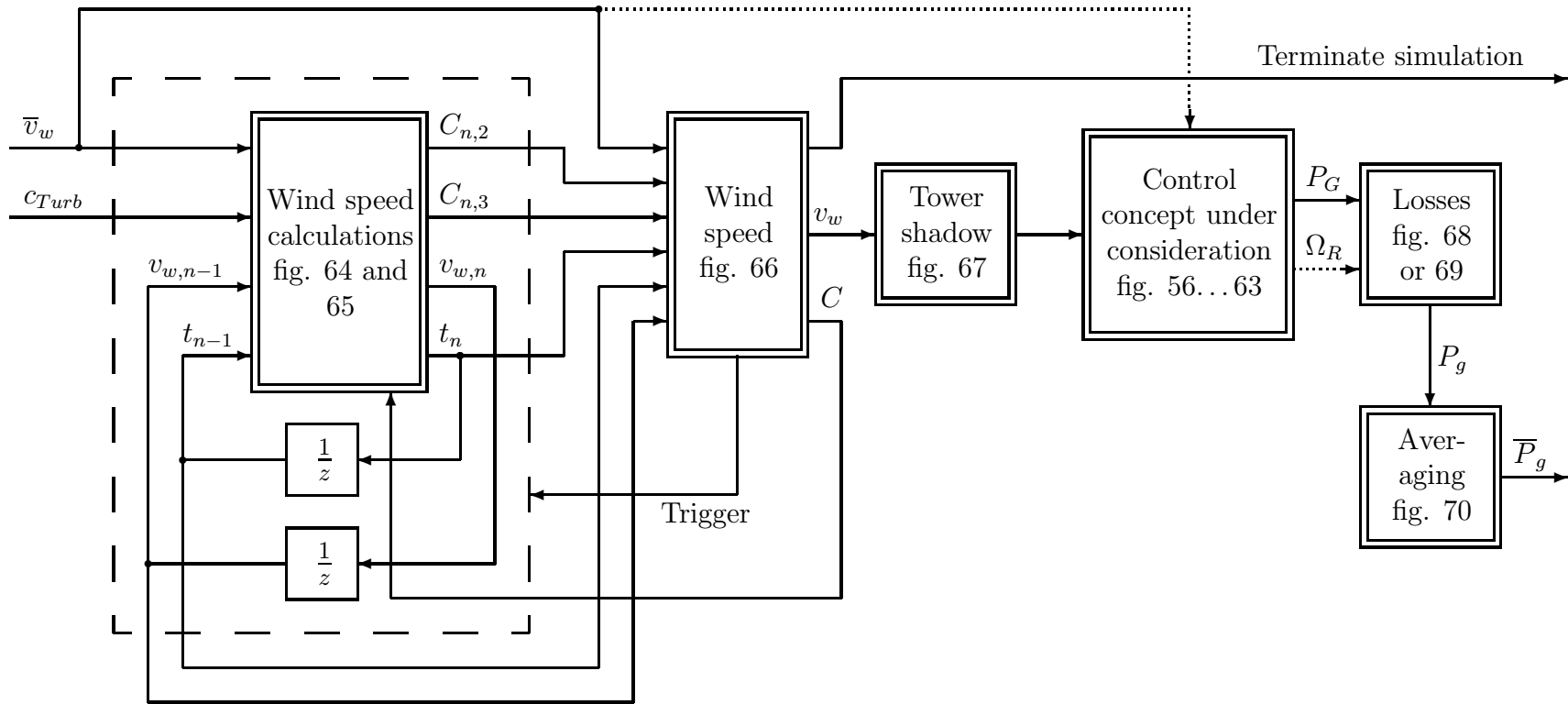

Figure 71: The overall system showing how the different models are interconnected for the simulations.

10 References

- [1] Wolfram Anschütz. *PECSIM – Power Electronics Circuit Simulation, Version F02, Benutzerhandbuch*. Technische Universität Darmstadt, Landgraf-Georg-Strasse 4,D-64283 Darmstadt, Germany, January 1999.
- [2] Wolfram Anschütz. *PECSIM – Version F02, Bedienungshandbuch fuer IBM-RS/6000 mit Betriebssystem AIX*. Technische Universität Darmstadt, Landgraf-Georg-Strasse 4,D-64283 Darmstadt, Germany, January 1999.
- [3] Wolfram Anschütz. *PECSIM – Version F02, Bedienungshandbuch fuer PCs mit WATCOM F77 Compiler*. Technische Universität Darmstadt, Landgraf-Georg-Strasse 4,D-64283 Darmstadt, Germany, January 1999.
- [4] P. Bauer, S. W. H. de Haan, C.R. Meyl, and J. T. G. Pierik. Evaluation of electrical systems for offshore windfarms. In *World Conference on Industrial Applications of Electrical Energy*, pages 1416–1423, Rome, October 2000.
- [5] Henrik Bindner and Anca Hansen. Dobbelt styrbar 3-bladed vindmølle: Sammenligning mellem pitchreguleret vindmølle og pitchreguleret vindmølle med variabelt omløbstal. Risø-Report 1072 (DA), Forskningscenter Risø, Roskilde, Denmark, December 1998.
- [6] Henrik Bindner, Anders Rebsdorf, and Walter Byberg. Experimental investigation of combined variable speed/variable pitch controlled wind turbines. In *European Wind Energy Conference*, Dublin, October 1997.
- [7] A. Björck and S-E Thor. Dynamic stall and 3D effects. In *European Union Wind Energy Conference*, pages 683–686, Goeteborg, Sweden, May 1996.
- [8] G. Böhmeke, R. Boldt, and H. Beneke. Direct drive, geared drive, intermediate solutions – comparison of design features and operating economics. In *European Wind Energy Conference*, pages 664–667, Dublin, October 1997.
- [9] G. Brauner. Netzanbindung von Windkraftanlagen. *e&Ei*, (7/8):428–432, 1999.
- [10] G. Brauner and S. Zapreva. Netzzrückwirkungen von Windkraftanlagen. *e&Ei*, (6):308–313, 1997.
- [11] O. Carlson, J. Hylander, and K. Thorborg. Survey of variable speed operation of wind turbines. In *European Union Wind Energy Conference*, pages 406–409, Goeteborg, Sweden, May 1996.
- [12] John A. Ekaterinaris. Computation of turbulent dynamic stall flowfield. In *European Union Wind Energy Conference*, pages 691–694, Goeteborg, Sweden, May 1996.
- [13] Juergen Ernst-Cathor. *Drehzahlvariable Windenergieanlage mit Gleichstromzwischenkreis-Umrichter und Optimum-suchendem Regler*. PhD thesis, Technische Universtät Carolo-Wilhelmina zu Braunschweig, 1986.

- [14] Bundesverband Windenergie e.V., editor. *Windenergie 2000*. Bundesverband Windenergie, Herrenteichstrasse 1, D-49074 Osnabrueck, 11th edition, 2000.
- [15] Robert Gasch, editor. *Windkraftanlagen*. B.G. Teubner, Stuttgart, 3rd edition, 1996.
- [16] Bengt Gransson and Jan Blix. History and future development of swedish large wind turbine development. In *European Union Wind Energy Conference*, pages 239–242, Goeteborg, Sweden, May 1996.
- [17] A. Grauers. Efficiency of three wind energy generator systems. In *IEEE Transactions on Energy Conversion*, volume 11, pages 650–657, 1996.
- [18] Anders Grauers. Design of direct-driven permanent-magnet generators for wind turbines. Technical Report No. 292, School of Electrical and Computer Engineering, Chalmers University of Technology, Göteborg, Sweden, 1996.
- [19] Kurt S. Hansen, Michael S. Courtney, and Joergen Hoejstrup. Wind data on the world wide web. In *European Wind Energy Conference*, pages 397–401, Dublin, October 1997.
- [20] Erich Hau, editor. *Windkraftanlagen*. Springer Verlag, Berlin Heidelberg, 2nd edition, 1996.
- [21] E.N. Hinrichsen and P.J. Nolan. Dynamics and stability of wind turbine generators. *IEEE Transactions on Power Apparatus and Systems*, (8):2640–2648, August 1982.
- [22] Rolf Hoffmann. Verfahren zur Bestimmung der Windgeschwindigkeit. Disclosure of patent application DE 198 32 207 A 1, 2000.
- [23] Rolf Hoffmann and Peter Mutschler. Energieertragsvergleich von Regelungskonzepten für Windkraftanlagen unter Berücksichtigung der Häufigkeitsverteilung des Windes. In *5. Deutsche Windenergiekonferenz (DEWEK 2000)*, pages 280–283, Wilhelmshaven, Germany, June 2000.
- [24] Rolf Hoffmann and Peter Mutschler. Energieertragsvergleich von Regelungskonzepten für Windkraftanlagen "Welche Regelung passt wann?". *Erneuerbare Energien*, (7):39–41, 2000. Identical with paper presented in Wilhelmshaven.
- [25] Rolf Hoffmann and Peter Mutschler. The influence of control strategies on the energy capture of wind turbines. In *IAS 2000*, volume 11, pages 886–893, Rome, Italy, October 2000.
- [26] M. Idan, D. Lior, and G. Shaviv. A robust controller for a novel variable speed wind turbine transmission. *Journal of Solar Energy Engineering*, 120:247–252, November 1998.
- [27] P. Jamieson and D. C. Quarton. Technology development for offshore. In *European Wind Energy Conference*, pages 289–293, Nice, France, March 1999.

- [28] Theo Kramkowski. Simulation der Leistungskurven und Energieerträge von Windenergieanlagen auf der Basis gemessener Profilgeometrien (simulation of power curves and energy yields of wind turbines on basis of measured profiles of rotorblades). *DEWI Magazin*, (14):38–43, February 1999.
- [29] Søren Krohn. The great california wind rush. Published by The Danish Wind Turbine Manufacturers Association on the Internet:
<http://www.windpower.dk/pictures/windrush.htm>, 1998/2000.
- [30] Søren Krohn. The wind energy pioneer - Poul la Cour. Published by The Danish Wind Turbine Manufacturers Association on the Internet:
<http://www.windpower.dk/pictures/lacour.htm>, 1998/2000.
- [31] Søren Krohn. The wind energy pioneers - 1940-1950. Published by The Danish Wind Turbine Manufacturers Association on the Internet:
<http://www.windpower.dk/pictures/fifties.htm>, 1998/2000.
- [32] Søren Krohn. The wind energy pioneers: The gedser wind turbine. Published by The Danish Wind Turbine Manufacturers Association on the Internet:
<http://www.windpower.dk/pictures/juul.htm>, 1998/2000.
- [33] Søren Krohn. Wind turbines from the 1980s. Published by The Danish Wind Turbine Manufacturers Association on the Internet:
<http://www.windpower.dk/pictures/eighties.htm>, 1998/2000.
- [34] Søren Krohn. Power control of wind turbines. Published by The Danish Wind Turbine Manufacturers Association on the Internet:
<http://www.windpower.dk/tour/wtrb/powerreg.htm>, 1999/2000.
- [35] Joachim Landrath. *Zwischenkreisumrichter für die Regelung einer getriebelosen Windenergieanlage mit permanenterregtem Synchrongenerator*. PhD thesis, Technische Universität Carolo-Wilhelmina zu Braunschweig, 1991.
- [36] A. S. Mercer and E. A. Bossanyi. Stall regulation of variable speed HAWTS. In *European Union Wind Energy Conference*, pages 825–828, Goeteborg, Sweden, May 1996.
- [37] Jens-Peter Molly. *Windenergie*. Verlag C.F. Mueller, Karlsruhe, 2nd edition, 1990.
- [38] F. Mouzakis, G. Bergeles, and N. Athanassiadis. Modelling of dynamic stall effects on the performance of horizontal axis wind generators. In *European Community Wind Energy Conference*, pages 252–257, Herning, Denmark, June 1988.
- [39] P. Mutschler, B. Hagenkort, and S. Joeckel. Control method for variable speed stall-controlled wind turbines. In *European Wind Energy Conference*, pages 542–545, Dublin Castle, Ireland, October 1997.
- [40] N.N. WKA - Technik und Netzanbindung. *etz*, (13-14):38–39, 1996.

- [41] Ion Paraschivoiu and Claude Beguier. Visualization measurements and calculations of dynamic stall for a similar motion of VAWT. In *European Community Wind Energy Conference*, pages 197–201, Herning, Denmark, June 1988.
- [42] Troels Friis Pedersen. Comparison of recommendations for wind turbine power performance measurements. Risø-Report 742 (EN), Forskningscenter Risø, Roskilde, Denmark, December 1993.
- [43] Erik L. Petersen, Niels G. Mortensen, and Lars Landberg. Measurements and modelling in complex terrain. In *European Union Wind Energy Conference*, pages 580–583, Goeteborg, Sweden, May 1996.
- [44] R. I. Rawlinson-Smith. Development of a three dimensional model of dynamic stall. In *European Union Wind Energy Conference*, pages 730–732, Goeteborg, Sweden, May 1996.
- [45] Robert D. Richardson and William L. Erdman. Variable speed wind turbine. European Patent Specification EP 0 569 556 B1, 1992.
- [46] Friedrich Wilhelm Riegels. *Aerodynamische Profile*. R. Oldenbourg, Muenchen, 1958.
- [47] H. Schellhaas. Arbeitsunterlagen zur Vorlesung Mathematik IV fuer ET. Script for lectures, 1993.
- [48] Armin Schöne and Nils Büngener. Ein neuartiges Regelungssystem für Windkraftanlagen. *atp (Automatisierungstechnische Praxis)*, (12):11–20, 1998.
- [49] Constantis Sourkounis. *Windenergiekonverter mit maximaler Energieausbeute am leistungsschwachen Netz*. PhD thesis, Technische Universität Clausthal, 1994.
- [50] C. J. A. Versteegh and T. W. Verbruggen. Development, design and demonstration of NedFlex. In *European Union Wind Energy Conference*, pages 235–238, Goeteborg, Sweden, May 1996.
- [51] Niels Vilsboell, Andrei L. Pinegin, Thorsten Fischer, and Jacob Bugge. Analysis of advantages of the double supply machine with variable rotation speed application in wind energy converters. *DEWI Magazin*, (11):50–65, 1997.
- [52] Klaus Wefelmeier. *Regelung und Betriebsverhalten eines Windenergieparks*. PhD thesis, Technische Universität Carolo-Wilhelmina zu Braunschweig, 1993.
- [53] Donald S. Zinger and Eduard Muljadi. Annualized wind energy improvement using variable speeds. *IEEE Transactions on Industry Applications*, 33(6):1444–1447, November/December 1997.

Curriculum vitae

Rolf Hoffmann

Born:	31 st July, 1970	
Marital status:	unmarried	
School education:	1977-81	Ludwig-Glock-Schule (elementary school) in Messel
	1981-90	Lichtenberg-Gymnasium (grammar school) in Darmstadt
	1990	Abitur
Civil service	1990-91	Diakonisches Werk in Darmstadt
Periods of practical training	1991,1992	Basic practical training at Darmstadt University of Technology and at Adam Ruppel company in Modautal-Asbach
	1994,1995	Advanced practical training at HEAG (local grid utility) in Darmstadt
Study	1991-97	Study of Elektrotechnik, Fachrichtung: Elektrische Energietechnik (Electrical engineering with subject electrical energy engineering) at Darmstadt University of Technology
	1997	Diplom (first degree)
Employment	1997-2001	Scientific employee at the Institute for Power Electronics and Drives of Darmstadt University of Technology
	since 2001	Engineer at Voith Turbo GmbH & Co KG