

Comparison of Wind Turbines Regarding their Energy Generation.

P. Mutschler, *Member, IEEE*,

Department of Power Electronics and Control of Drives
 Darmstadt University of Technology
 Landgraf-Georg-Str. 4
 D-64283 Darmstadt, Germany

R. Hoffmann

Formerly: Department of Power Electronics and Control of Drives
 Darmstadt University of Technology
 Now with
 Voith Turbo GmbH Co. KG

Many different types of wind turbines compete at the market today. One of the major characteristics is, whether a wind turbine operates at a constant or at a variable speed of the wind rotor. To connect a variable speed wind turbine to the grid, always a power electronic converter is necessary. This causes extra investment and additional losses due to the converter. On the other hand, with a converter-fed, variable speed wind turbine, adaptation of the rotor speed to the actual wind speed in order to maximize energy production should be possible. It is important to have an idea, how large the extra energy production of a variable speed wind turbine will be compared to a constant speed turbine in order to decide whether the extra investment will pay off.

However, unfortunately, when looking in recent publications, there is very little agreement on the gain in energy generation of the more sophisticated, variable speed wind turbines over the simple, constant speed turbines. Reference [1] says that variable speed gives an additional energy gain between 2% and 7% over constant speed. In contrast, [2] claims that this gain is up to 20%. Finally, [3] says it is 38%. The difference between these numbers is about one third of the whole energy generation. Therefore, it is clear that there is a high risk for the investor if the gain/price ratio is not known to a higher degree of precision. The aim of this paper is to compare different types of wind turbines concerning their energy production. In this comparison, the dependence of energy production of eight different types of wind turbines on the following parameters is investigated: 1) Average annual wind speed. 2.) Turbulence of the wind. 3.) Design tip speed ratio λ and 4.) Aero-dynamic profile of the blades.

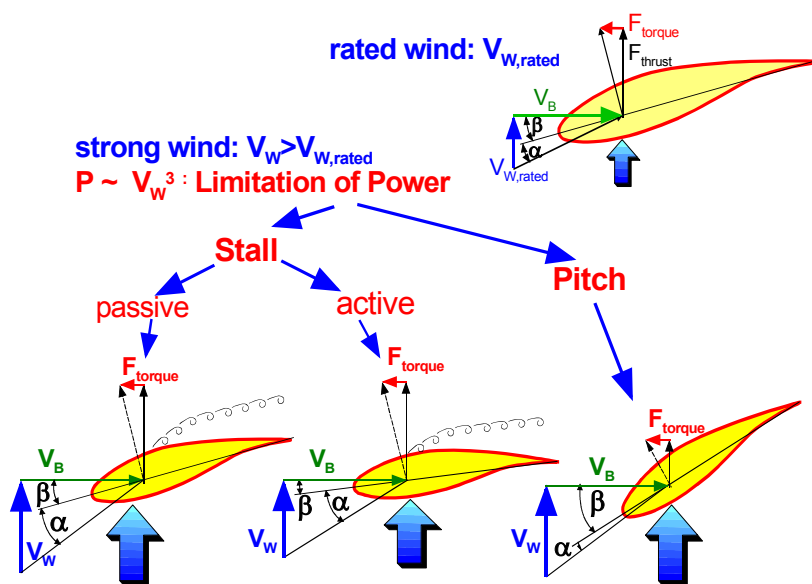

Figure 1: Limitation of power during strong winds

average annual wind speed. 2.) Turbulence of the wind. 3.) Design tip speed ratio λ and 4.) Aero-dynamic profile of the blades.

Types of wind turbines

As many electrical engineers may not be familiar with the conversion of aerodynamic power to mechanical power, in a very brief introduction is shown, how the mechanical torque is produced in a wind turbine. The mechanical power increases with the third power (v^3_{wind}) of the wind speed. During **strong winds**, the power taken from the wind has to be limited to the rated power of the plant using aero dynamical actions

		Speed adaption		
		single speed	two speeds	variable speed
Power limitation	Stall active	1	2	V
	Stall passive	Gear & asynch. generator	Gear & pole changing asynchronous generator	not used
	Pitch	Gear & asynch. generator	Gear & pole changing asynchronous generator	Direct driven synchron. generator & converter

Figure 2: Eight different types of wind turbines are compared.

in order to avoid too high stress on the components. There are two methods to limit the power taken from the wind: Stall and pitch. Stall occurs when the angle α between the air flow and the profile center line (α ="angle of attack") is increased so much that the air flow separates from the surface of the airfoil on the suction side, see Fig.1. It can be done actively by turning the rotor blade to the desired angle ("active stall") or passively by letting the increasing wind speed increase the angle of attack and designing the rotor blade accordingly ("passive stall"). Using the pitch-control to limit the power during strong winds the angle α is greatly reduced, see Fig. 1.

When the **wind is low**, an adaptation of the turbine's speed to the wind- speed has to be considered. In the simplest case, no speed adaptation is implemented. In this classical *single speed* wind turbine a gear and an asynchronous generator is used.

When a pole changing asynchronous generator is used, a limited speed adaptation is realized. Typically, *two speeds* are used in this case.

Full speed adaptation calls for a *variable speed* concept. Here a power electronic converter is always necessary. In our paper, we only consider the gearless, direct driven synchronous generator for a variable speed wind turbine.

The matrix in Fig. 2 shows, that we will compare eight different types of wind turbines, which cover the vast majority of types on the market today.

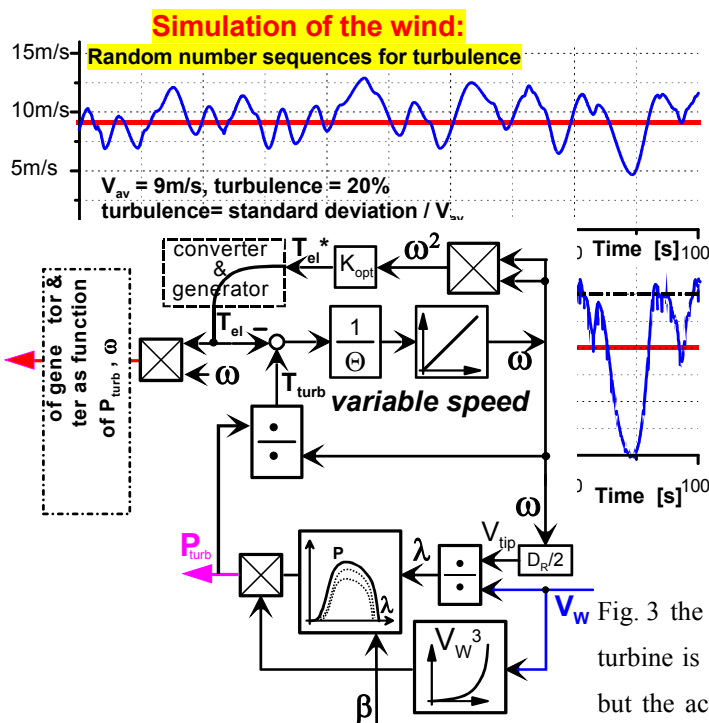

Figure 4: Block diagram of a variable speed, passive stall type of wind turbine

Simulation model.

To compare eight different wind turbines, all must be exposed to identical conditions. With real wind turbines, this would be an extremely expensive approach. Therefore, we use a simulation of the different wind turbines in this paper.

The *simulation of the wind* must contain all average wind speeds and all levels of turbulence which may appear in reality. The upper part of Fig. 3 gives is an example of a wind simulation with an average wind speed of $v_{av}=9m/s$ and a turbulence level of 20%. The turbulence is generated by random numbers and is fitted to practical values of the acceleration of the air. In the lower part of

Fig. 3 the output power of a constant speed, pitch controlled 600kW turbine is shown. With $v_{av}=9m/s$, the average power output is 400kW, but the actual power fluctuates between 700kW and Zero. Instead of feeding a nearly constant power to the grid, the constant speed turbine creates a rather poor power quality.

Component	Loss name	Asynchronous generator (1 or 2 speeds)		Synchronous generator (variable speed)	
		Full load loss in % of P_r	Proportional to	Full load loss in % of P_r	Proportional to
Gearbox	Gear mesh losses	1.7	P		
	No load losses	1.0			
Generator	Copper and additional losses	1.5	I^2	3.5	I^2
	Core losses	1.5		1.2	n
	Friction, windage and cooling losses	0.5		1.0	n
Power Converter	Voltage drop of diodes			0.4	I
	Rectifier resistive losses			0.2	I^2
	Step-up converter transistor losses			0.75	I
	Step-up converter diode losses			0.25	I
	No load losses			0.1	
	Inverter load losses			1.5	I
	Inverter resistive losses			0.3	I^2

(n) is summarized in Table 1.

Simulation and evaluation.

A combination of average wind speed and turbulence is applied to the simulation model and 5 min. of real time are simulated.

The result is the average power that is fed into the grid within these 5 minutes. This power is represented by one of the colored rectangles of the surface in Figure 5. We have to repeat this simulation for

each combination of 23 discrete average wind speeds and 6 turbulences, which gives 138 simulations. As we compare eight different types of wind turbines, we have to repeat

The simulation of the *wind turbine* is based on a quasi steady-state approach. As an example, Figure 4 gives the simplified block diagram of a variable speed, passive stall type of wind turbine. Compared to the time constant of the high inertia wind-rotor, torque transients of the proper controlled converter and generator are very fast. So, their time delay in the upper loop can be neglected. The turbine's characteristic $c_p=f(\lambda,\beta)$ is calculated from a blade element model for several blade profiles. The control is designed to operate the turbine at its maximum power output for wind speeds below the rated one. For wind speeds above the rated one, the control strives for generation of rated power. The losses of the converter and the generator have to be considered carefully, to find the power that is fed into the grid. For all types of wind turbines under comparison, the corresponding simulation models are discussed in the final paper. The calculation of the losses of the different components is based on data taken from literature, mainly from [4]. The dependence of the losses on parameters like power (P), current (I) or speed

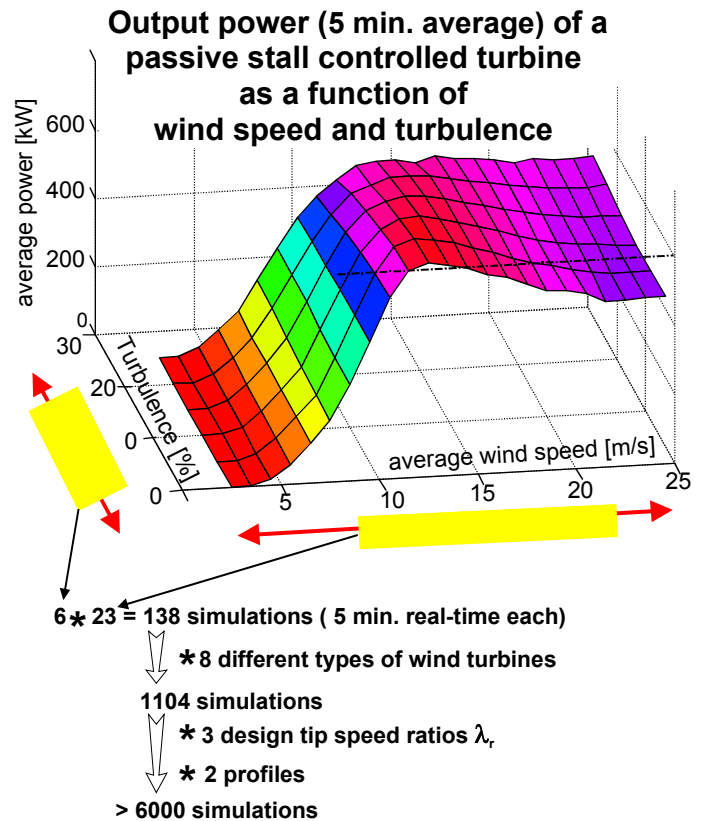

Figure 5: Parameter-space for simulation.

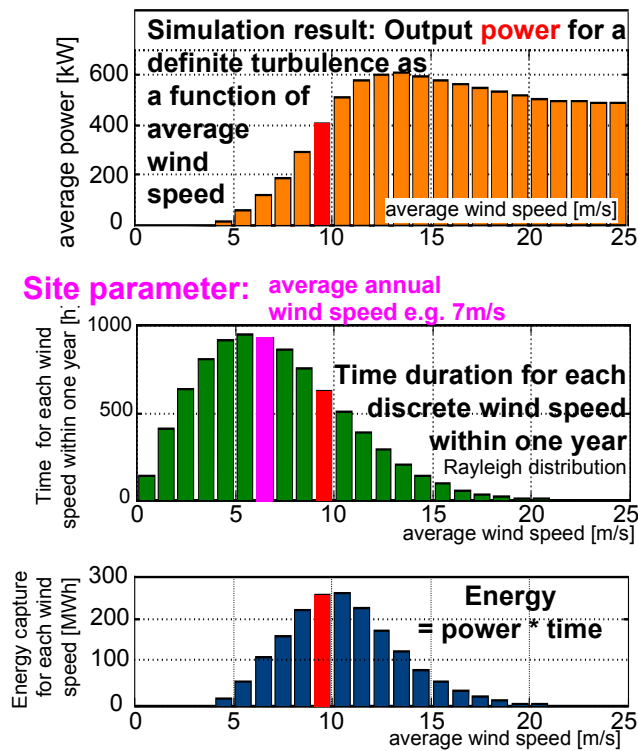

Figure 6: Form power to energy.

the sum of all these energy-bars gives the total energy produced within one year. This is the only number we are interested in.

Discussion of the results.

In Fig. 7, we see the performance of the eight different types of wind turbines, when different average annual wind speeds are applied. In Fig. 7 the following parameters are held constant: Level of turbulence =10%, design tip speed ratio $\lambda_r=6$ and blade profile #1.

First of all we have to note, that the most simple type of wind turbine, which is the single speed, passive stall concept, is used as baseline, i.e. only the percentage of additional energy generation is displayed for the more sophisticated types over the most simple one. The different types of wind turbines are identified by their speed (single, two speed or variable speed) and the method power is limited (stall or pitch).

The message of Fig. 7 is that for a low average annual wind speed, speed adoption of the rotor is interesting. These low wind speeds are typically found at interior sites.

For the two-speed machines, the gain in energy production is 9-11%. The gain of the variable speed machines is 17-18%.

this procedure for each turbine. (-> 1000 simulations) Additionally we want to investigate the influence of some design parameters. We compare 3 different design tip speed ratios λ and 2 different profiles of the blades, which gives a total of >6000 simulations.

For a definite turbulence, we can cut out one slice out of Fig. 5. Then we see the output power as a function of the wind speed for a definite turbulence, as shown in the upper part of Fig. 6.

Wind speed is decisive for energy production at a given site. A wind atlas gives the average annual wind speed and the turbulence for many locations in Germany and other European countries.

In the example of Fig. 6, we have an average annual wind speed of 7m/s. The actual wind at a certain hour within the year may be quite different, of course. In the middle of Fig. 6 we use a Rayleigh distribution, which gives the time duration for each discrete wind speed within one year. The sum of all these time-bars is 8700h.

The energy produced under these conditions is found by multiplying power and time, which is done in lower part of Fig. 6. The

In contrast, for sites with a high average annual wind speed, all turbines are operated at their power limit for a considerably long time in the year. At the limit of power, all deliver a rather similar energy. Therefore, the differences are smaller for high average annual wind speeds. High average annual wind speeds are characteristic for sites near the coast or offshore.

In the final paper, a lot of results obtained by varying different parameters like turbulence, design tip speed or blade profile are discussed and the physical reason of the differences in the performance is explained.

Conclusion

1.) A first result is, that most differences in literature can be explained by different conditions, i.e. the gain in energy generation of the variable speed types of wind turbines compared to the most simple type is in the range of 3% to 28% depending on the site conditions and design parameters. The high gain (28%) was only found when a low average annual wind speed in combination with a high design tip speed was used. But unfortunately, the combination of low average annual wind speed and high design tip speed ratio is probably unrealistic. The low wind speed is characteristic for an interior site. However, the higher acoustic noise due to the high design tip speed ratio may not be tolerated at an interior site. For an offshore site, where the acoustic noise would not be a severe problem, typically the wind is strong. For strong winds however, the gain in energy for all the sophisticated concepts is not so impressive.

2.) More important is the second result:

For a given site, a wind atlas shows the average annual wind speed and the turbulence. These data are inputs to our simulation program. As result of the simulation, we get the energy generation of eight different types of wind turbines. The price for the real wind turbines has to be asked from the manufacturers. Then the price to energy ratio is known, which is a rather important criterion for a final decision.

An additional aspect for a final decision is “power quality”. Variable speed turbines typically provide better power quality, as energy from wind gusts can partially be stored in the rotating mass. However, it is difficult to measure the improved power quality in terms of money.

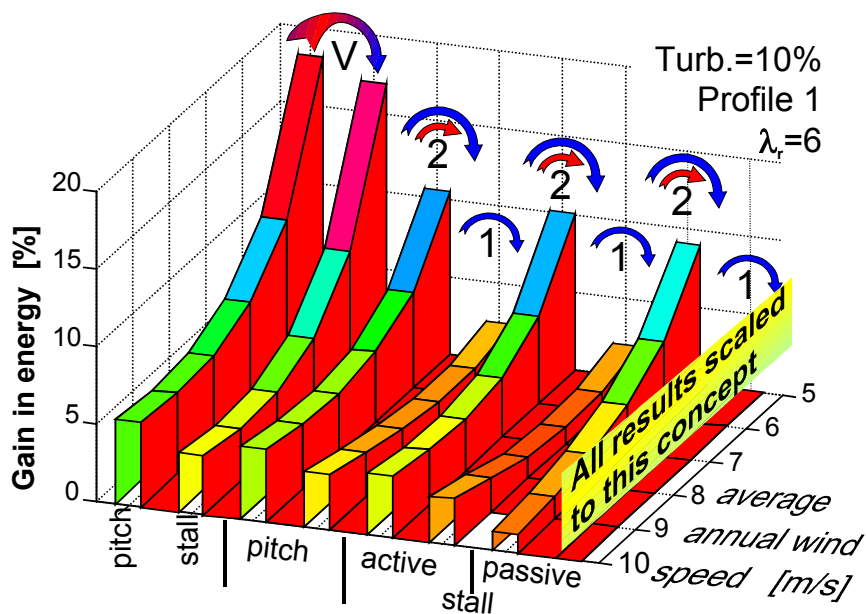

Figure 7: Comparison of energy production when only the average annual wind speed is varied.